



citynox

L'INOX DANS TOUS SES ETATS!



citynox
Révéler les possibles de l'inox
www.citynox.fr



SOMMAIRE

➤ BORNES 6-13

Bornes Toscane	7
Bornes Andria	8
Options bornes	9
Ancrage & normes	10
Bornes amovibles	
Toscane et Andria par clé triangle	11
Toscane et Andria par clé ergot	12

➤ ARCEAUX VÉLOS 14-19

Andria	15
Éole	16
Noréa	17
Toscane	18
Multi	19

➤ CLOUS 20-23

Clous urbains	21
Clous podotactiles	22-23

➤ CENDRIER 24

➤ CORBEILLE 25

➤ LES AUTRES PRODUITS 26-29



UN SAVOIR-FAIRE UNIQUE DANS LA TRANSFORMATION DE L'INOX

- Une large gamme de produits,
- Un service de R&D et un bureau d'études intégré,
- Une capacité de production en petites, moyennes et grandes séries,
- Un outil de production industriel utilisant des technologies de pointe,
- Un atelier blanc dédié à la transformation de l'inox,
- Des procédés uniques et innovants brevetés permettant une qualité de finition inégalée,
- Un savoir-faire dans le travail des métaux nobles transmis depuis 4 générations.

UN INTERLOCUTEUR DÉDIÉ QUI VOUS ACCOMPAGNE



UN SERVICE COMMERCIAL RÉACTIF
Devis 24h Chrono.



UN SERVICE LOGISTIQUE
Suivi en temps réel de vos commandes.



Un site de production alliant rapidité et qualité. Les machines à la pointe de la technologie comprennent: une découpe laser haute performance (vitesse 500 mm / seconde), une presse plieuse numérique 6 axes, un centre de pliage automatisé, une cintreuse CNC à 9 axes ...



CHIFFRES CLÉS

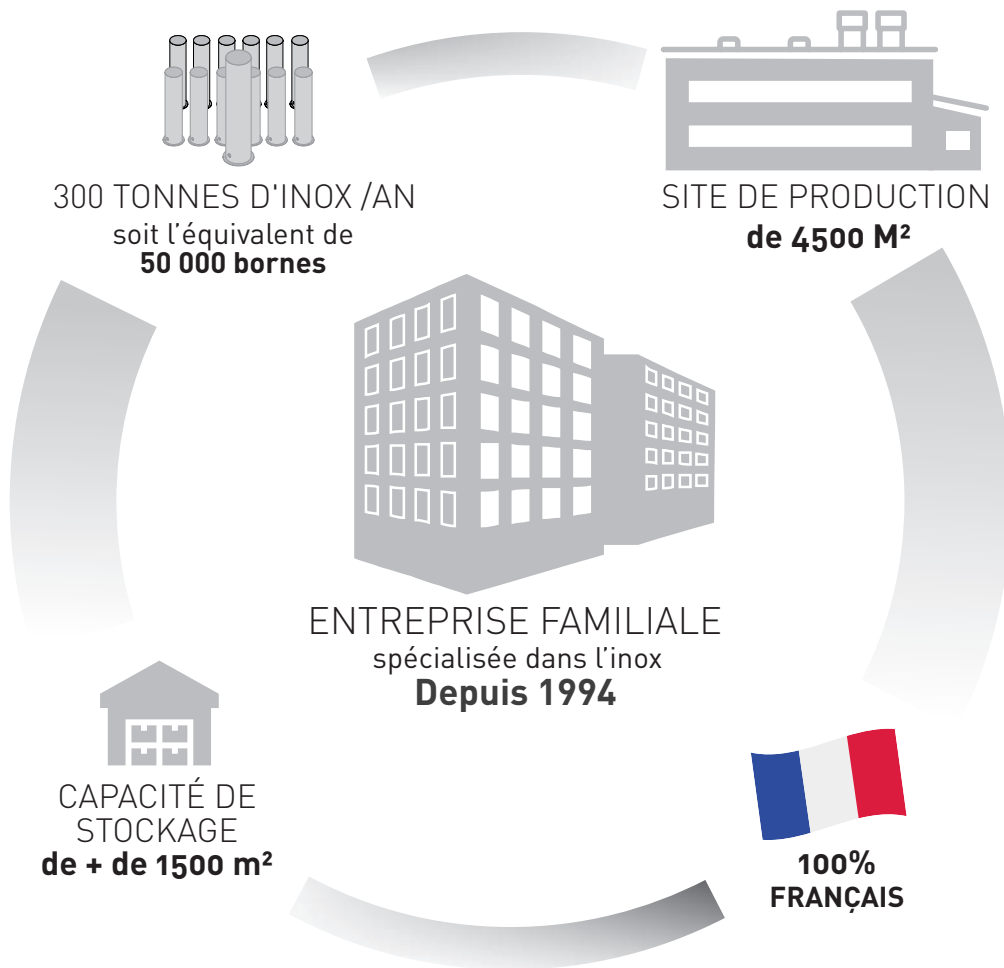

INOX, ESTHÉTISME ET DURABILITÉ

Par ses qualités, l'inox permet de répondre aux demandes les plus variées d'équipements, de mobilier urbain ou encore d'aménagement d'espaces :

DURABILITÉ

il offre une résistance remarquable au temps et à la corrosion ;

ESTHÉTISME

inox brossé, microbillé, poli-miroir, poli-brillant, peint... ;
les finitions possibles permettent de satisfaire les exigences
les plus élevées en matière de design ;

POSSIBILITÉS DE PERSONNALISATION INFINIES

nos limites sont celles de votre créativité ;

FAIBLE IMPACT ENVIRONNEMENTAL

recyclable à l'infini, l'inox est un alliage neutre et stable vis-à-vis de l'environnement.

BORNES



BORNES

TOSCANE

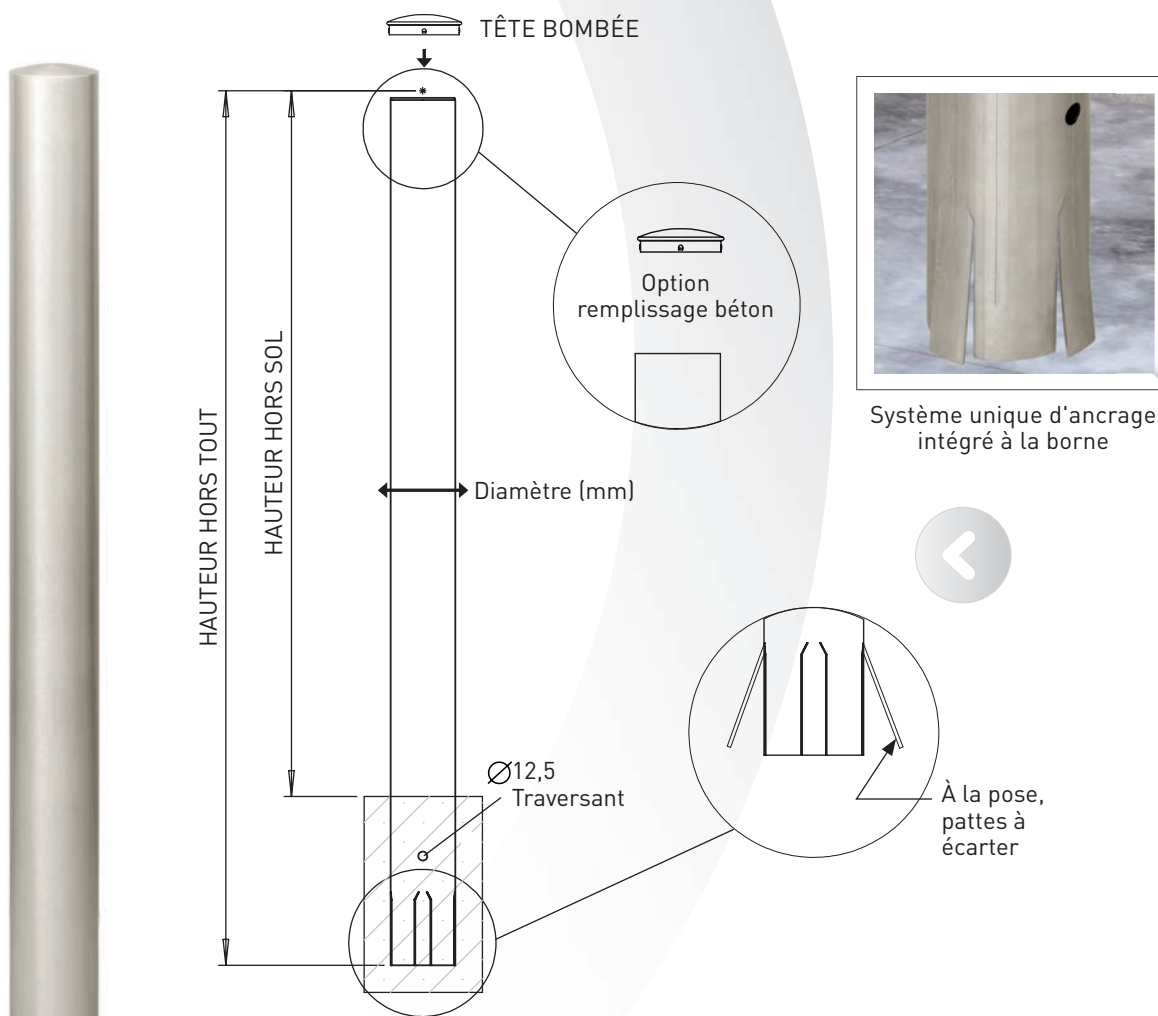

Système unique d'ancrage intégré à la borne

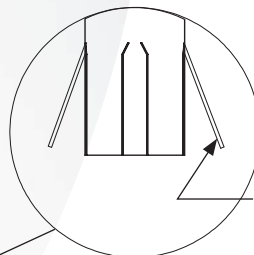

À la pose, pattes à écarter



FIXATIONS

À sceller ou sur platine



MATIÈRE

304 - 316



DIAMÈTRES

60.3 | 76.1 | 88.9
104 | 114.3 | 139.7
154 | 204 | 219 | 254



HAUTEURS

HORS SOL	HORS TOUT
500	750
750	1000
1000	1200
1200	1500



OPTION

Détail en page 9

BORNES

> ANDRIA

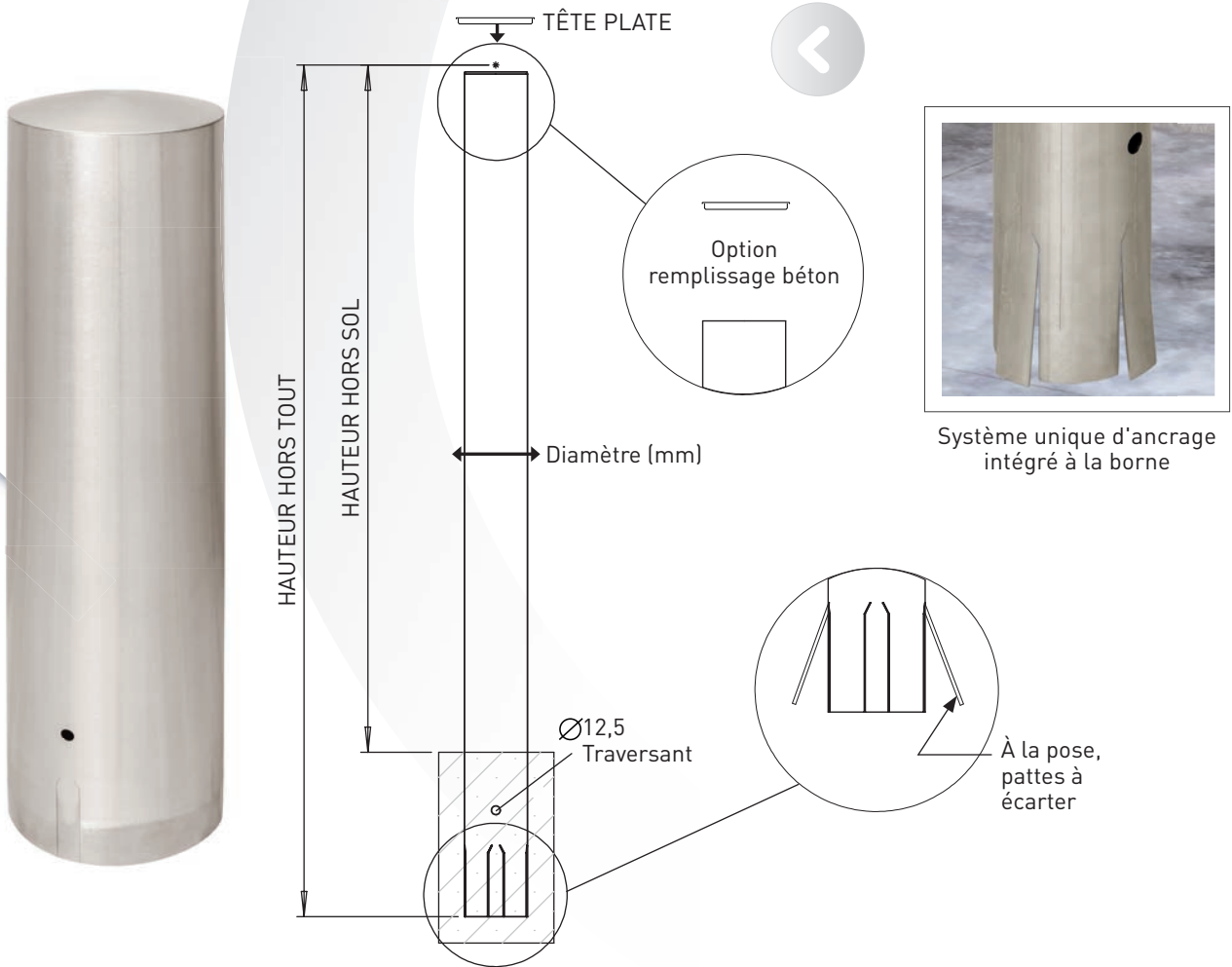

FIXATIONS

À sceller ou sur platine



MATIÈRE

304 - 316



DIAMÈTRES

60.3 | 76.1 | 88.9
104 | 114.3 | 139.7
154 | 204 | 219 | 254



HAUTEURS

HORS SOL	HORS TOUT
500	750
750	1000
1000	1200
1200	1500



OPTION

Détail en page 9

> OPTIONS BORNES



Double gorge



Bande réfléchissante



Brillant



Bande microbillée



Fixation sur platine



Version anti bélière
tête avec tige
pour remplissage béton

BORNES

> ANCRAGE & NORMES

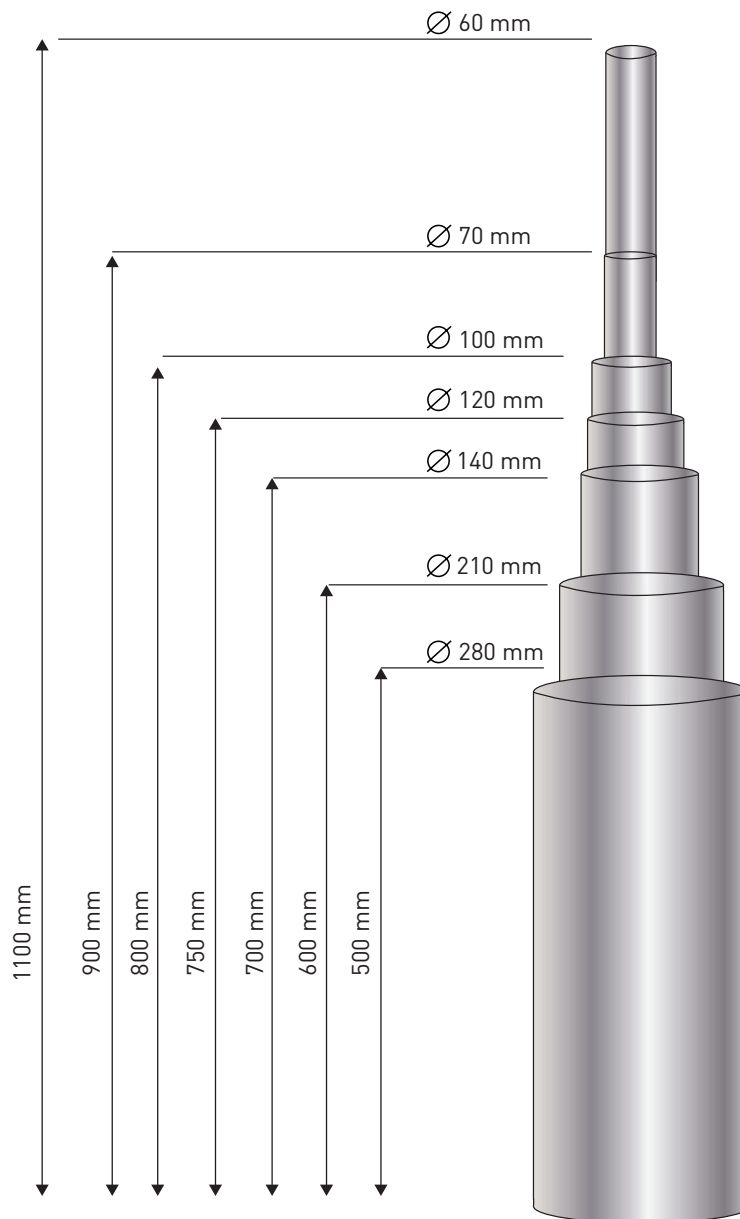

ABAQUE NORME

SCELLEMENT STANDARD

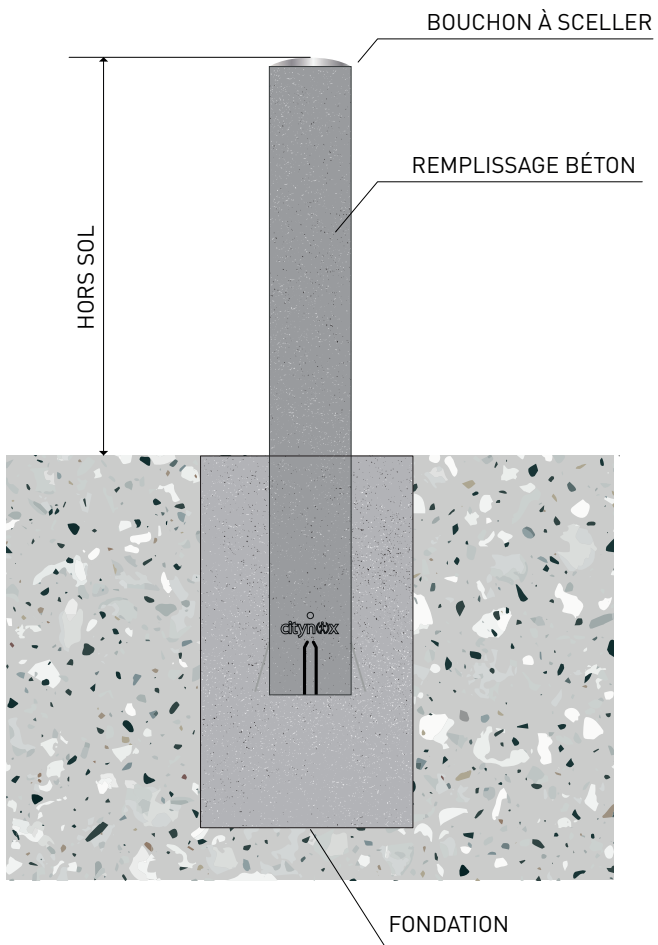

CHEMISAGE DE BORNE EXISTANTE



SCELLEMENT AVEC CHÂNAGE

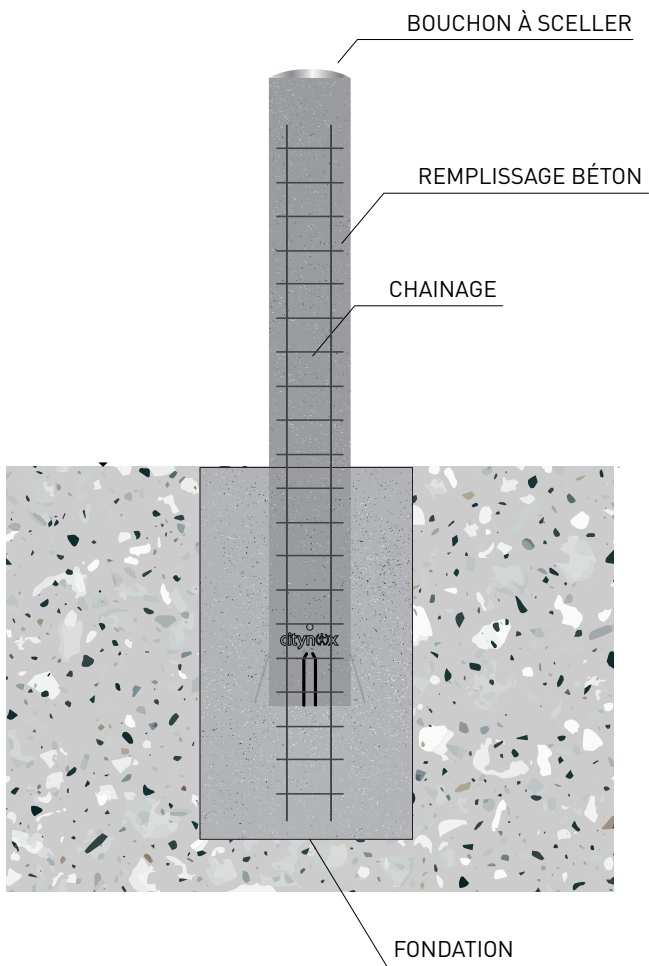

SCELLEMENT SUR IPN

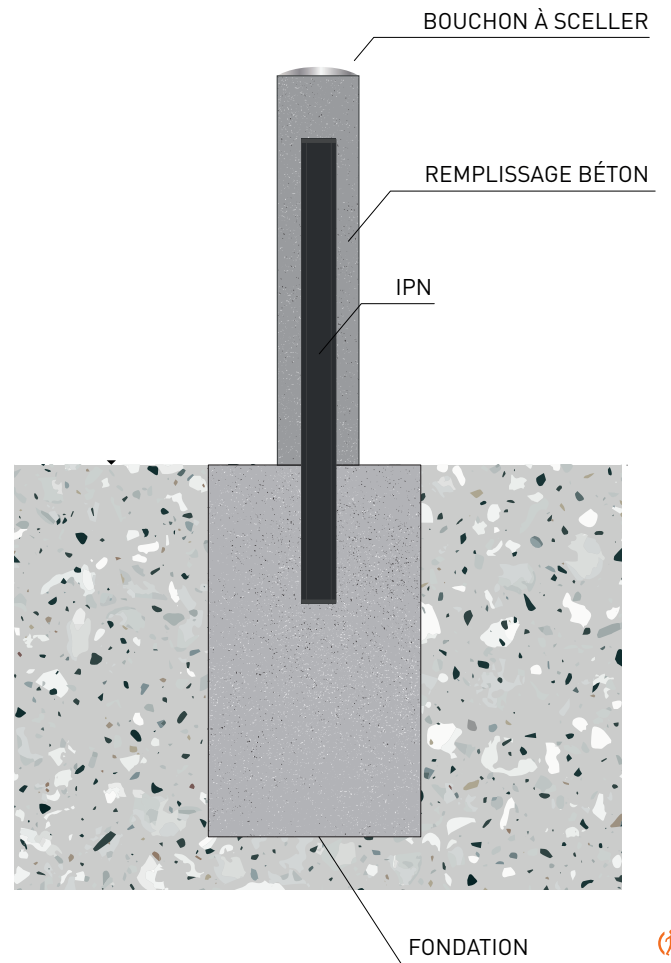

BORNES AMOVIBLES PAR CLÉ TRIANGLE

> TOSCANE & ANDRIA

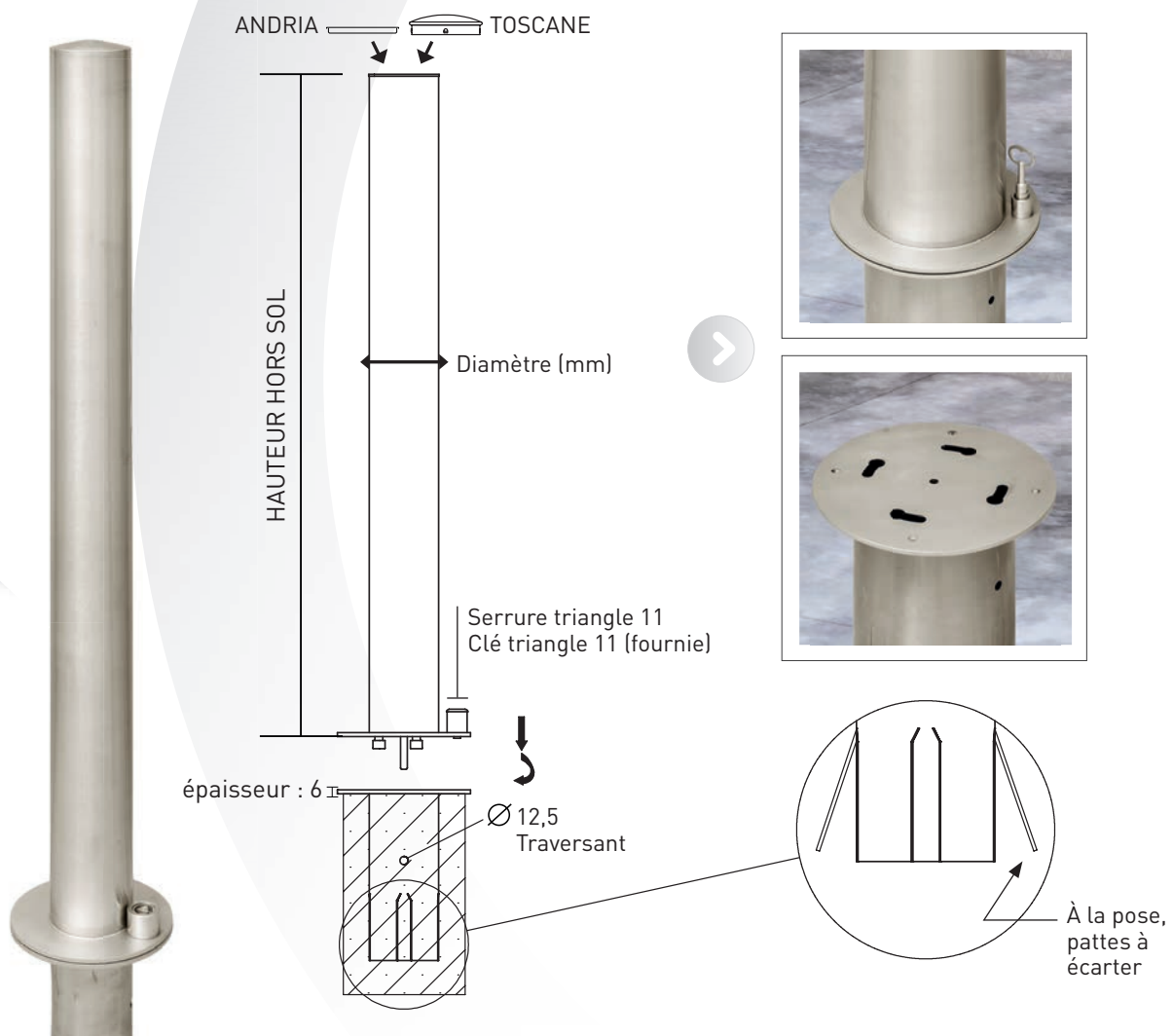

FIXATION
Amovible par
clé triangle de 11



MATIÈRE
304 - 316



DIAMÈTRES
76.1 | 88.9 | 104
114.3 | 139.7 | 154
204 | 219 | 254



HAUTEURS
HORS SOL
500
750
1000
1200



TOSCANE & ANDRIA





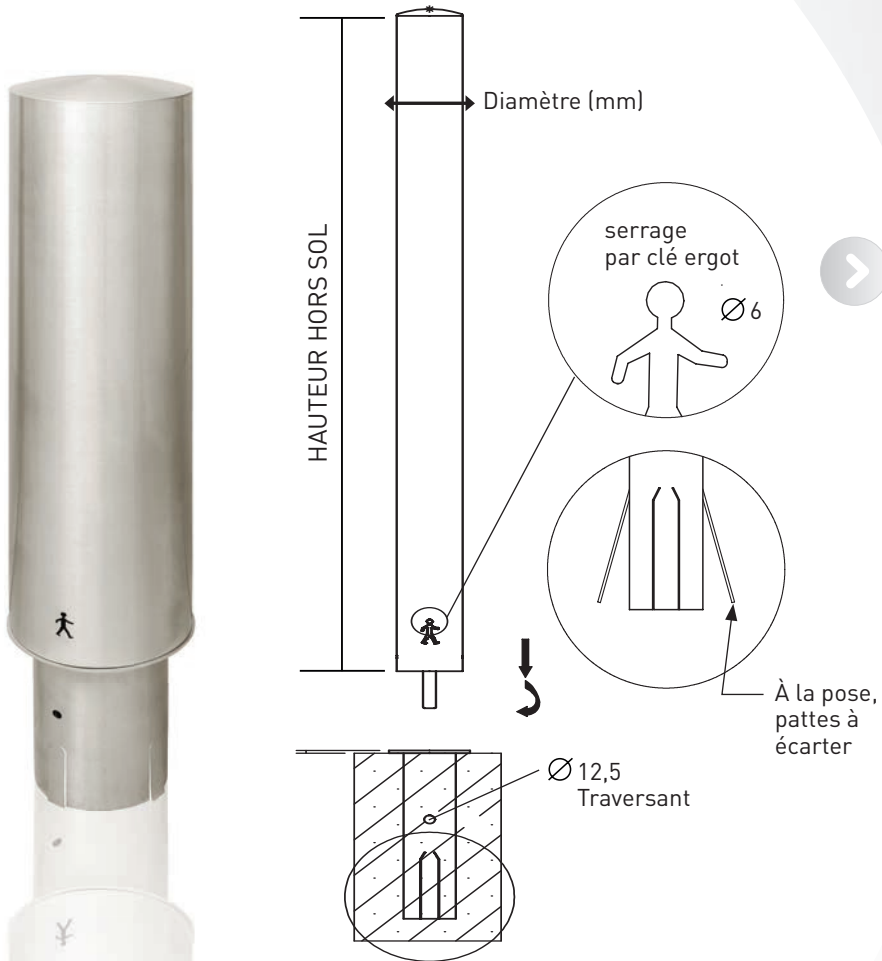

ANDRIA  TOSCANE 

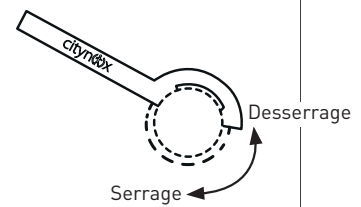

Option clé ergot Citynox



 <p>FIXATION Amovible par clé ergot (clé non fournie)</p>	 <p>MATIÈRE 304 - 316</p>	 <p>DIAMÈTRES 60.3 76.1 88.9 104 114.3 139.7 154 204 - 254</p>	 <p>HAUTEURS HORS SOL 500 750 1000 1200</p>
-----------------------------------------------------------------------------------------------------------------------------------------------------------------	-------------------------------------------------------------------------------------------------------------------------	--------------------------------------------------------------------------------------------------------------------------------------------------------------------------------	-------------------------------------------------------------------------------------------------------------------------------------------------------------



ARCEAUX VÉLOS

ARCEAUX VÉLOS

> NORÉA

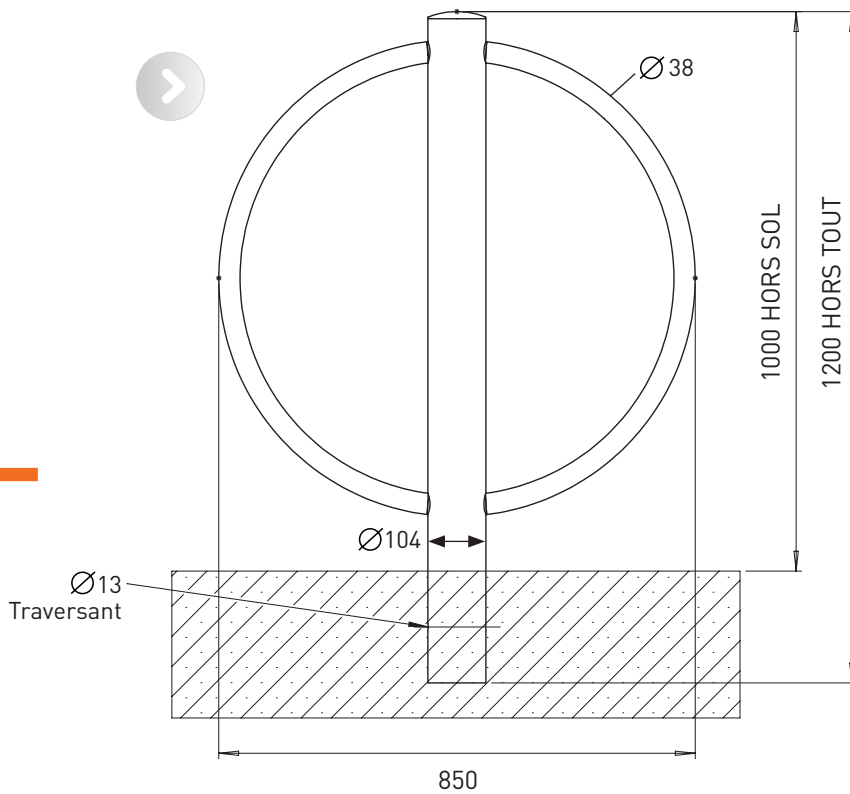

FIXATIONS
À sceller ou
sur platine



MATIÈRE
304 - 316



DIAMÈTRE
104



HAUTEURS
HORS TOUT
1000 hors tout - 1200 hors tout



OPTIONS
Plaque vélo ou
plaque personnalisée
Rondelle de finition

ARCEAUX VÉLOS

> TOSCANE

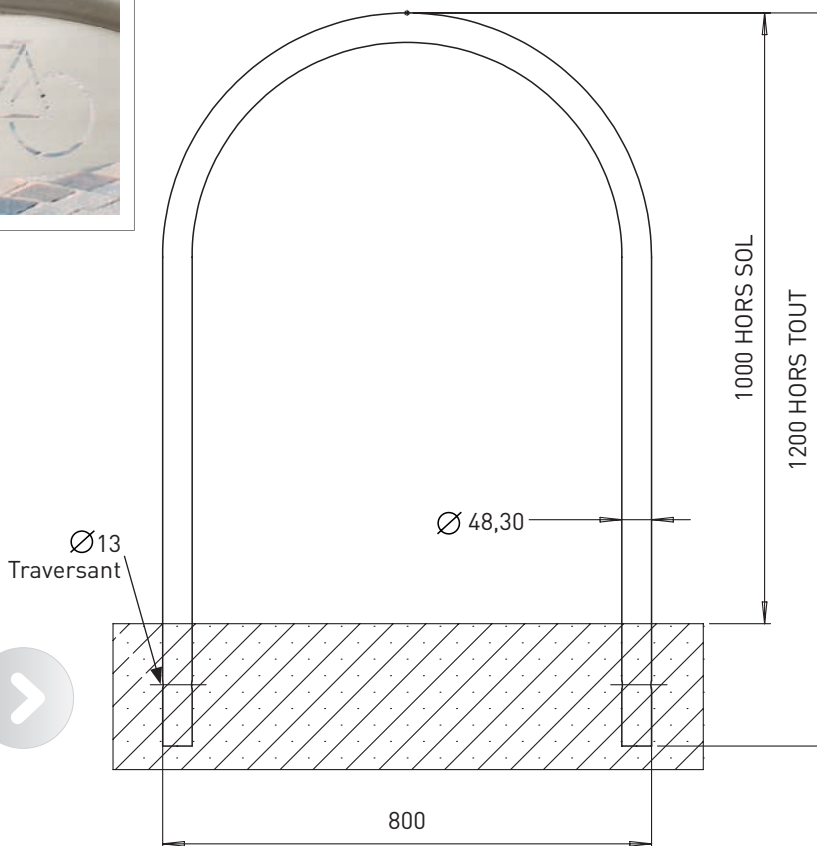

FIXATIONS
À sceller ou
sur platine



MATIÈRE
304 - 316



DIAMÈTRE
48



HAUTEURS
HORS TOUT
1000 hors tout - 1200 hors tout



OPTIONS
Plaque vélo ou
plaque personnalisée
collerettes de finition

ARCEAUX VÉLOS

> ANDRIA

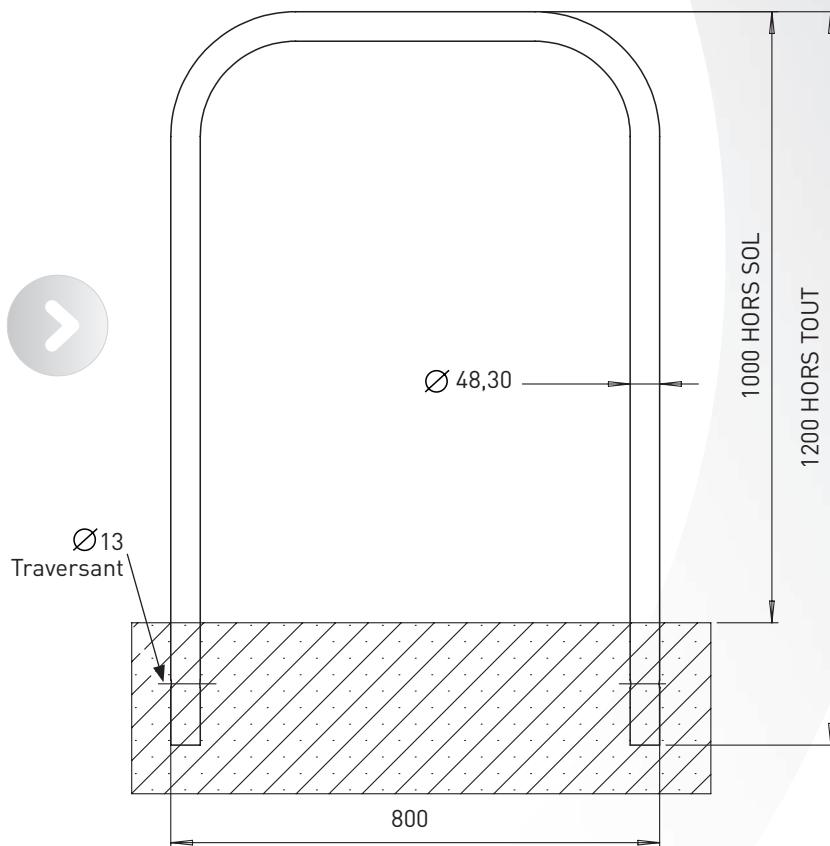

FIXATIONS
À sceller ou
sur platine



MATIÈRE
304 - 316



DIAMÈTRE
48



HAUTEURS
HORS TOUT
1000 hors tout - 1200 hors tout



OPTIONS
Plaque vélo ou
plaque personnalisée
collerettes de finition

ARCEAUX VÉLOS

> ÉOLE

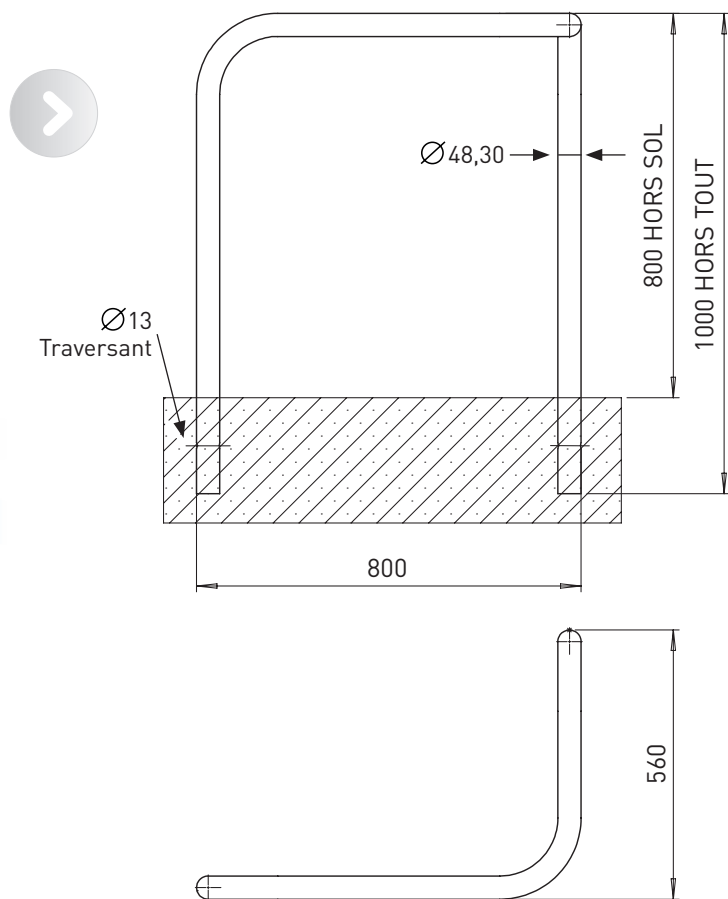

FIXATIONS
À sceller ou
sur platine



MATIÈRE
304 - 316



DIAMÈTRE
48



HAUTEURS
HORS TOUT
1000 hors tout - 1200 hors tout



OPTIONS
Plaque vélo ou
plaque personnalisée
collerettes de finition

ARCEAUX VÉLOS

> MULTI

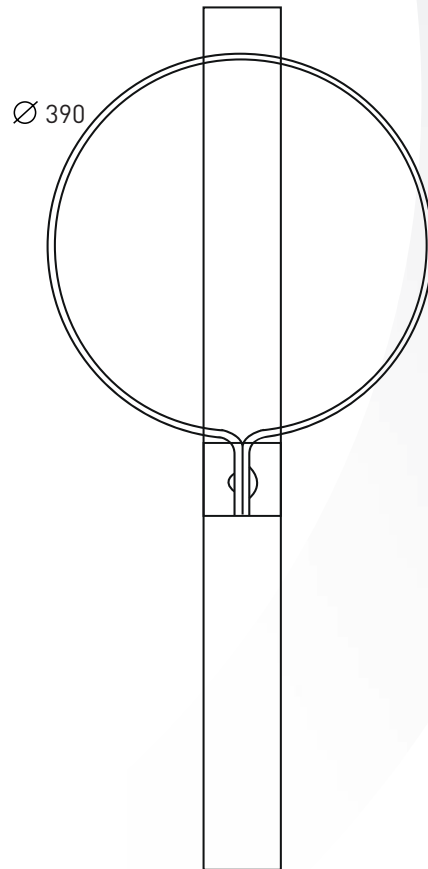
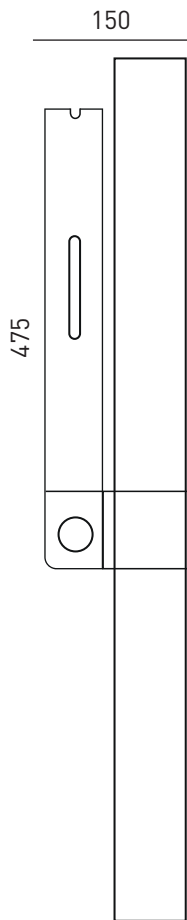





CLOUS

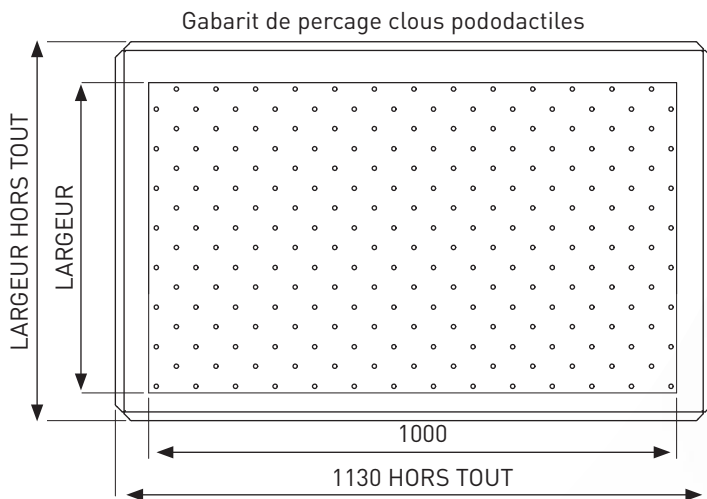
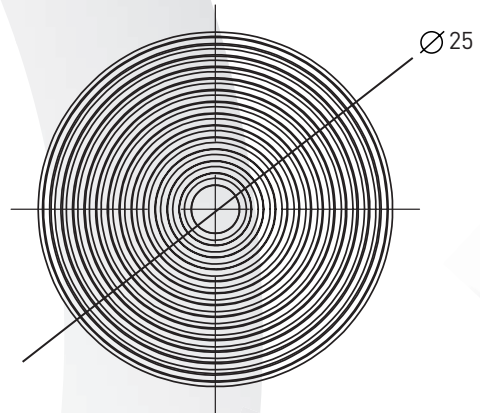
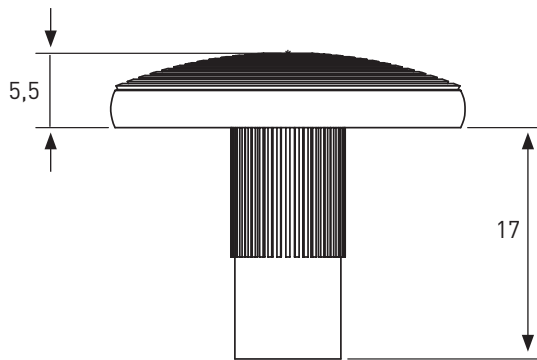

CLOUS PODOTACTILES



 <p>FIXATION À sceller</p>	 <p>MATIÈRE 304 - 316</p>	 <p>DIAMÈTRE 25</p>	 <p>FINITION Podotactile</p>	 <p>OPTION Couleur noire</p>
--------------------------------------------------------------------------------------------------------------------------	-------------------------------------------------------------------------------------------------------------------------	-------------------------------------------------------------------------------------------------------------------	-----------------------------------------------------------------------------------------------------------------------------	------------------------------------------------------------------------------------------------------------------------------

CLOUS URBAINS

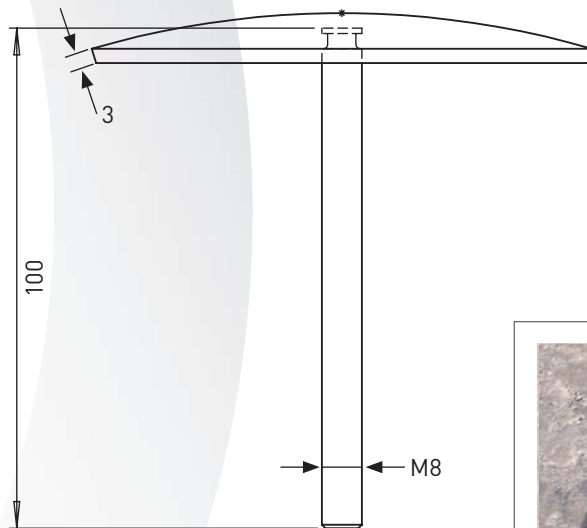

FIXATION
À sceller



MATIÈRE
304 - 316



DIAMÈTRES
80 - 100 - 120
150 - 200



FINITIONS
Brossé - strié
brillant - laiton



OPTIONS
Numéro - PMR - vélo
piéton - personnalisation
sur demande



Brossé



Strié



Brillant



Laiton brossé



Logo PMR



Logo Vélo

CENDRIER

TÊTE AMOVIBLE
PAR SERRURE

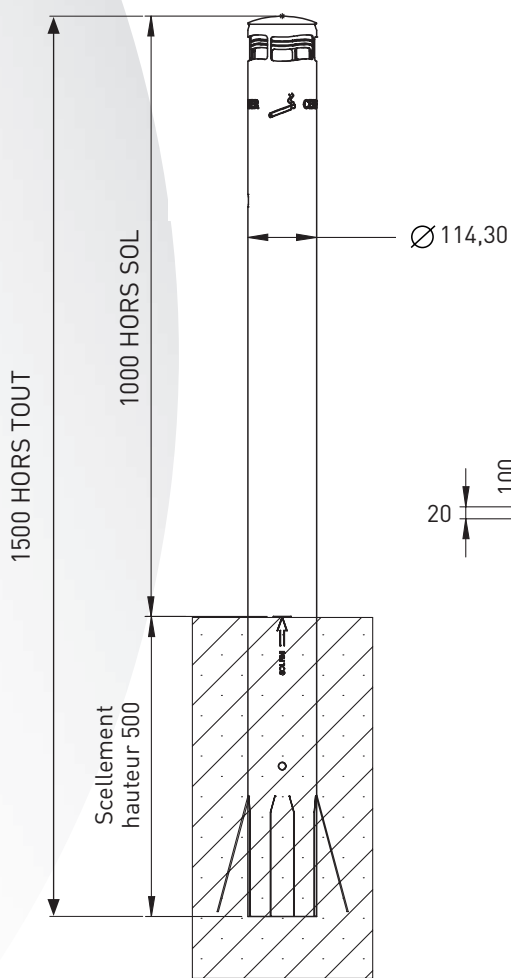

UN ENTRETIEN SIMPLE

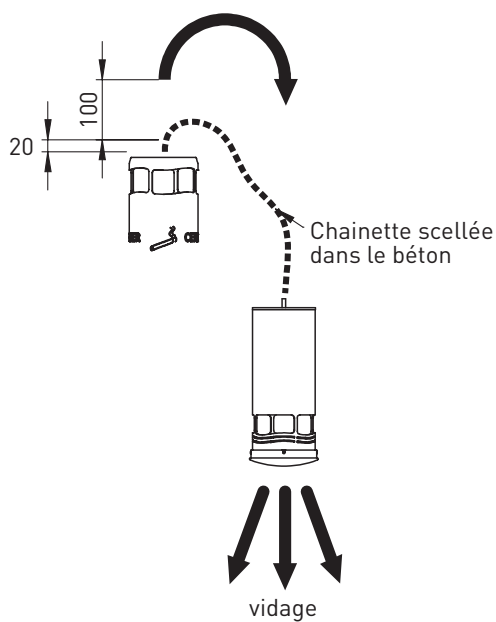

FIXATIONS

Mural,
à sceller,
sur platine



MATIÈRE

316



DIAMÈTRE

114



FINITION

Brossé



HAUTEURS

1500
420



OPTION

Personnalisation

CORBEILLE

> TOSCANE

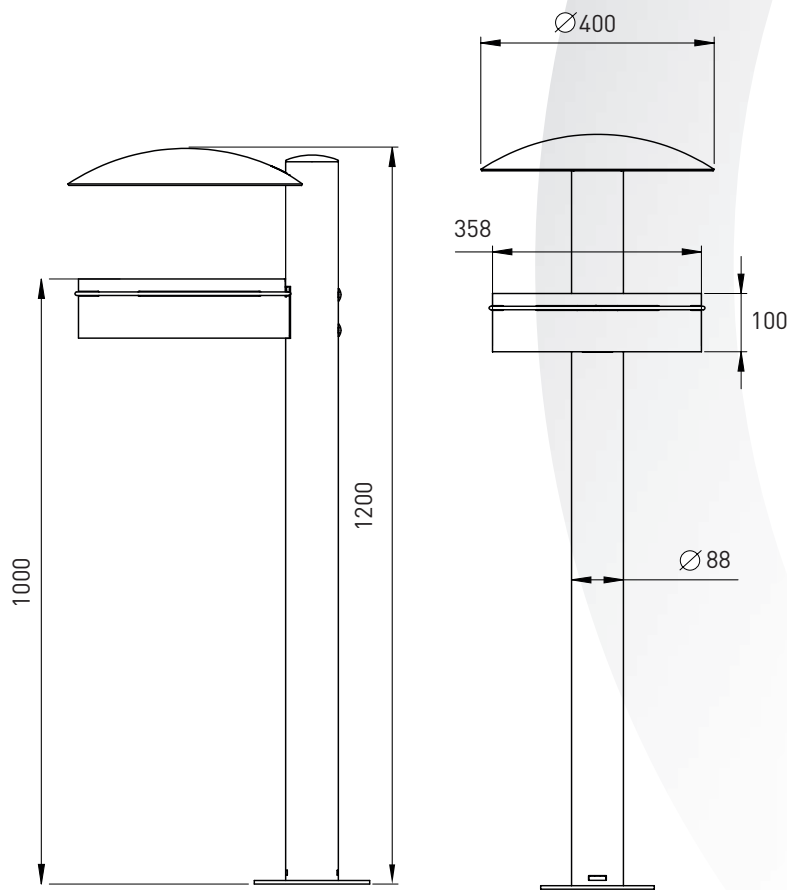

FIXATIONS
À sceller
sur platine



MATIÈRE
304 - 316



DIAMÈTRE
88



FINITION
Brossé



HAUTEURS
1000
1200



LES AUTRES ➤ PRODUITS



➤ PARC À CHARIOTS





> PROTECTIONS D'ANGLE
2 pieds ou 3 pieds

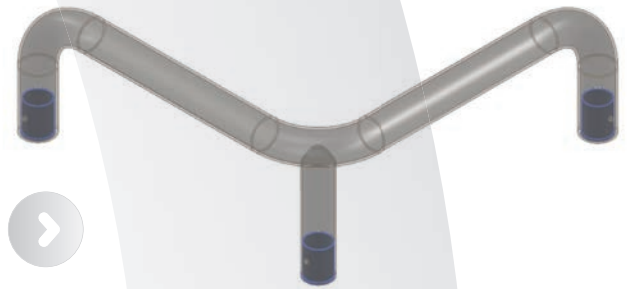

**> PROTECTION
CANDÉLABRE**



**> PROTECTION
LAMPADAIRE**





LES AUTRES ➤ PRODUITS

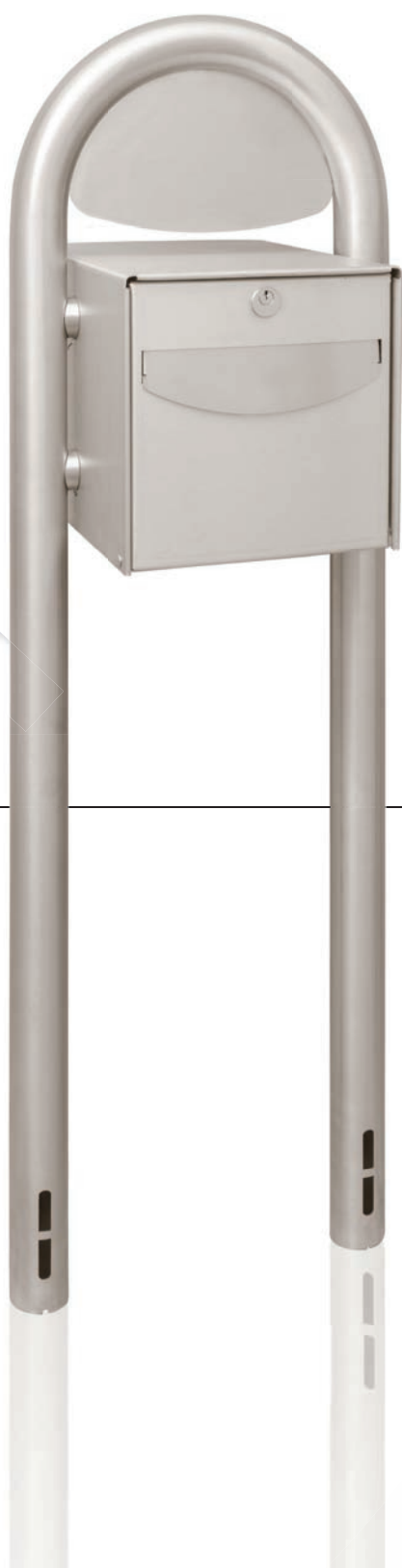

➤ LA BOÎTE À LETTRE FIXE
ANTI-VANDALISME





> DOUBLE CORBEILLE

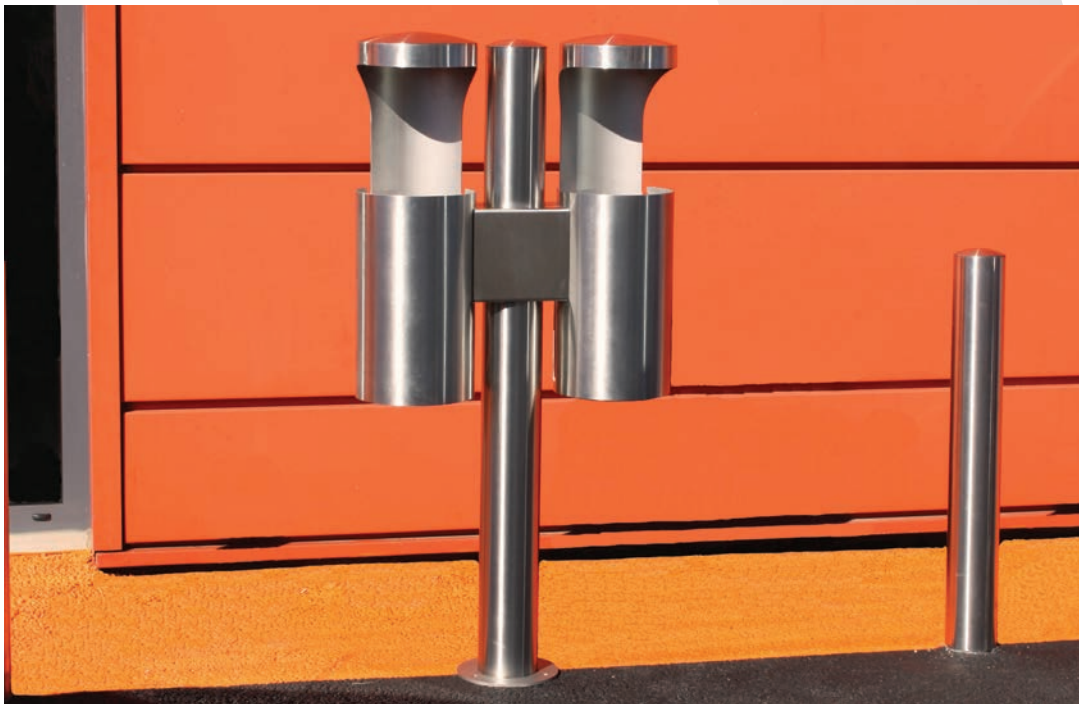

> CORBEILLE



> BANC





cityn()x

w w w . c i t y n o x . f r



1 Chemin des deux Mas
30100 ALÈS

T : 04 66 30 60 89

Mail : commercial@citynox.fr

GPS : 44.160045 (lat) 4.085154 (long)





L'INOX DANS TOUS SES ETATS !

