

3R15/320
3R20/320

Dati tecnici Technical data	3R15/320	3R20/320
Camera di lavoro (mm) Shredding chamber (mm)	1500x1250	1950x1250
Lame da 50 mm (n.) 50 mm blades (no.)	45	58
Lame da 75mm (n.) 75mm blades (no.)	30	39
Potenza (kW) Power (kW)	160+75	160+75
Tensione (V) Voltage (V)	220/400/460	220/400/460
Peso (kg) Weight (kg)	14000+1620+2580	16000+1620+2580

Dati Tecnici/Technical Data

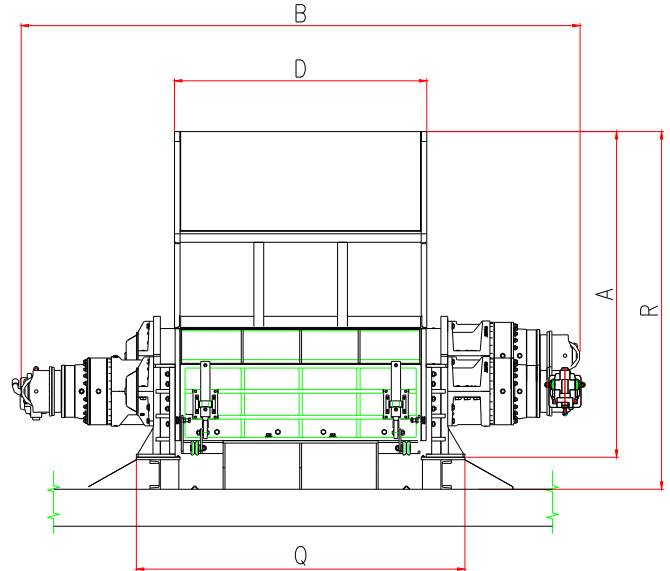
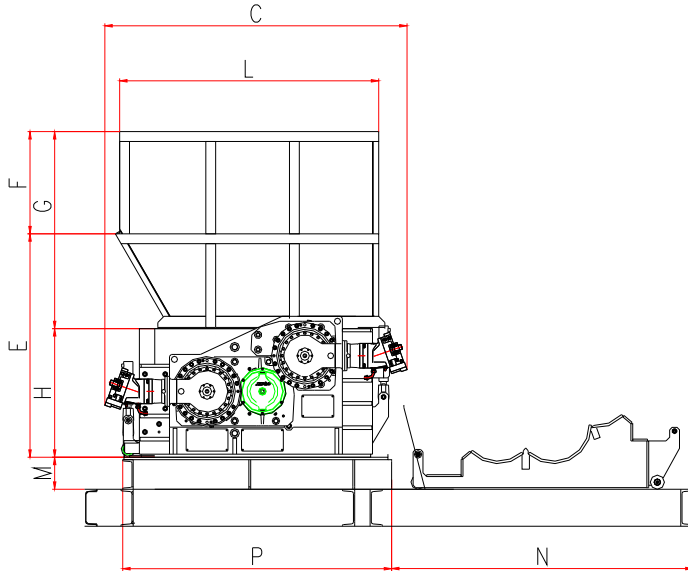

Esempi di materiali trattati / Some applications:

Rifiuti solidi urbani <i>Urban waste</i>		3÷8 t/h - 6÷10 t/h
Rifiuti ospedalieri <i>Hospital waste</i>		2÷4 t/h - 3÷6 t/h
Rifiuti tossici industriali <i>Hazardous waste</i>		2÷5 t/h - 4÷7 t/h
Scarti da cartiera <i>Paper factory waste(Pulper)</i>		1÷2 t/h - 4÷7 t/h

	3R15/320	3R20/320
A	2650	2650
B	4100	4550
C	2500	2500
D	2000	2500
E	1800	1800
F	850	850
G	1600	1600
H	1050	1050
L	2100	2100
M	260	260
N	2500	2500
P	2200	2200
Q	2220	2670
R	2910	2910

CAT1019 Rev. A 04/15

SatrindTech S.r.l.

Via Monfalcone, 122 - 20010 Arluno (MI) - Italy

Tel. (+39) 02 90376683

Fax (+39) 02 90376721

info@satrindtech.com

www.satrindtech.com

