

# ADRIATECH

## SSCW Equipment

Unmatched combination of exceptional design and premium technologies for faster return on investment and higher profitability per square meter.

2023



AT

## Every single square matters. In the car washing business, every single square meter is **essential**.

Equipping the car wash with Adriateh's additional equipment and peripherals is the fastest and most effective way to increase revenue per square meter.

In a competitive business environment, every advantage counts. For businesses that are limited by the size of their lot, such as self-service car wash stations, the importance of every single square meter cannot be overstated. In fact, it can be the difference between success and failure.

Adriateh's equipment is a perfect complement to car washes. It saves space and allows owners to generate higher revenue, achieve better ROI, and increase profitability per square meter. Car wash owners are not the only ones who will benefit. The multifunctional equipment will also delight car wash customers, who will be able to clean their vehicles faster and more easily.

By providing a superior car washing experience, these businesses can enhance their reputation and attract a loyal customer base.

The equipment we developed in our own research and development center has been proven in practice at over 1000 locations in 40 countries. It enables owners to achieve higher revenue, and provides customers with a better washing experience.

We are confident that it can improve your business as well.

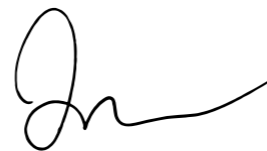

Our **Stekerr P2** EV charging station is the winner of the **iF Design Award 2023**



## Additional equipment - a series of outstanding devices for higher profitability of the car wash **wash station**

The effectiveness of our devices has been proven through thousands of car washes in more than 40 countries.

Offer them additional services and the process of washing and cleaning vehicles will not end with the final rinse and exit from the wash bay. On the contrary - that is the moment when the second phase of vehicle cleaning can begin.

With that in mind, Adriateh has designed and produced a series of outstanding devices that will provide your car wash with additional revenue streams and help you shorten the return on investment. The possibilities for treating vehicles after washing are numerous - from vacuuming and chemical cleaning of the interior to applying tire shine or topping up windshield washer fluid.

The flagship of our line of additional equipment are multifunctional devices with multiple functions in one housing. This is precisely the feature that will dramatically increase the profitability per square meter of your business.





# Multiqe Maxi<sup>TM</sup> Series

Maxi version of our best-selling machine! As much as 5 functions in a single robust stainless steel housing.

The latest addition to the Multiqe series is versatile and multifunctional, just like its smaller siblings. With up to five different functions in a robust stainless steel housing, color touchscreen, and compatibility with all payment methods.

Although it's the Maxi version, rest assured that this Multiqe will save you space, provide a high ROI, and increase profitability per square meter.



\*picture does not represent all possible combinations of product

## Functions



Vacuum cleaner



Tyre inflator



Windscreen liquid / Water



Interior fragrance



Tyre shiner

## Payment methods

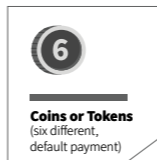

Coins or Tokens  
(six different, default payment)

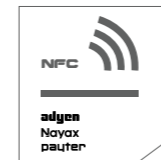

NFC  
adym  
Noyax  
DAUER

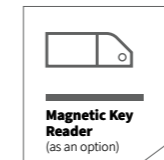

Magnetic Key Reader  
(as an option)

## Packaging dimensions

One Multiqe Maxi per euro pallet

1200x800x75 mm

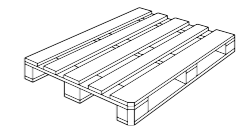

## Technical Specification

|  |                         |
|--|-------------------------|
| Voltage  | 400 / 50-60 Hz          |
| Maximum machine power  | 4700 W                  |
| Protection / Protection class                                  | 10-16 A / I             |
| Maximum airflow (air) / suction power                          | 4000 l/min / -230 mbars |
| Type of protection   | IP 54                   |
| Multiqe Maxi noise level                                       | 86 dB                   |
| Vacuum cleaner suction hose - length / diameter                | 7 m / 40 mm             |
| Dust container capacity  | 50 l                    |
| Tyre inflator maximum power<br>*has to be adjusted by customer | 8 bars                  |
| Water pressure<br>*has to be adjusted by owner                 | 3-6 bars                |

## Dimensions

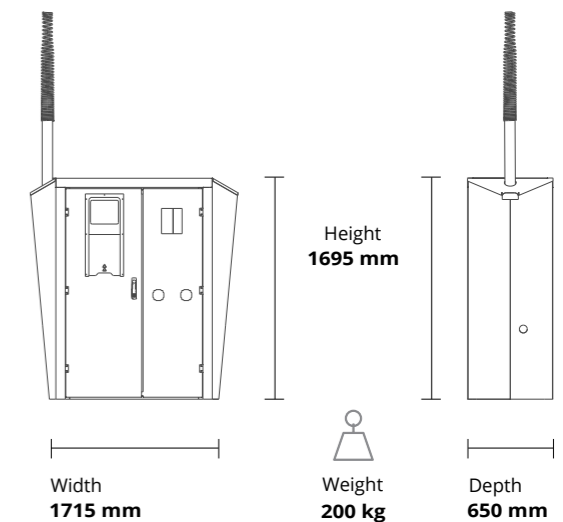

| Choose Yours              | 4 in 1 Product | 5 in 1 Product |
|---------------------------|----------------|----------------|
| Vacuum cleaner            | ✓              | ✓              |
| Windscreen liquid / Water | ✓              | ✓              |
| Tyre inflator             | ✓              | ✓              |
| Interior fragrance        | ✓              | ✓              |
| Tyre shiner               |                | ✓              |



# Multiqe™ Series

Our best-selling machine comes with as many as five functions in one housing.

Multitalented and multifunctional, just as its name suggests. Five different functions in a robust stainless steel housing, color touchscreen, and compatibility with all payment methods.

Multiqe saves your space, provides a high ROI, and can be customized to best fit your visual identity.



\*picture does not represent all possible combinations of product

| Choose Yours |                    | 4 in 1 Vacuum Cleaner | 5 in 1 Vacuum Cleaner | 4 in 1 Dry Cleaner | 5 in 1 Dry Cleaner |
|--------------|--------------------|-----------------------|-----------------------|--------------------|--------------------|
| CORE         | Vacuum cleaner     | ✓                     | ✓                     |                    |                    |
|              | Dry cleaner        |                       |                       | ✓                  | ✓                  |
|              | Waste bin          | ✓                     | ✓                     | ✓                  | ✓                  |
| EXTRA        | Tyre shiner        | ✓                     | ✓                     | ✓                  | ✓                  |
|              | Interior fragrance |                       | ✓                     |                    | ✓                  |
|              | Air blower         | ✓                     | ✓                     | ✓                  | ✓                  |

## Functions



Vacuum cleaner



Dry cleaner



Tyre shiner



Interior fragrance



Air blower

## Payment methods

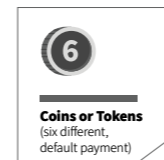

Coins or Tokens (six different, default payment)



NFC adyen, Nayax, paayer



Magnetic Key Reader (as an option)

## Packaging dimensions

One Multiqe per euro pallet

1200x800x75 mm

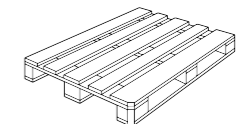

## Technical Specification

|   |                         |
|---|-------------------------|
| Voltage   | 400 / 50-60 Hz          |
| Maximum machine power                           | 3160-4500 W             |
| Protection                                      | 16 A                    |
| Protection class                                | I                       |
| Maximum airflow (air) / suction power           | 4000 l/min / -230 mbars |
| Type of protection                              | IP 55                   |
| Vacuum cleaner noise level                      | 86 dB                   |
| Vacuum cleaner suction hose - length / diameter | 7 m / 40 mm             |
| Dust container capacity                         | 50 l                    |

## Dimensions

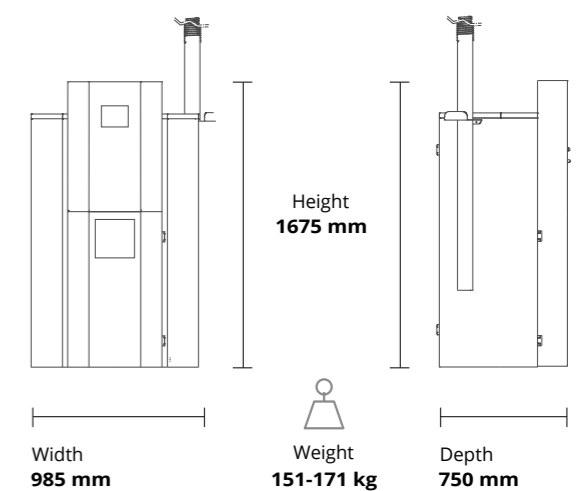

**SINGLE  
FUNCTION**

**24**  
Months  
EU Warranty

**INOX  
304**  
Inox 304 AISI  
Stainless Steel

# Net™ Series

Single function in a robust and compact stainless steel housing.

Depending on your needs, this device can be a vacuum cleaner, dry cleaner, or tire inflator. It is compatible with all payment methods.

The NET model saves space and provides additional revenue to your car wash station.



\*picture does not represent all possible combinations of product

## Functions



Vacuum cleaner



SC Vacuum cleaner



Tyre inflator



Dry cleaner

## Payment methods

**6**  
Coins or Tokens  
(six different, default payment)

**NFC**  
adym  
Novax  
DAUER

**Magnetic Key Reader**  
(as an option)

## Packaging dimensions

Two Nets  
per euro pallette

1200x800x75 mm

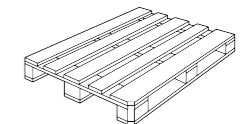

## Technical Specification

|   |                         |
|---|-------------------------|
| Voltage                                   | 230-400 / 50 Hz         |
| Maximum machine power                     | 2450-3000 W             |
| Protection / Protection class             | 10-16 A / I             |
| Type of protection                        | IP 54-55                |
| Suction tube - length / diameter          | 7 m / 40 mm             |
| Flexible suction hose - length / diameter | 6 m/40 mm               |
| Tank volume (chemistry / vacuum cleaner)  | 25/50 l                 |
| Maximum airflow (air) / suction power     | 4000 l/min / -230 mbars |
| Degree of radio interference suppression  | N                       |
| Vacuum cleaner noise level                | 86 dB                   |
| Tyre inflator maximum power               | 8 bars                  |

## Dimensions

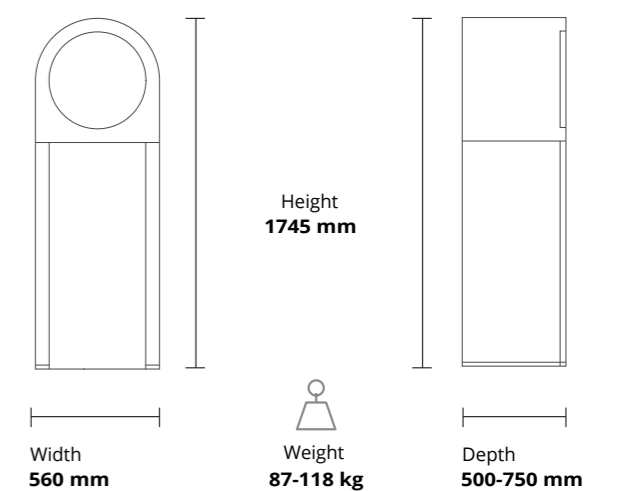

| Choose Yours      | Product One <sup>1</sup> | Product Two <sup>1</sup> | Product Three <sup>2</sup> | Product Four |
|-------------------|--------------------------|--------------------------|----------------------------|--------------|
| Vacuum cleaner    | ✓                        |                          |                            |              |
| SC Vacuum cleaner |                          | ✓                        |                            |              |
| Tyre inflator     |                          |                          | ✓                          |              |
| Dry cleaner       |                          |                          |                            | ✓            |

<sup>1</sup> Option: Hose carrier with spring  
<sup>2</sup> Option: With or without payment

**SINGLE FUNCTION**



# Quado™ Series

Robust stainless steel housing with a single function.

Depending on your needs, the Quado model comes as a vacuum cleaner, tyre inflator, tyre shiner, or reservoir containing windscreen liquid or interior fragrance.



\*picture does not represent all possible combinations of product

### Functions



Vacuum cleaner



Tyre shiner



Tyre inflator



Interior fragrance



Windscreen liquid

### Payment methods

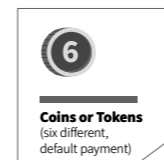

Coins or Tokens  
(six different, default payment)

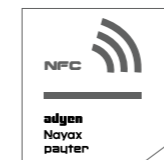

NFC  
adym  
Nayax  
DAUTER



Magnetic Key Reader  
(as an option)

### Packaging dimensions

Two Quados per euro pallet

1200x800x75 mm

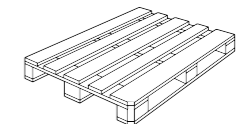

### Technical Specification

|  |                         |
|--|-------------------------|
| Voltage                                  | 230-400 / 50 Hz         |
| Maximum machine power                    | 2450-3000 W             |
| Protection / Protection class            | 10-16 A / I             |
| Type of protection                       | IP 54-55                |
| Suction hose - length / diameter         | 7 m / 40 mm             |
| Spiral hose - length / diameter          | 8 m / 50 mm             |
| Tank volume                              | 50 l                    |
| Maximum airflow (air) / suction power    | 4000 l/min / -230 mbars |
| Degree of radio interference suppression | N                       |
| Vacuum cleaner noise level               | 86 dB                   |
| Tyre inflator maximum power              | 8 bars                  |

### Dimensions

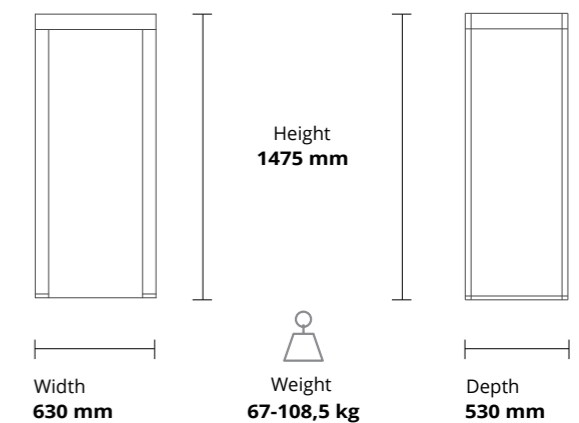

Choose Yours



|                    | Product One <sup>1</sup> | Product Two <sup>2</sup> | Product Three | Product Four | Product Five |
|--------------------|--------------------------|--------------------------|---------------|--------------|--------------|
| Vacuum cleaner     | ✓                        |                          |               |              |              |
| Tyre inflator      |                          | ✓                        |               |              |              |
| Tyre shiner        |                          |                          | ✓             |              |              |
| Interior fragrance |                          |                          |               | ✓            |              |
| Windscreen liquid  |                          |                          |               |              | ✓            |

<sup>1</sup> Option: Hose carrier with spring

<sup>2</sup> Option: With or without payment



# Quado Duo <sup>TM</sup> Series

Robust stainless steel housing with a single function.

Two functions in one device will save you space and increase revenue. Choose a predefined duo combination that best suits the needs of your car wash.



\*picture does not represent all possible combinations of product

### Functions



Tyre shiner



Interior fragrance



Windscreen liquid



Tyre inflator

### Payment methods

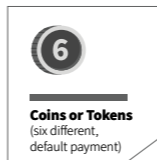

Coins or Tokens  
(six different, default payment)



NFC  
edym  
Nayax  
DAUTER



Magnetic Key Reader  
(as an option)

### Packaging dimensions

Two Quado Duos per euro pallet

1200x800x75 mm

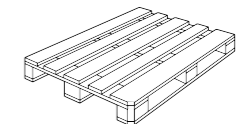

### Technical Specification

|  |                |
|--|----------------|
| Voltage                                  | 230 / 50-60 Hz |
| Maximum machine power                    | 1500 W         |
| Protection / Protection class            | 10-16 A / I    |
| Type of protection                       | IP 54          |
| Spiral hose - length / diameter          | 10 m / 8 mm    |
| Tank volume                              | 50 l           |
| Degree of radio interference suppression | N              |
| Tyre inflator maximum power              | 8 bars         |

### Dimensions

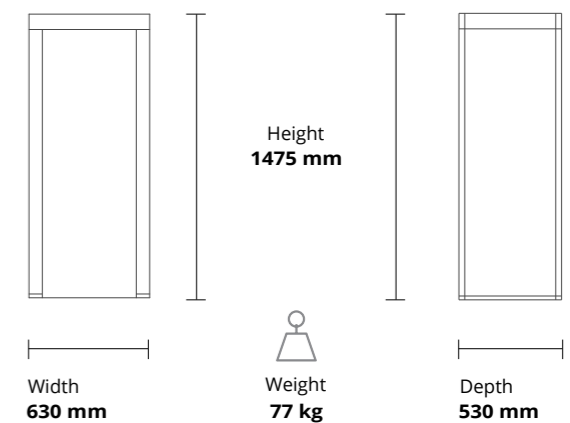

Choose Yours ➤

|                    | P1 | P2 | P3 | P4 | P5 <sup>1</sup> | P6 |
|--------------------|----|----|----|----|-----------------|----|
| Tyre shiner        | ✓  | ✓  |    |    |                 | ✓  |
| Interior fragrance |    | ✓  | ✓  | ✓  |                 |    |
| Windscreen liquid  |    |    |    | ✓  | ✓               | ✓  |
| Tyre inflator      | ✓  |    | ✓  |    | ✓               |    |

<sup>1</sup> Option: One or two payments



**SINGLE  
FUNCTION**

**24**  
Months  
EU Warranty

**INOX**  
304  
Inox 304 AISI  
Stainless Steel

# Mali™ Series

Single function in a compact, monolithic stainless steel casing.

Depending on your needs, the Quado model comes as tyre shiner, wheel-and-insect remover, or reservoir containing windscreen liquid or interior fragrance.



\*picture does not represent all possible combinations of product

## Functions



1 Tyre shiner



2 Insects remover



3 Interior fragrance



4 Windscreen liquid

## Payment methods

**6**  
Coins or Tokens  
(six different,  
default payment)

**Magnetic Key Reader**  
(as an option)

## Packaging dimensions

Four Malis  
per euro palette

1200x800x75 mm

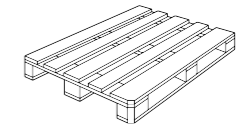

## Technical Specification

|  |                |
|--|----------------|
| Voltage                                  | 230 / 50-60 Hz |
| Maximum machine power                    | 2450 W         |
| Protection                               | 10 A           |
| Protection class                         | I              |
| Type of protection                       | IP 42-54       |
| Spiral hose - length / diameter          | 10 m / 8 mm    |
| Tank volume                              | 30 l           |
| Degree of radio interference suppression | N              |

## Dimensions

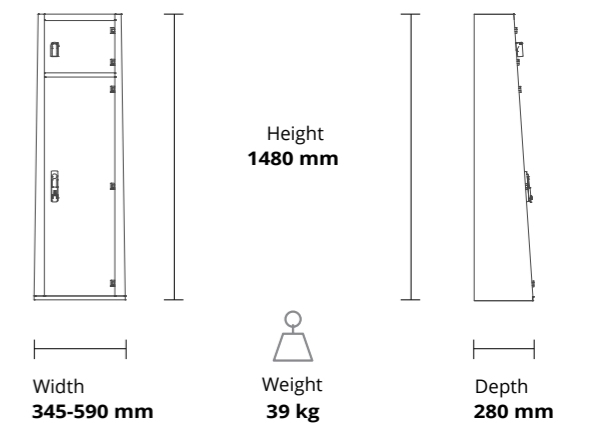

| Choose Yours       | Product One | Product Two <sup>2</sup> | Product Three | Product Four <sup>1</sup> |
|--------------------|-------------|--------------------------|---------------|---------------------------|
| Tyre shiner        | ✓           |                          |               |                           |
| Insects remover    |             | ✓                        |               |                           |
| Interior fragrance |             |                          | ✓             |                           |
| Windscreen liquid  |             |                          |               | ✓                         |

<sup>1</sup> Option: With or without payment  
<sup>2</sup> Option: Insects remover or Wheel cleaner



# Our Solutions



IN-HOUSE  
PRODUCTION

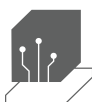

ADVANCED  
ELECTRONICS



CUTTING-EDGE  
MACHINERY

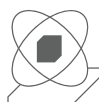

INTEGRATED  
ECOSYSTEM

## Adriateh is one of the leading European manufacturers of self-service car washes

We have been creating new trends in the self-service car wash market since 1996, providing our customers with excellent return on investment. Our exceptional technological solutions are accompanied by avant-garde patented aesthetics.

We are present in more than 40 countries, and so far we have participated in over 1500 projects of self-service car washes. All of our solutions are designed, developed, and produced in our own research and development center.

Adriateh d.o.o.  
Zagrebačka ulica 2  
10431 Novaki - Sv.Nedelja Croatia



Further information is available  
on the website [adriateh.hr](http://adriateh.hr)



We reserve the right to make technical changes and updates at any time. The values, characteristics, and other data as well as images and drawings that are mentioned or contained in this technical specification, prospectuses, and other offer documentation serve only as an example and are subject to constant updating and adaptation. If we have not explicitly stated the data as binding, the respective data does not represent a guarantee. The information in the binding order confirmation or sales contract applies.