

**K 8/30**  
**K10/30**  
**K13/30**

Caractéristiques Technical data	K 8/30	K 10/30	K 13/30
Chambre de broyage (mm) Shredding chamber (mm)	758x850	1008x850	1258x850
Lames de 30 mm (u) 30 mm blades (no.)	25	33	41
Lames de 50 mm (u) 50 mm blades (no.)	15	20	25
Puissance électrique (kW) Power (kW)	22	22	22
Tension (V) Voltage (V)	220/400/460	220/400/460	220/400/460
Poids (kg) Weight (kg)	3600	4000	4400

Ces modèles sont disponibles en version "CL" - système de contre-lames, pour le broyage de déchets petits et homogènes.  
For small and uniform material shred size available version with "CL" Counter Blades System

# Documentation Technique / Technical Data

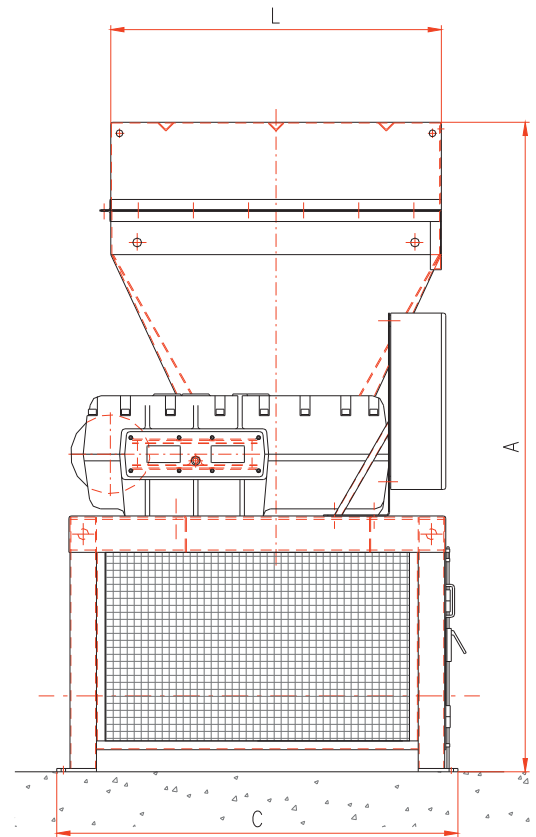
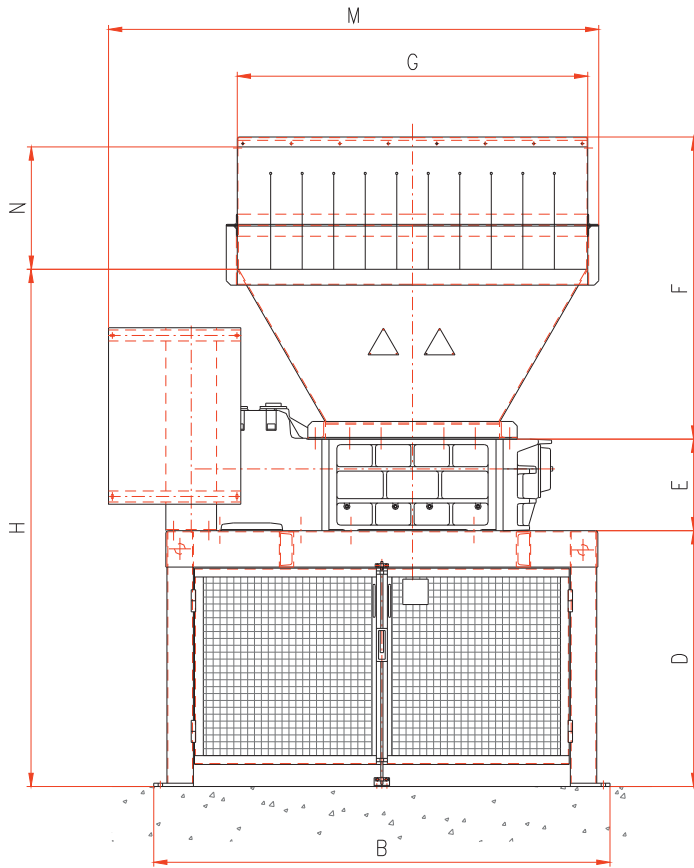

## Déchets traités / Some applications:

Fûts en plastique  
Plastics drums



0,6 ÷ 1,5 t/h

Déchets industriels  
Industrial scraps



0,6 ÷ 2 t/h

Boîtes de conserve (25-50 l)  
Tins (25-50 l)



0,6 ÷ 1,2 t/h

	K8/30	K10/30	K13/30
A	2945	2945	2945
B	2070	2170	2420
C	1820	1820	1820
D	1160	1160	1160
E	415	415	415
F	1370	1370	1370
G	1590	1840	2090
H	2345	2345	2345
L	1500	1500	1500
M	2225	2450	2700
N	555	555	555

CAT1009 Rev. A 04/15

### SatrindTech S.r.l.

Via Monfalcone, 122 - 20010, Arluno (MI) - Italie  
Tel. (+39) 02 90 37 66 83

sales@satrindtech.com  
satrindtech.com

### SatrindTech France - Groupe SEREX

19, chemin de la Violette, 31240 L'Union - France  
Tel. (+33) 05 62 89 08 88

contact@satrindtech-france.fr  
www.satrindtech-france.fr

