

## MRH 125

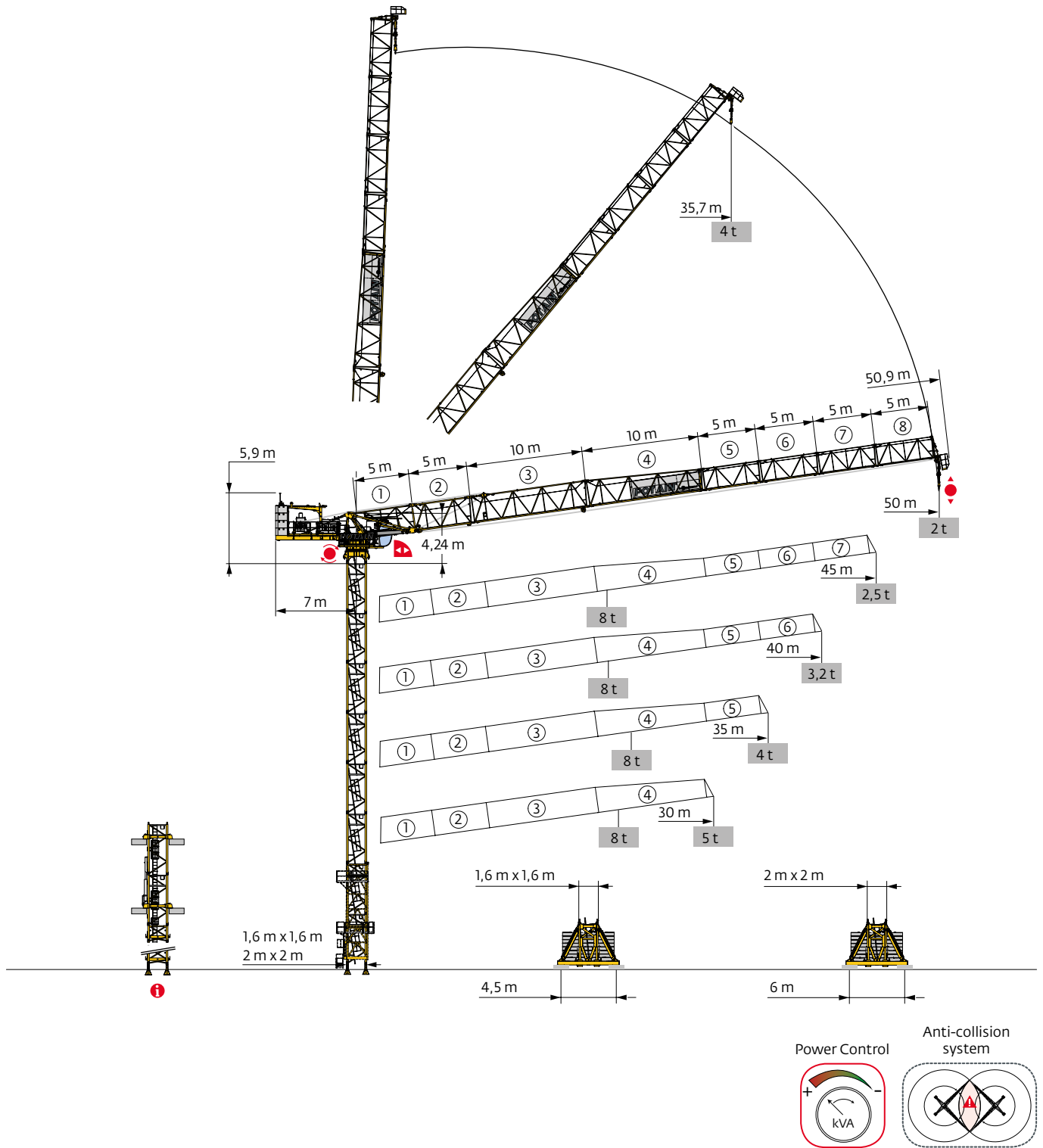

Mât - Réactions / Mast - Reaktionskräfte / Mast - Reactions / Mástil - Reacciones / Torre - Reazioni  
 Tramo - Reacções / Реакция опор мачты

1,6 m - P 41A - C50					
AVAIL (m)	30	35	40	45	50
↓ (m)	37,9	36,2	32,9	31,2	29,6
3,33 m	1	2	1	2	0
5 m	6	5	5	4	5
F2 (t)	● 123	124	121	122	121
	■ 183	192	186	194	197
F3 (t)	● 92	93	91	87	91
	■ 152	161	156	164	167
↓ (m) D50	34,6	31,2	27,9	26,2	24,6

1,6 m - S 41A - C50					
AVAIL (m)	30	35	40	45	50
↓ (m)	36,1	32,7	31,1	29,4	26,1
3,33 m	1	0	1	2	1
5 m	5	5	4	3	3
F1 (t)	● 77	76	77	80	76
	■ 87	83	88	92	88
↓ (m) D50	29,4	26,1	22,7	19,4	17,7

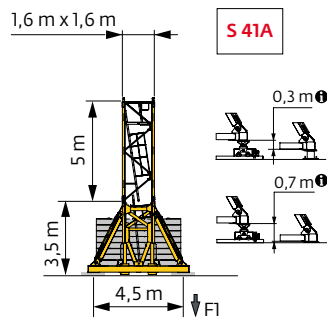
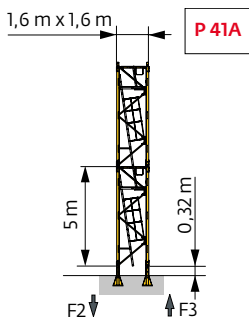

**i** Accès motorisés types Cab-IN et TCL : compositions de mâture, de lest de base et réactions adaptées. / Motorisierter Zugang vom Typ Cab-IN und TCL: Mastzusammensetzung, Grundballast und Reaktionskräfte sind angepasst. / Motorized accesses of Cab-IN and TCL types: Adapted mast composition, base ballast and reactions. / Acceso a cabina con elevador tipo Cab-IN (interno) y tipo TCL (externo): Adaptación de composición de mástil, lastre de base y reacciones. / Accessi motorizzati di tipo Cab-IN e TCL: composizioni elementi torre, zavorre di base e reazioni aggiornate. / Acessos motorizados tipo Cab-IN e TCL: composições de coluna, lastro da base e reacções adaptadas. / Лифты Cab-IN и TCL для подъема крановщиков: адаптированная композиция мачты, базовый балласт и нагрузки.

2 m - P 62B - C50					
ΔΔΔ (m)	30	35	40	45	50
↑ (m)	54,6	52,9	51,2	49,6	46,2
3,33 m	0	1	2	0	2
	5 m	10	9	9	7
F2 (t)	● 129	130	129	130	126
	■ 304	310	316	319	294
F3 (t)	● 94	91	94	92	92
	■ 269	276	282	285	261
↑ (m) D50	47,9	46,2	44,6	41,2	39,6

2 m - V 60A - C50					
ΔΔΔ (m)	30	35	40	45	50
↑ (m)	45,5	43,8	40,5	37,2	35,5
3,33 m	2	0	2	1	2
	5 m	6	7	5	4
F1 (t)	● 85	86	85	84	82
	■ 114	116	113	108	110
↑ (m) D50	37,2	33,8	32,2	30,5	27,2

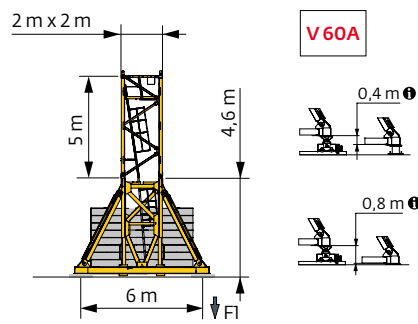
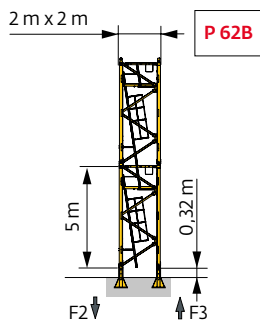

Ancrages / Verankerungen / Anchorages / Anclajes / Ancoraggi  
 Ancoragem / нкeпa



Lest de base / Grundballast / Base ballast / Lastre de base / Zavorra di base  
 Lastro da base / Базовый Балласт

**Σ(t) / [ 1,6 m - S 41A - C50**

Σ(t) (m)	30	35	40	45	50
36,1	108				
32,7	96	102			
31,1	90	102	108		
29,4	90	96	102	114	
26,1	78	84	90	102	108
21,1	72	78	84	90	96
16,1	60	66	72	78	84

**Σ(t) / [ 2 m - V 60A - C50**

Σ(t) (m)	30	35	40	45	50
45,5	132				
43,8	120	132			
40,5	96	120	132		
37,2	84	96	108	132	
35,5	60	84	108	120	132
30,5	60	60	60	84	108
25,5	48	48	60	60	72
20,5	36	48	48	48	60
15,5	36	36	36	48	48

Courbes de charges / Lastkurven / Load curves / Curvas de cargas / Curve di carico  
 Curvas de carga / Кривые нагрузок



Σ(t) (m)	17	20	22	25	27	30	30,2	32	35	35,1	37	40	40,1	42	45	m			
45	8 t		4 t																
45	4,3 → 21,6	33,4 - 34		8	8	7,8	6,5	5,7	4,8	-	4,3	3,8	-	3,4	2,9	-	2,65	2,25	t
40	4,1 → 21,6	33,4 - 34,1		8	8	7,8	6,5	5,7	4,8	-	4,3	3,8	-	3,4	2,95	2,95	t		
35	3,8 → 22,5																		
35	8	8	8	6,9	6,1	5,2	-	4,7	4	4	t								
30	3,5 → 22																		
30	8	8	8	6,6	5,9	5	5	t											

= - 0,14 t max.



Σ(t) (m)	17	20	22	25	27	30	30,2	32	35	35,1	37	40	40,1	42	45	47	50	m		
50	4 t																			
50	4,6 → 35,7		4	4	4	4	4	4	4	4	4	4	3,7	3,2	-	2,95	2,55	2,3	2	t
45	4,3 → 35,3		4	4	4	4	4	4	4	4	4	4	3,7	3,2	-	2,9	2,5	t		
40	4,1 → 35,4		4	4	4	4	4	4	4	4	4	4	3,7	3,2	3,2	t				
35	3,8 → 35,1		4	4	4	4	4	4	4	4	4	t								
30	3,5 → 30,2		4	4	4	4	4	4	4	t										

Poids de flèche & lest de contre-flèche / Auslegergewicht & Gegenauslegerballast / Jib weight & counter-jib ballast  
 Peso de flecha y lastre de contra-flecha / Peso del braccio & zavorra di contro-braccio / Peso da lança & lastro da contra lança  
 Вес стрелы и балласт контр-стрелы

	▲▼▲▲ (kg) (+/- 5%) ② → ⑧		④	▲≡ (kg)
50 m	5845	-	4	19000
45 m	5540	5720	4	19000
40 m	5185	5365	4	19000
35 m	4790	4970	4	19000
30 m	4315	4495	4	19000

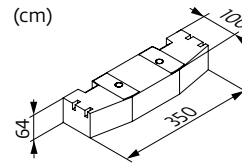

CCL - 4750 kg



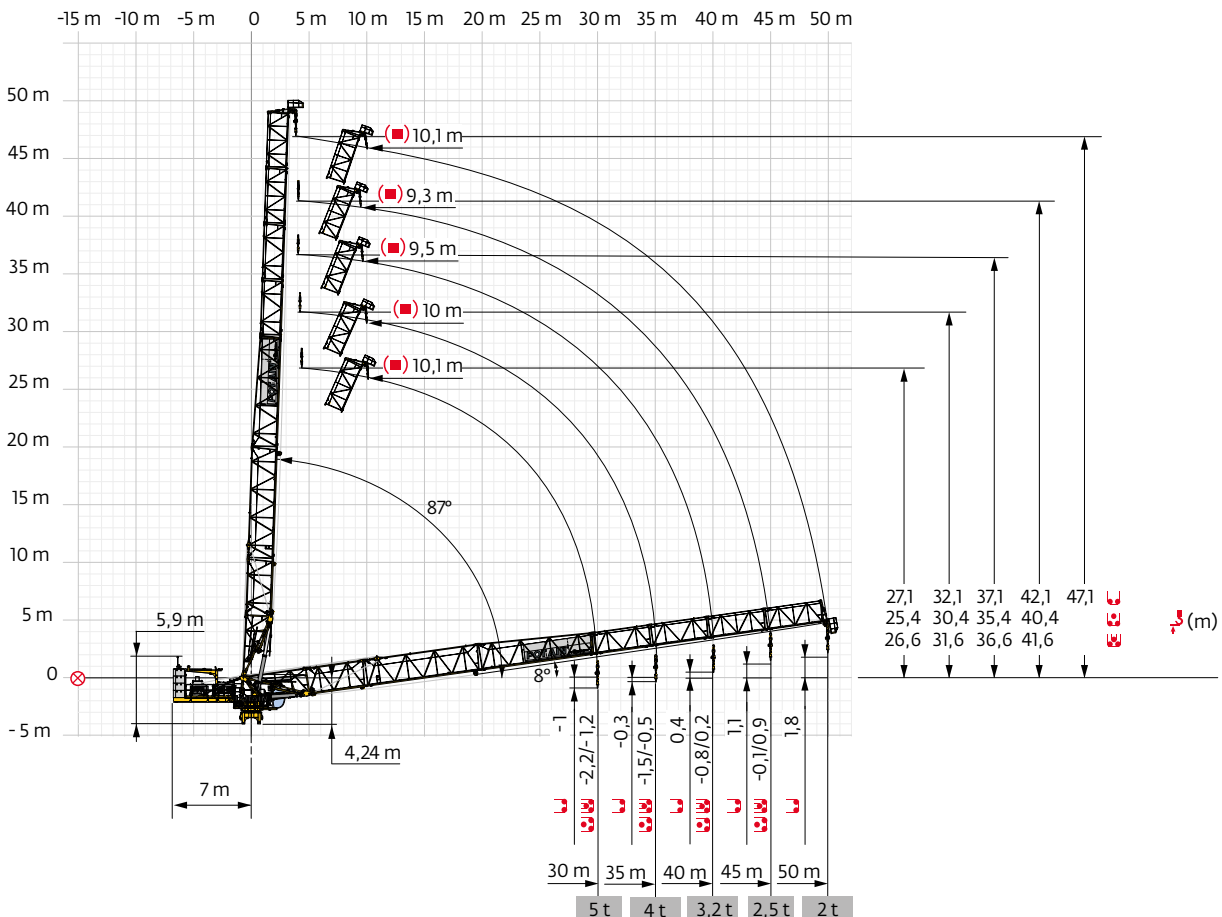





Flèche relevée / Ausleger in Steilstellung / Luffing jib / Flecha izada / Braccio impennato  
 Lança inclinada / Маховая стрела



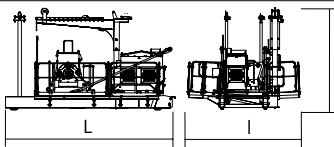
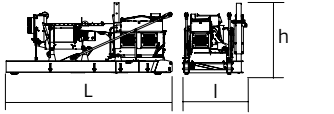
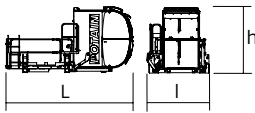
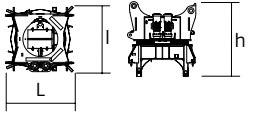
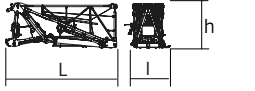
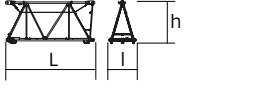
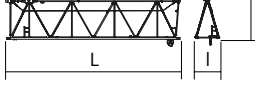

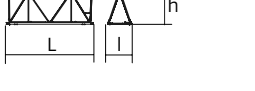
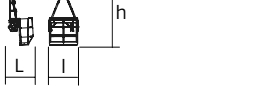
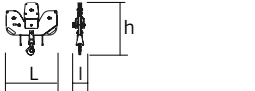
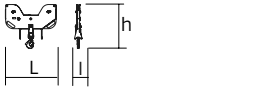
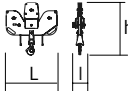
Encombrement et poids / Abmessungen und Gewicht / Dimensions and weight / Dimensiones y peso / Ingombro e peso  
 dimensões e pesos / габаритные размеры и вес

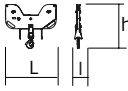
Partie tournante / Drehender Kranteil / Slewing crane part / Parte giratoria  
 Parte rotante / Parte rotativa / Поворотная часть :  50 m -  33 LVF

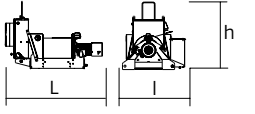

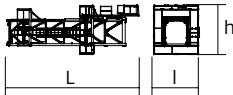
Partie tournante / Drehender Kranteil / Slewing crane part Parte giratoria / Parte rotante / Поворотная часть	L (m)	l (m)	h (m)	kg (+/- 5%)		
Contre-flèche / Gegenausleger Counter-jib / Contra-flecha Controbraccio / Contra-lança Контр-стрела	 h 33 LVF 50 LVF	5,89	3,93	3,53	5770 6230	
	 h 33 LVF 50 LVF	5,79	2,25	2,49	5310 5770	
Cabine / Kabine Cab / Cabina Cabina / Cabina Кабина	 h	V140 SR	4,85	2,37	2,5	1700
Pivot / Krankopf Towerhead / Pivote Portaralla / Pivot Секция поворотной части	 h	□ 1,6 m	2,15	2,06	2,36	4700
		□ 2 m	2,31	2,39	2,36	5765
Elément de flèche / Auslegerelement Jib section / Elemento de flecha Elemento di braccio / Elemento de lança Секция стрелы	 h ①	6,24	2,08	2,56	5900	
	 h ②	5,23	1,59	2,52	985	
	 h ③	10,25	1,44	2,5	1455	
	 h ④	10,21	1,42	2,37	1495	
	 h ⑤	5,17	1,42	1,96	475	
	 h ⑥	5,15	1,39	1,93	395	
	 h ⑦	5,15	1,38	1,92	355	
	 h ⑧	5,15	1,38	1,91	305	
Moufle / Hubflasche Pulley block / Aparejo Bozzello / Cadernal Полиспаст	 h 	1,46	0,36	1,5	380	
	 h 	1,46	0,22	1,25	200	
Treuil de levage (+ câble) / Hubwerk (+ Seil) Hoisting winch (+ rope) / Mecanismo de elevación (+ cabo) Argano di sollevamento (+ fune) Guincho de elevação (+ cabo) Подъемная лебедка (+ канатом)	 h	33 LVF 50 LVF	2,34 2,51	1,53 1,63	1555 2015	

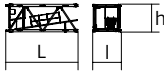
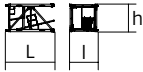
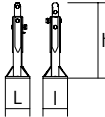
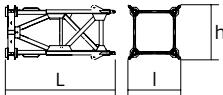
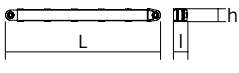
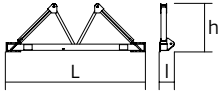
Рулоне / Kranturm / Crane tower Mástil / Torre / Torre Башня крана		L (m)	I (m)	h (m)	kg (+/- 5%)
T41 T61		10,85 10,83	3,73 4,14	4,1 4,47	7100 9700
K 447B K 447E KM 447E KM 449E K 649B KM 649E		10,21 10,21 10,21 10,21 10,23 10,29	1,67 1,62 1,62 1,62 2,07 2,03	1,62 1,62 1,62 1,62 2,03 2,03	3450 3390 3215 3830 5290 4850
K 447A KMT 447A K 449A KMT 449A KR 649A KRMT 649A K 649A KMT 649A		5,21 5,21 5,21 5,21 5,23 5,23 5,23	1,67 1,67 1,67 1,67 2,1 2,1 2,07	1,62 1,62 1,62 1,62 2,08 2,08 2,03	1850 1745 2230 2130 3250 3050 2805 2570
K 447C K 649C KRMT 649C		3,45 3,57 3,57	1,67 2,07 2,1	1,62 2,03 2,08	1360 1985 2450
Pieds de scellement / VerankerungsfüÙe Fixing angles / Pie de empotramiento Montante da annegare / Angulos fixadores анкера		0,37 0,65	0,37 0,65	1,14 1,27	135 295
Mât-châssis / Grundmasteinheit Basic mast unit / Tramo-chasis Elemento base / Tramo-chassis Мачта для крепления к шасси		3,63 5,01	1,96 2,41	2,08 2,41	2965 4390
Haubans / Mastabstützungen Struts / Tornapuntas Puntoni / Escoras Растяжка		3,18 4,51	0,26 0,29	0,24 0,29	220 420
Sommier / Unterwagenhälfte Half-bearer / Testero Testata / Estrutura base Траверса		5,1 6,7	0,6 0,7	1,78 2,31	1145 1600

Mécanismes / Triebwerke / Mechanisms / Mecanismos / Meccanismi  
 Mecanismos / Механизмы

400 V - 50 Hz										ch - PS hp	kW		
	<b>33 LVF 20 Optima</b>	m/min	26	34	50	71	13	17	25	35,5	33	22	469 m
		t	4	3	2	1	8	6	4	2			
	<b>50 LVF 20 Optima</b>	m/min	44	58	82	118	22	29	41	59	50	37	697 m
		t	4	3	2	1	8	6	4	2			
	<b>40 VVH 80</b>	min	2								40	30	
	<b>RVF 152 Optima +</b>	tr/min U/min rpm	0 → 0,8								2 x 5,5	2 x 4	

	<b>IEC 60204-32</b>		<b>kVA</b>
400 V (+10% -10%) 50 Hz		33 LVF : 68 → 55 kVA 50 LVF : 82 kVA	

33 LVF 20 Optima

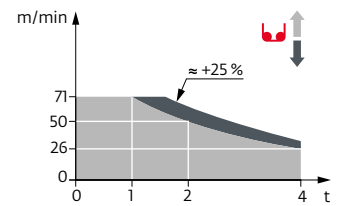

50 LVF 20 Optima

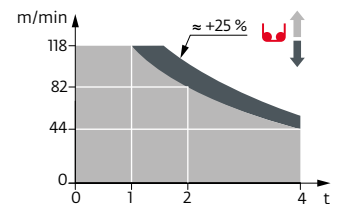

	FR	DE	EN	ES	IT	PT	RU
	Profil de vent suivant EN 14439 C50-D50	Windbedingungen gemäss EN 14439 C50-D50	Wind conditions according to EN 14439 C50-D50	Conformidad de los condiciones de viento EN 14439 C50-D50	Condizioni del vento secondo EN 14439 C50-D50	Perfil de vento conforme EN 14439 C50-D50	Ветровой режим в соответствии с EN 14439 C50-D50
	Equipements standards	Standardausrüstungen	Standard equipment	Equipamiento de serie	Equipaggiamento standard	Equipamento de série	Стандартное оборудование
	Equipements optionnels	Sonderausrüstungen	Options	Equipamiento opcional	Equipaggiamento in opzione	Equipamento opcional	Дополнительное оборудование (опция)
	Réactions en service	Reaktionskräfte in Betrieb	Reactions in service	Reacciones en servicio	Reazioni in servizio	Reacções em serviço	Реакция при работе
	Réactions hors service	Reaktionskräfte außer Betrieb	Reactions out of service	Reacciones fuera de servicio	Reazioni fuori servizio	Reacções fora de serviço	Реакция в покое
	Poids de flèche	Auslegergewicht	Jib weight	Peso de flecha	Peso del braccio	Peso da lança	вес стрелы
	Poids total du lest	Ballast-Gesamtgewicht	Total ballast weight	Peso total del lastre	Peso totale della zavorra	Peso total do lastro	Общий вес балласта
	Axe articulation flèche	Auslegergelenksachse	Jib articulation axis	Eje de articulación de la flecha	Perno di articolazione del braccio	Eixo de articulação da lança	Ось шарнира стрелы
	Position girouette	Windfreistellung	Weathervaning position	Posición veleta	Libera rotazione	Posição em cata-vento	Флюгер
	Camion 13,4 m	Lkw 13,4 m	Lorry 13,4 m	Camión 13,4 m	Camion 13,4 m	Camião 13,4 m	Рзуповой автомобиль 13,4 м
	Conteneur High Cube 40', et/ou Flat Rack 20'	Container High Cube 40', und/oder Flat Rack 20'	Container High Cube 40', and/or Flat Rack 20'	Contenedor High Cube 40', y/o Flat Rack 20'	Container High Cube 40', e/o Flat Rack 20'	Contentor High Cube 40', e/ou Flat Rack 20'	40-футовый контейнер повышенной вместимости High Cube, и/или 20-футовая открытая платформа Flat Rack
	Levage	Heben	Hoisting	Elevación	Sollevamento	Elevação	Подъем
	Relevage	AL-Verstellen	Luffing	Izado	Brandeggio	Levantamento	Маховый подъем
	Orientation	Schwenken	Slewing	Orientación	Rotazione	Rotação	Поворот
	Translation	Kranfahren	Travelling	Traslación	Traslazione	Translação	Перемещение крана
	Puissance requise	Erforderliche Leistung	Required power	Potencia Necesaria	Potenza richiesta	Potência Necessária	Потребляемая мощность
	Fonction Power Control : vitesses treuils adaptées à la puissance disponible	Funktion Power Control : Geschwindigkeiten der Triebwerke werden an die verfügbare Leistung angepasst	Power Control Function: winch speeds adapted to the available power	Función Power Control: marchas de los cabrestantes adaptadas a la potencia disponible	Funzione Power Control: velocità degli argani adattate alla potenza disponibile	Função Power Control: velocidades de guincho adaptadas à potência disponível	Функция контроля мощности Power Control: регулировка скорости лебедок в зависимости от доступной мощности
	Nous consulter	Auf Anfrage	Consult us	Consultarnos	Consultateci	Consultar-nos	Проконсультируйтесь у нас
	Document commercial non contractuel. Pour toute information technique se référer à la notice correspondante.	Unverbindliches Vertriebsdokument. Für technische Informationen, siehe die entsprechenden Anweisungen.	This commercial document is not legally binding. For any technical information, please refer to the corresponding instructions.	Documento comercial no contractual. Para cualquier información técnica, ver la noticia correspondiente.	Documento commerciale non vincolante, per tutte le informazioni tecniche fare riferimento al catalogo istruzioni.	Documento comercial não contratual. Para qualquer informação técnica complementar consultar as respectivas instruções.	Этот коммерческий документ не является юридически обязательным. Для получения технической информации, см. соответствующие инструкции.

