

The Packo pumps of the ICP2 series are mainly used as a process pump for pumping clean as well as slightly contaminated liquids. These robust pumps have stainless steel 316L pump casings constructed in thick cold rolled plate and have open investment cast impellers in stainless steel 316L or duplex materials. Thanks to its solid construction and electro polished design these pumps are the reliable component for your production process.



### Application areas

The Packo pumps of the series ICP2 are used in a wide range of industries and applications. You can find them in just about all industries such as vegetable industry, breweries, water treatment and textile industry as well as in e.g. biogas, biodiesel and bioethanol applications.

Typical liquids: blanching water, mash, wort, process and contaminated water, biodiesel, bioethanol, alcohols, CIP, biogas, etc.

### Your benefits

- High pump efficiency resulting in lower energy consumption
- Low NPSH values: less risk on cavitation
- Electropolished
- Easy construction and easy maintenance: Less downtime
- Standard components
- Easy to install
- 2 mechanical seal diameters for the entire range
- Robust construction

### Technical specifications

Max. flow rate	110 m <sup>3</sup> /h
Max. differential head	110 m
Max. liquid viscosity	500 cP
Max. temperature	140°C
Impeller type	Open
Max. free passage	22 mm
Max. motor power	45 kW
Max. speed	3000 / 3600 rpm
Available frequency	50 / 60 Hz
Connections	BSP thread, industrial flanges acc. to EN 1092-1/01 and ANSI (optional: hygienic fittings)
Materials wetted parts	Stainless steel 316L or similar
Available materials o-ring	EPDM, FKM, FEP-FKM, FFKM, Silicone
Mechanical seal configuration	Single, quench, double
Surface finish	Industrial finish: welds are not hand polished. Final surface treatment: electropolished
Certificates & Legislation	1935/2004 EC, FDA, ATEX, EU N° 547/2012



### Performance curves at 2900 rpm

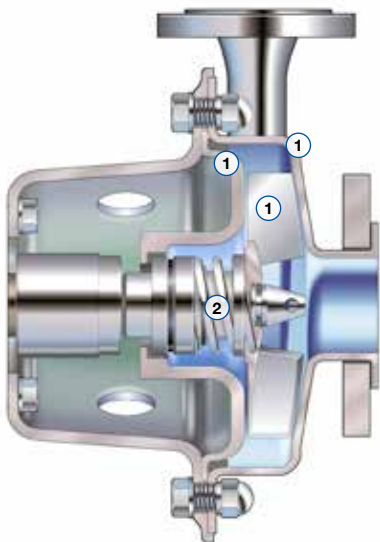
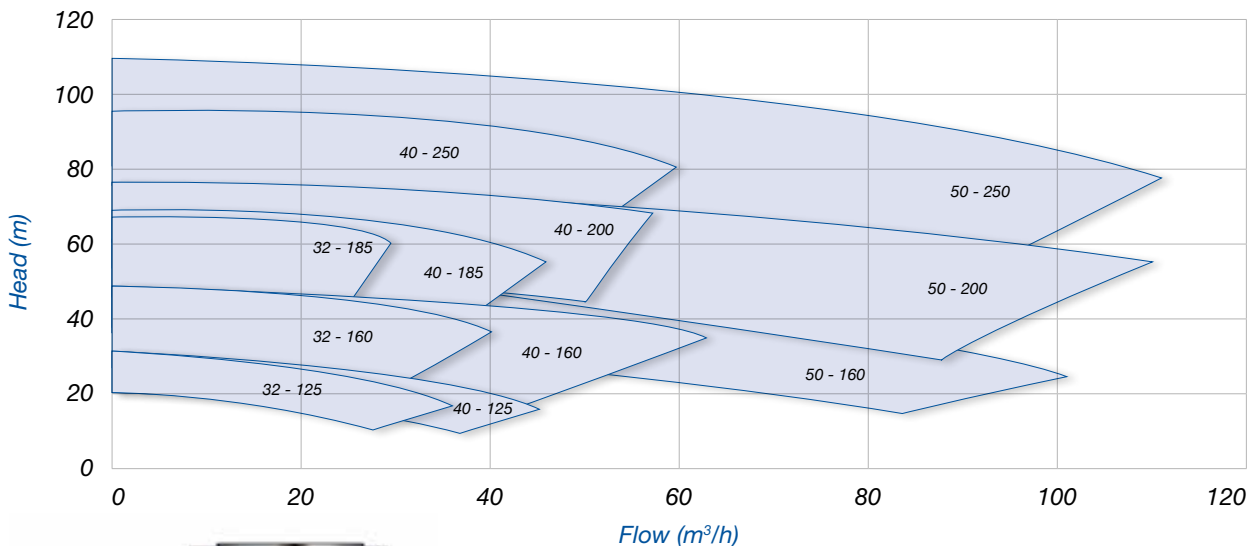

### Specifications

- Solid design thanks to thick pressed casings and investment cast impellers (1)
- Standardized mechanical seals to EN 12756
- FDA approved bellow seals; balanced O-ring seals (2)
- 2 mechanical seal diameters (33 mm up to 22 kW, 43 mm for larger motor powers)
- Use of standardized components
- Electropolished design (for wetted & non-wetted parts); easy to clean and increased corrosion resistance



Electropolished

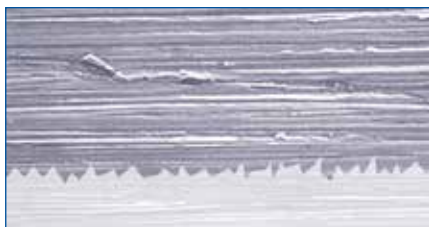

Mechanical polishing 240 grit

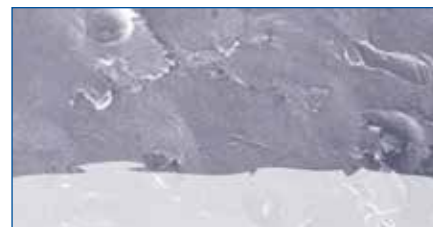

Glass bead blasted

ICP2\_Industrial\_pump\_series\_Technosheet\_rev01\_2016\_(eu)



Find your local supplier at [www.verder-liquids.com](http://www.verder-liquids.com)

For construction, installation and floor mounting drawings please contact your local authorised Verder® distributor.