

GTC-800**MACHINE WEIGHTS**

STANDARD CRANE with 5 section - 43 m boom, full counterweight, 2 winches with wire rope, auxiliary nose sheave and 800 mm 3-bar semi grouser track shoes	79,302 kg
STANDARD CRANE with 5 section - 43 m boom, auxiliary winch with wire rope and 800 mm 3-bar semi grouser track shoes (Counterweight removed)	49,819 kg
STANDARD CRANE with auxiliary winch with wire rope (Counterweight and track frames removed; with Carbody Jacks)	33,956 kg
Counterweight 6.8 t (Configuration A)	6,804 kg
Counterweight 6.8 t (Configuration B)	6,804 kg
Counterweight 1.7 t x 4 (Configuration C)	6,804 kg
Heavy Lift Jib - 2.5 m	440 kg
Jib Base - 10.1 m	919 kg
Jib Tip - 7.5 m	339 kg
Auxiliary Nose Sheave	48 kg
80 t hook block - six sheave	636 kg
50 t hook block - three sheave	462 kg
20 t hook block - one sheave	296 kg
8 t Overhaul Ball	133 kg
Carbody Jacks	1,485 kg
Track Frame with 800 mm 3-bar semi-grouser track shoe	8,494 kg
Track Frame with 800 mm flat steel track shoe	9,124 kg

GTC-600**MACHINE WEIGHTS**

STANDARD CRANE with 4 section - 38 m boom, full counterweight, 2 winches with wire rope, auxiliary nose sheave and 800 mm 3-bar semi grouser track shoes	61,606 kg
STANDARD CRANE with 4 section - 38 m boom, 2 winches with wire rope, auxiliary nose sheave and 800 mm 3-bar semi grouser track shoes, (Counterweight removed)	41,998 kg
Counterweight 6.8 t (Configuration A)	6,804 kg
Counterweight 6.8 t (Configuration B)	6,804 kg
Heavy Lift Jib - 2.5 m	440 kg
Jib Base - 10.1 m	919 kg
Jib Tip - 7.5 m	339 kg
Auxiliary Nose Sheave	48 kg
60 t hook block - six sheave	543 kg
50 t hook block - three sheave	462 kg
20 t hook block - one sheave	296 kg
8 t Overhaul Ball	133 kg



TADANO MANTIS Corporation
 1705 Columbia Avenue, Franklin, Tennessee 37064, U.S.A.
 Phone: +1-800-272-3325 Fax: +1-615-790-6803
<http://www.mantiscranes.com/> E-mail: sales@mantiscranes.com

TADANO FAUN GmbH
 Faunberg 2 · 91207 Lauf a. d. Pegnitz · Germany
 Phone: +49-9123-185-0 · Fax: +49-9123-3085
www.tadanofaun.de · info@tadanofaun.de

GTC-800/600-1-E-17-9-02-83-537-A
 Printed in Japan



Lifting your dreams

TELESCOPIC BOOM CRAWLER CRANE

GTC-800 GTC-600

80 METRIC TON CAPACITY

60 METRIC TON CAPACITY



*The GTC-800/600:
 High Quality We Are Proud Of*



MULTI PURPOSE CRANES: LIFTING AND FOUNDATION WORK

*Most practical cranes
for your job site!*

Crane capacity
80 t

Crane capacity
60 t



GTC-800

GTC-600

Assist Cylinders for Jib

When mounting and stowing the fly jib, two assist hydraulic cylinders ensure safe and efficient operation.



Jib Interlock System

Interlock jib pinning system ensures safer and quicker jib mounting and stowing procedure.

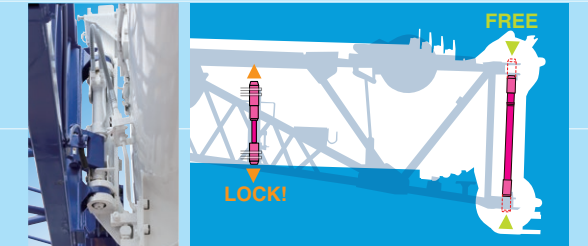

The pivot pin that holds the jib to the boom is part of the interlocking system.

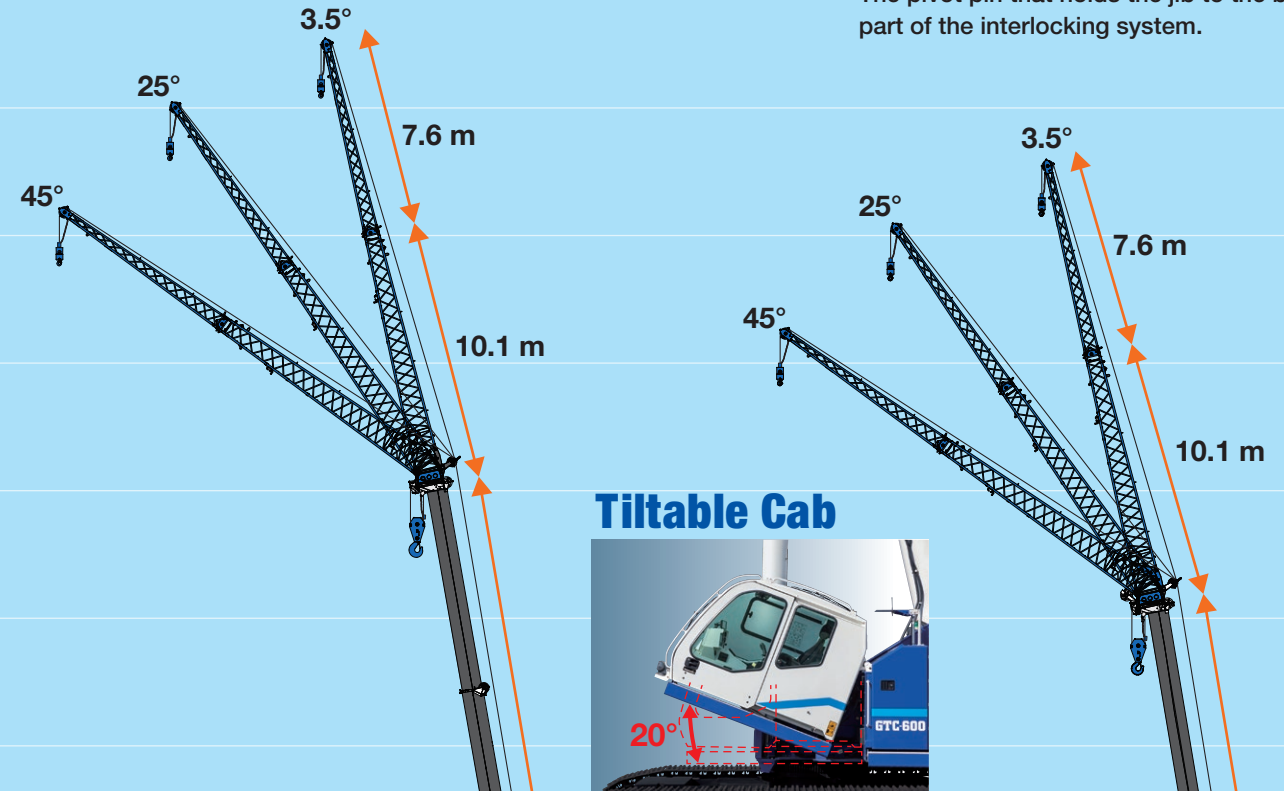

GTC-800

Crane capacity: 80 t at 3.0 m
Main boom: 5-section,
11.5 m - 43.0 m
Main jib: 10.1 m
Fly jib: 17.7 m
Maximum lifting height:
42.1 m (Main boom)
52.9 m (Main boom + Main jib)
60.4 m (Main boom + Fly jib)
Maximum load radius:
40.0 m (Main boom)
50.0 m (Main boom + Main jib)
55.0 m (Main boom + Fly jib)

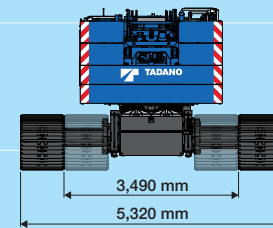

11.5 m -
43.0 m

GTC-600

Crane capacity: 60 t at 3.0 m
Main boom: 4-section,
11.5 m - 38.0 m
Main jib: 10.1 m
Fly jib: 17.7 m
Maximum lifting height:
38.2 m (Main boom)
47.6 m (Main boom + Main jib)
55.5 m (Main boom + Fly jib)
Maximum load radius:
32.0 m (Main boom)
40.0 m (Main boom + Main jib)
45.0 m (Main boom + Fly jib)

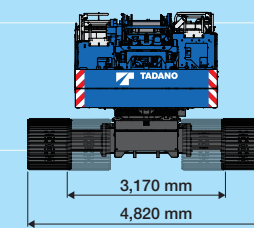

11.5 m -
38.0 m

80 m
75 m
70 m
65 m
60 m
55 m
50 m
45 m
40 m
35 m
30 m
25 m
20 m
15 m
10 m
5 m

BENEFITS OF TELESCOPIC BOOM CRAWLER CRANES

Quick & Safer Set Up

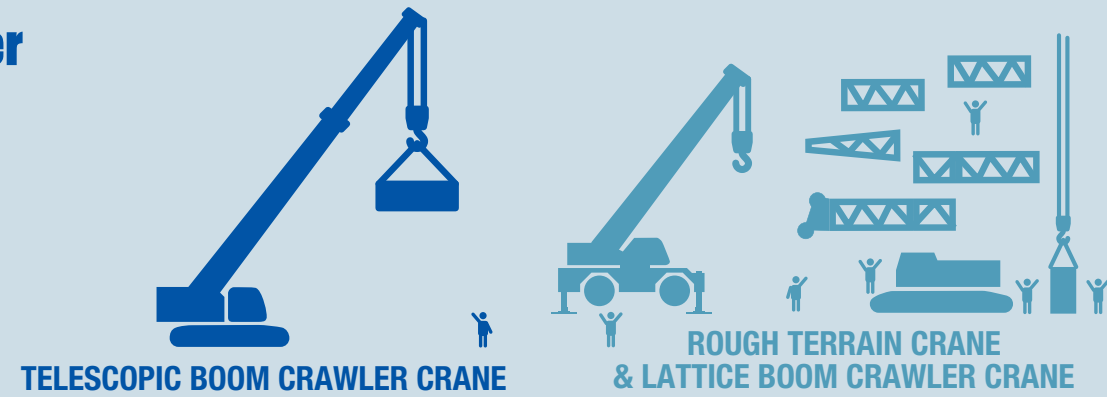

Maximum Pick & Carry Capacity at 360°

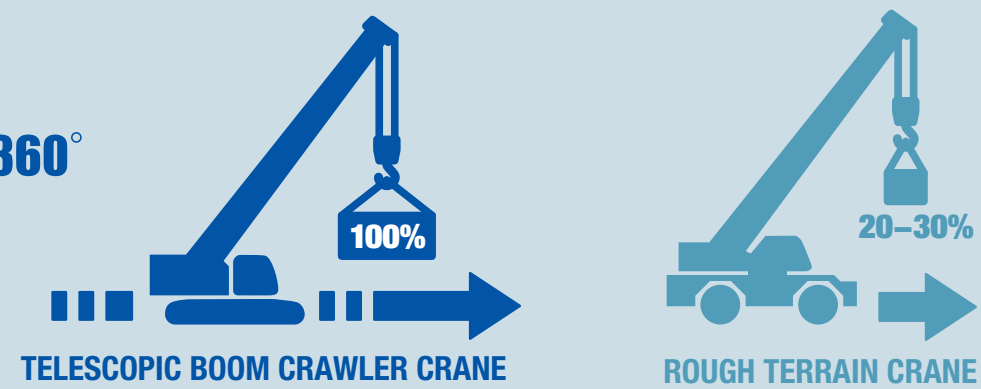

Compact Work Dimension Low Ground Bearing Pressure

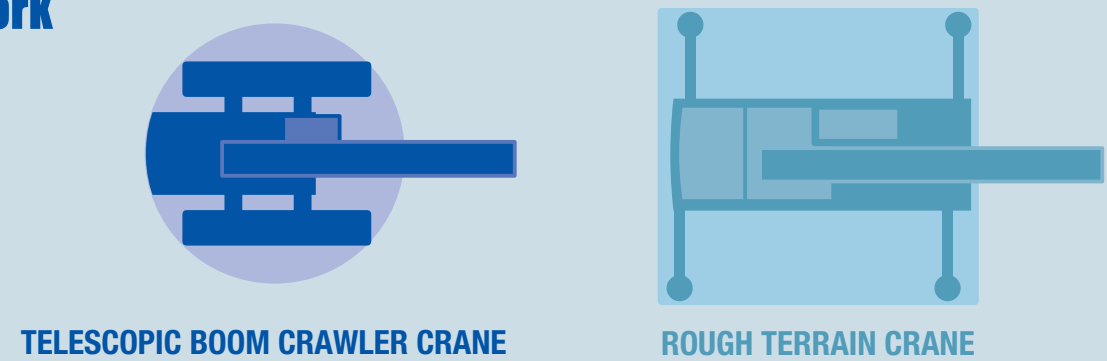

Less Transportation Costs

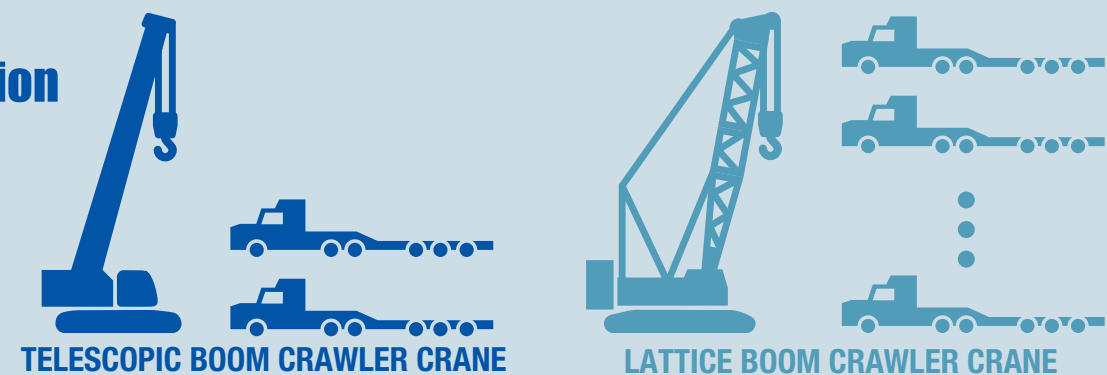

GENUINE PICK & CARRY DESIGN

Level ground load charts available up to 1.5° slope!
Load chart at 4° slope is top in class!

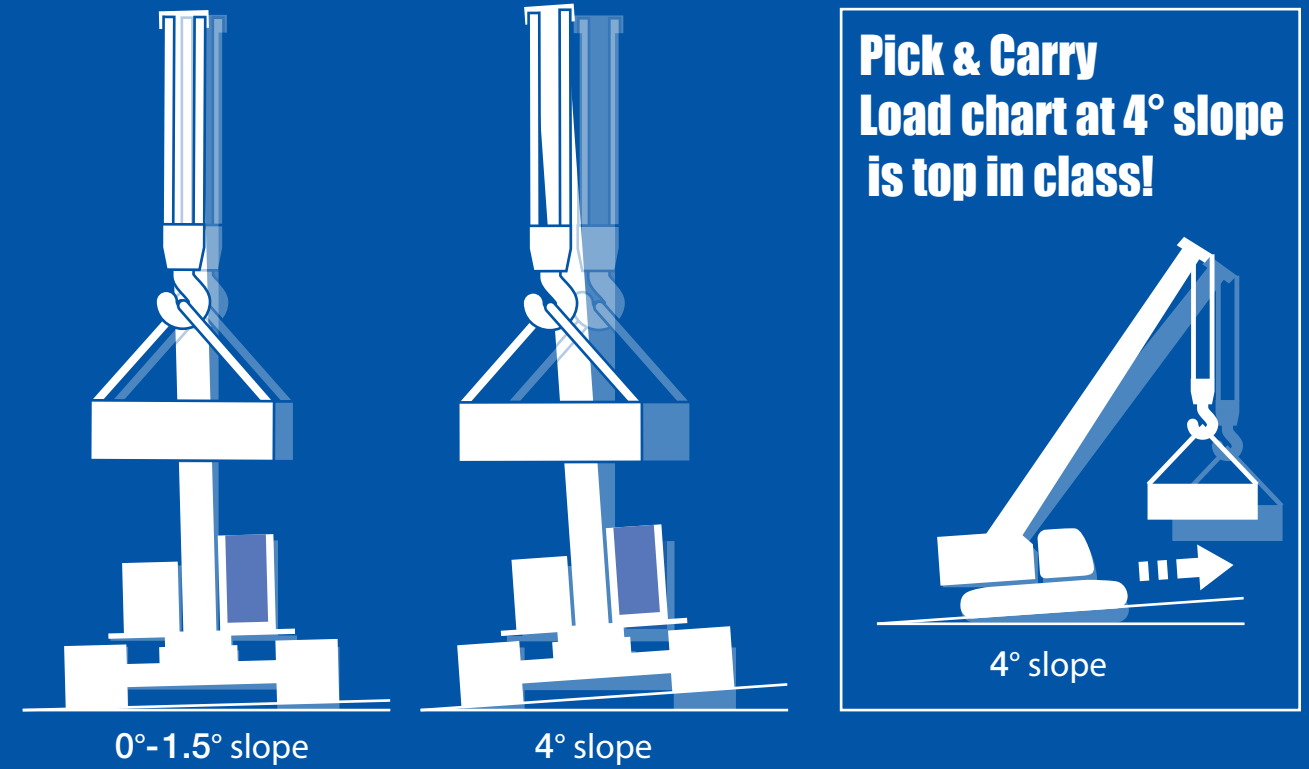

Even at 4° slope the GTC maintains 85% of level ground capacity!

*When tracks fully extended

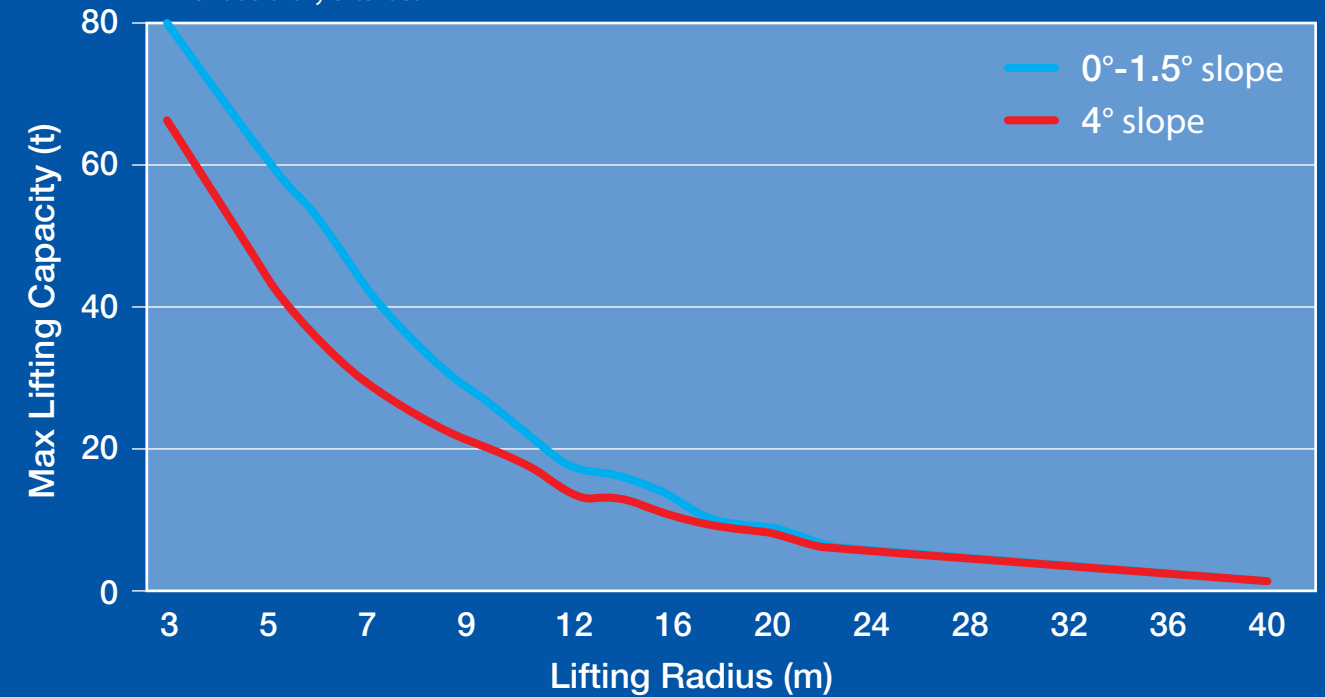

New Features

Retains all of the beneficial features of the GTC Series

- Pick & Carry the load on uneven and rough terrain around 360 degrees slew conditions
- Pick & Carry the load with track retracted position*
- Telescope under full load lifting capacity
- Automatic switching load charts for operation up to 4 degrees out of level
- Use of foundation attachments such as vibratory hammer**

*Counterweight needs to be installed.

**TADANO MANTIS Guidelines for vibratory hammer use must be followed.

Quality

The GTC series cranes utilize the best designs from Tadano engineers around the world to improve performance, quality and reliability. Incorporating such components as winches, jibs, and boom elevating cylinders from Tadano Japan.

Long Boom and Enhanced Lifting Capacity

The GTC booms are purpose designed and manufactured for telescopic boom crawlers by Tadano Japan.

Multi Cylinder Boom System

Boom system consists of multi double acting hydraulic cylinders

Two powerful winches

Grooved drums, cable followers and 3rd wrap shutdown are standard.

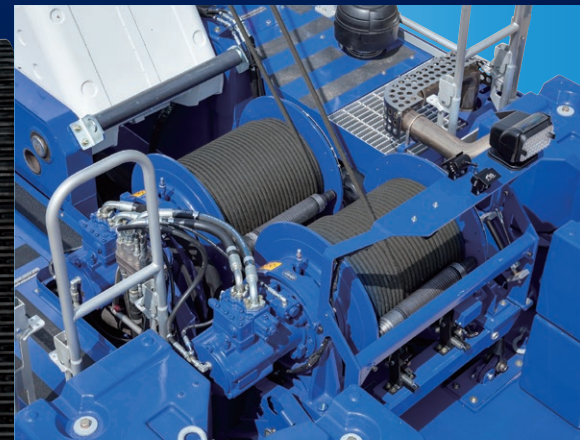

Tough & Durable Design

Simple control system. Class exceeding larger boom sections and boom head, stronger telescopic cylinder.

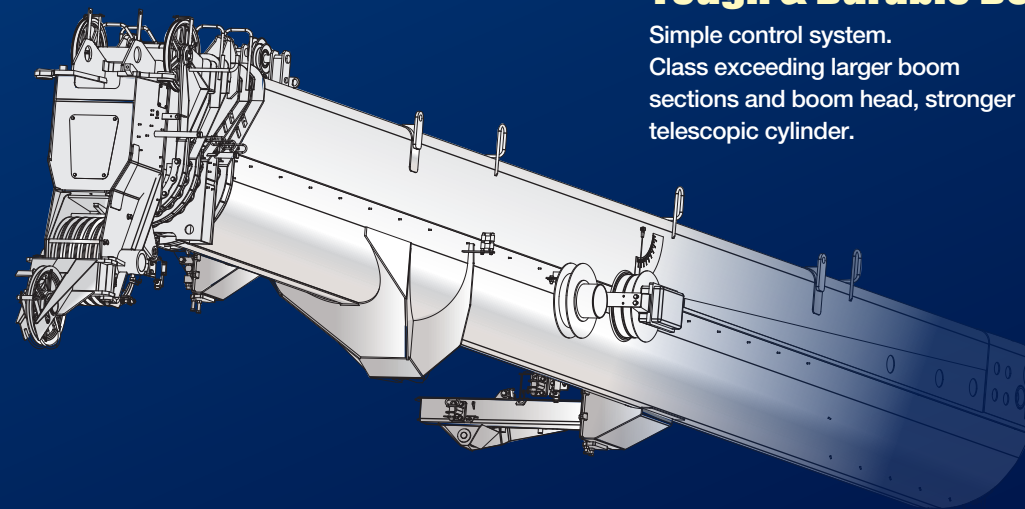

Track frame

Purpose design track frame design incorporating full use of FEM analysis ensuring high rigidity.

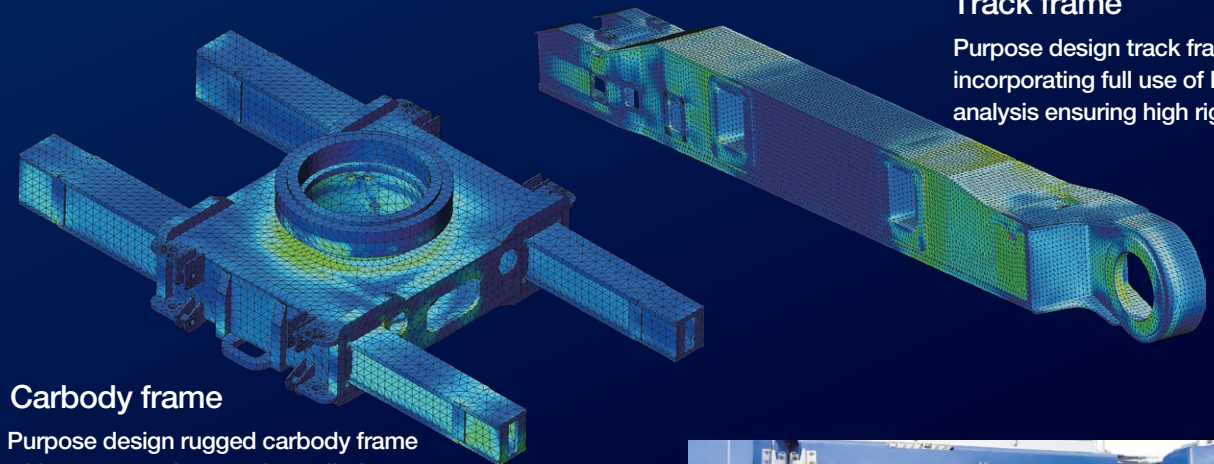

Carbody frame

Purpose design rugged carbody frame with strong track extension cylinders.

High power engine provides superior travel and multi-function performance

Powerful engine, pump and track drive motor.

Crane Engine : 6-cylinder cummins QSB 6.7

• Tier4f, Euromot stage IV
(231kW at 2,200 rpm, max. torque 1,044 Nm at 1,500 rpm)



PRODUCT FEATURES

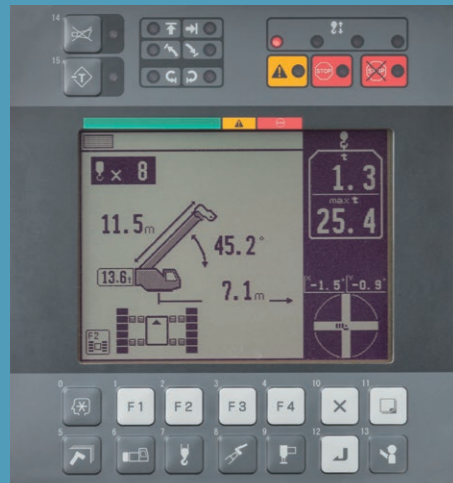

Load Moment Indicator [AML-C]

AML-C allows the operator to simultaneously monitor: boom angle, boom length, crane inclination angle, track extension width, counterweight configuration, rated lifting capacity and hook load. While traveling under load, the crane inclination can be displayed and the AML-C provides the corresponding rated lifting based on actual inclination.

The operator configurable work range limit function warns the operator and provides function soft stop when the crane approaches the pre-registered boom angle (upper limit, lower limit), lifting height, load radius and swing angle.



AML lamp

OPTI-WIDTH OPTIMUM lifting performance at any track WIDTH!

Optimized lifting performance for reduced width configurations. Reduced width, asymmetric track setup can give significant capacity improvements when compared to symmetrical track width settings.

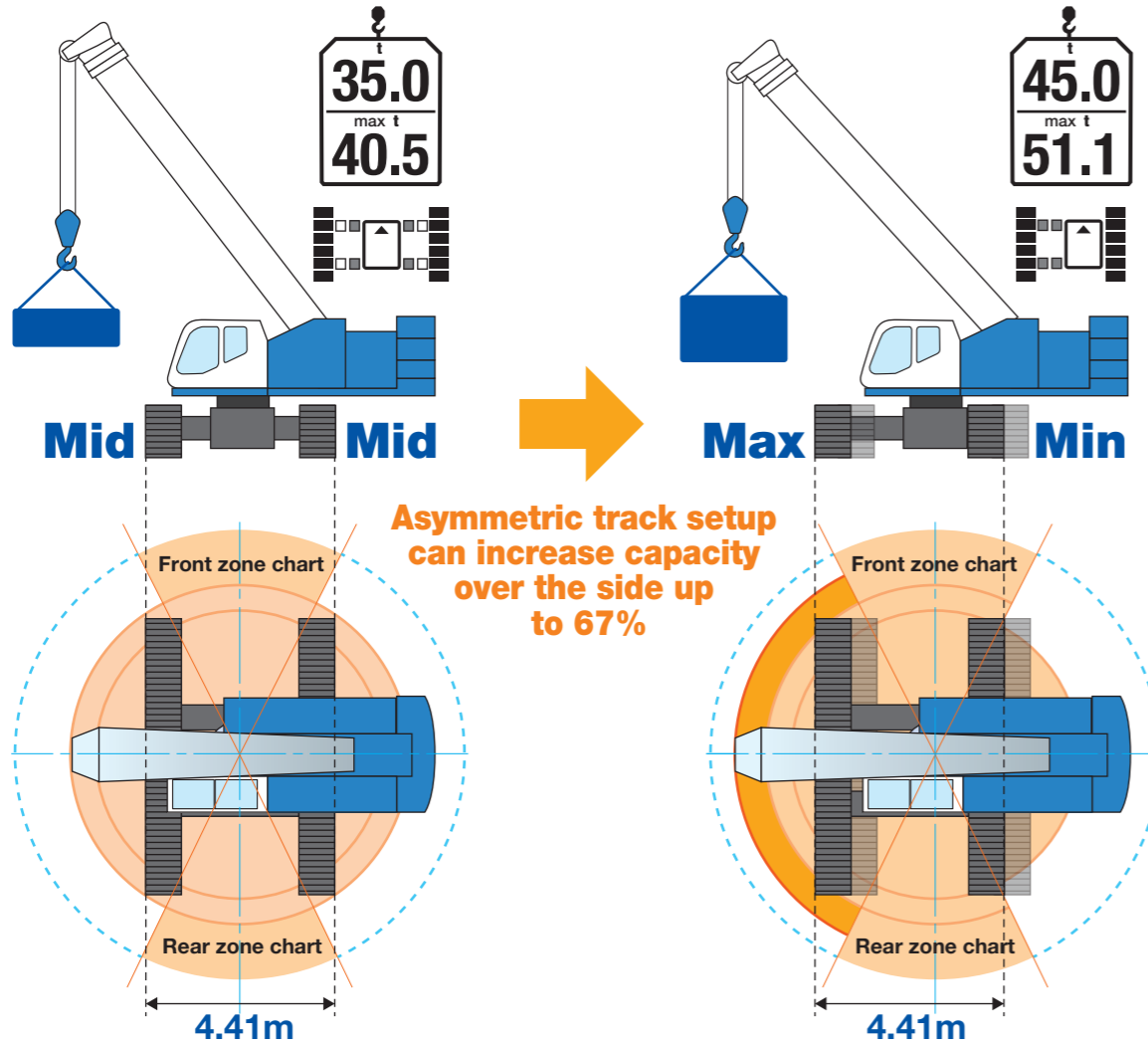

Winch, Rear and Side View Color Monitor (1)



Winch page, monitor display



Load Moment Indicator [AML-C] (2)



Maintenance Reminder Function (3)



Operator can preset the maintenance reminder function on the control screen by selecting the required maintenance items and engine hours from 50 hours up to 2,000 hours.

Travel Mode (4)

Select travel mode by either using the touch screen or pushing a button on the control screen, right joystick acts as a travel controller for improved operability.

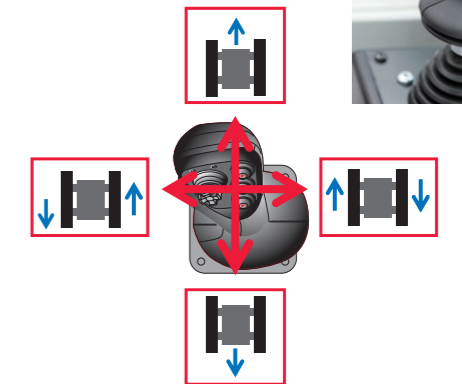

Photo: GTC-600

Wide Steps and Foldable Handrails



Wide Access Walkways



3 Rotation Work Lights



Steel Flat Shoes *optional



Self-removable counterweight

Counterweight can be hydraulically installed/removed by operating remote controller without the need of a support crane.



Three counterweight configurations can be selected.

GTC-800: A, B, C
GTC-600: A, B

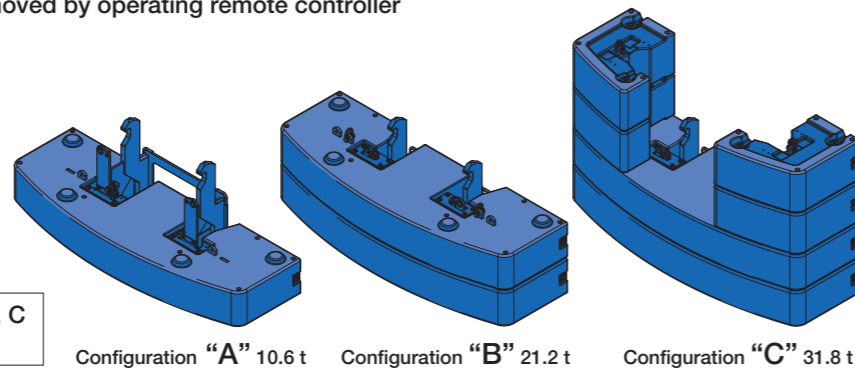

Remote Controller
Counterweight, carbody jack, assist cylinders for jib

Easy Track Frame Removal Self Erect System

Track frames and track extend beams can be easily unlocked and locked without the need of tools or heavy lifting by our patented system.

(*Optional: GTC-800 only)

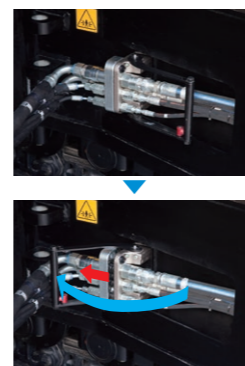
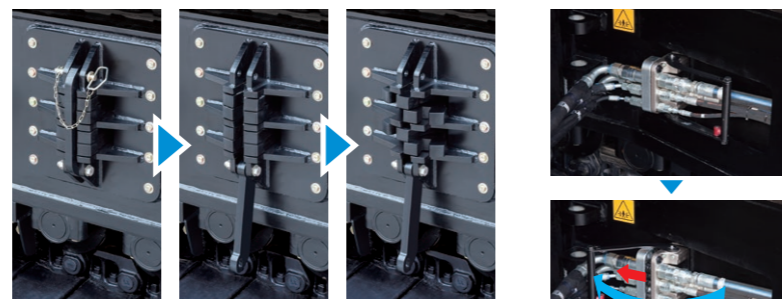

Hydraulic quick coupling system for track motor hydraulic connections

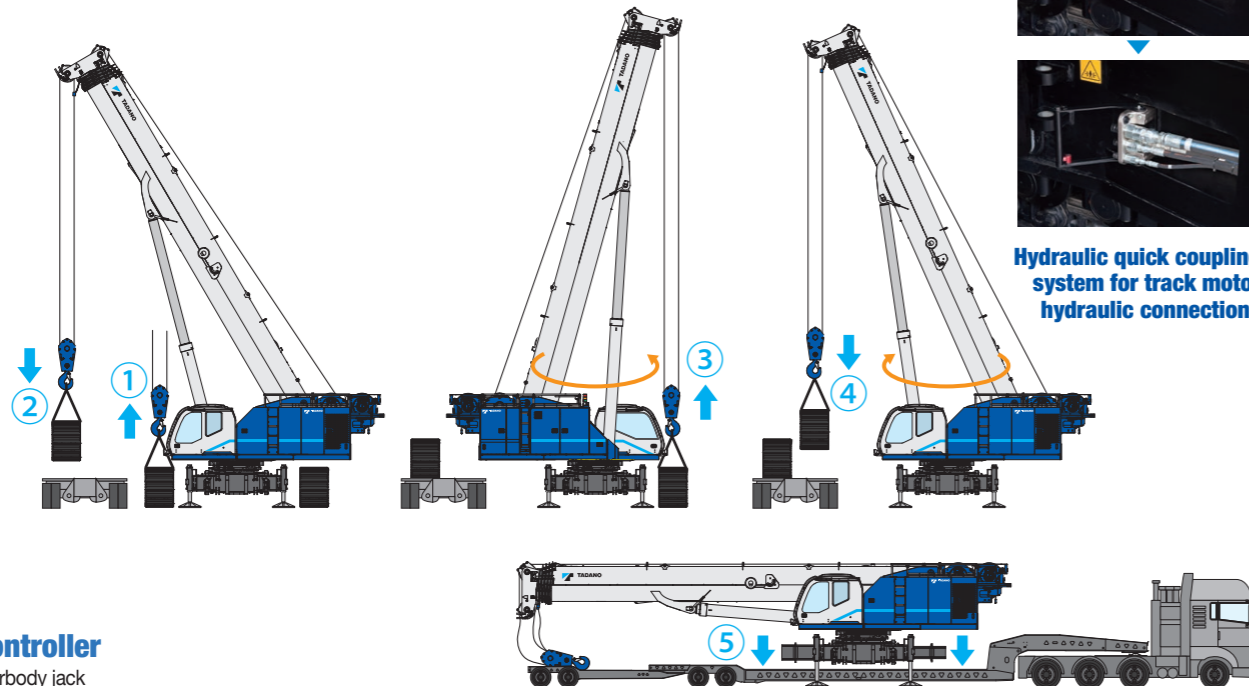

Remote Controller
Track beams, carbody jack

Telematics with HELLO-NET System

HELLO-NET System is an Internet-based crane management system capable of simultaneously monitoring crane location and operating conditions. Service areas differ according to individual countries.

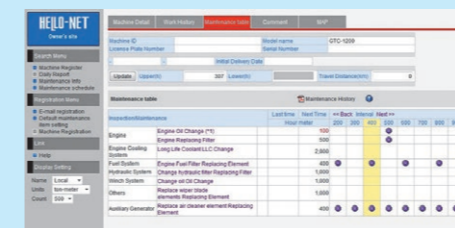
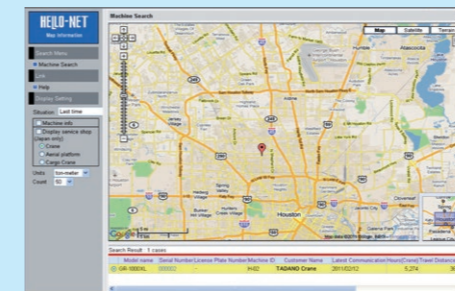
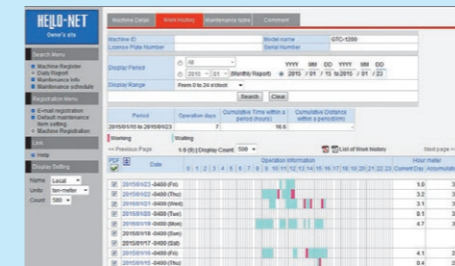

Monitoring machine information from your computer

1. Work History

HELLO-NET Owner's Site displays the day-to-day operational status, mileage and remaining fuel for each machine equipped with a communication terminal. In addition, you can view a list displaying the number of hours of operation and the mileage of all your machines for any specified month.

2. Machine Position Data

Using HELLO-NET Owner's Site, you can check a machine's latest position (up until the previous day) on a map. Two types of position data are transmitted automatically from your machine once a day. Work Site: The location where the machine engine has been activated (for one hour or more). Position at Day's End: The final location data from the GPS which was received on a given day.

3. Maintenance Information

You can check the maintenance timetable of your machines for periodical replacement parts and inspection schedule. HELLO-NET supports the maintenance of your machine.

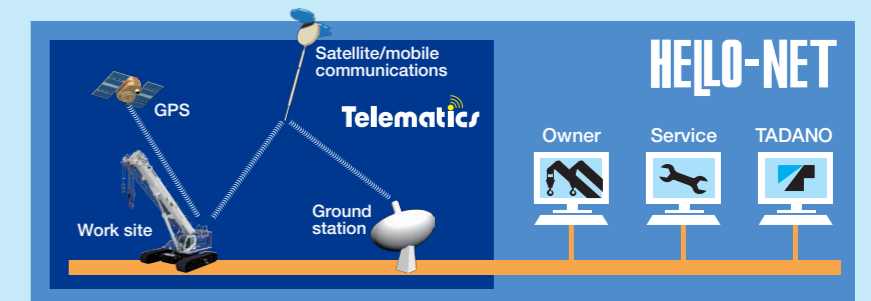

Telematics (machine data logging and monitoring system) with HELLO-NET via internet (*availability depends on countries).

Details: The availability of data communications systems, such as satellite or mobile communications differ according to individual countries. There are some countries where the system itself is not in use. For details, please contact your distributor or our sales staff.

3D Lift Plan*

Customize 3D lift simulation at your fingertips for FREE**. Easy access and user friendly webpage allows you to calculate crane configurations and ground bearing pressure simultaneously. Moreover, you can print out detailed configurations and 3D graphics to further support your work preparation.

*3D Lift Plan is a product of A1A Software LLC.
**Advanced customize functions will be extra.

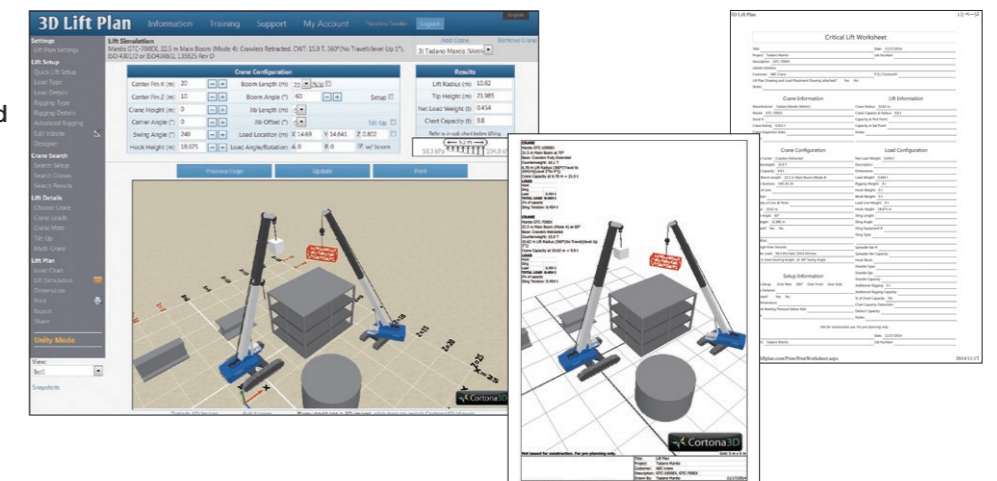

WORK APPLICATIONS

Powerline Transmission & Construction



Foundation & Foundation Support

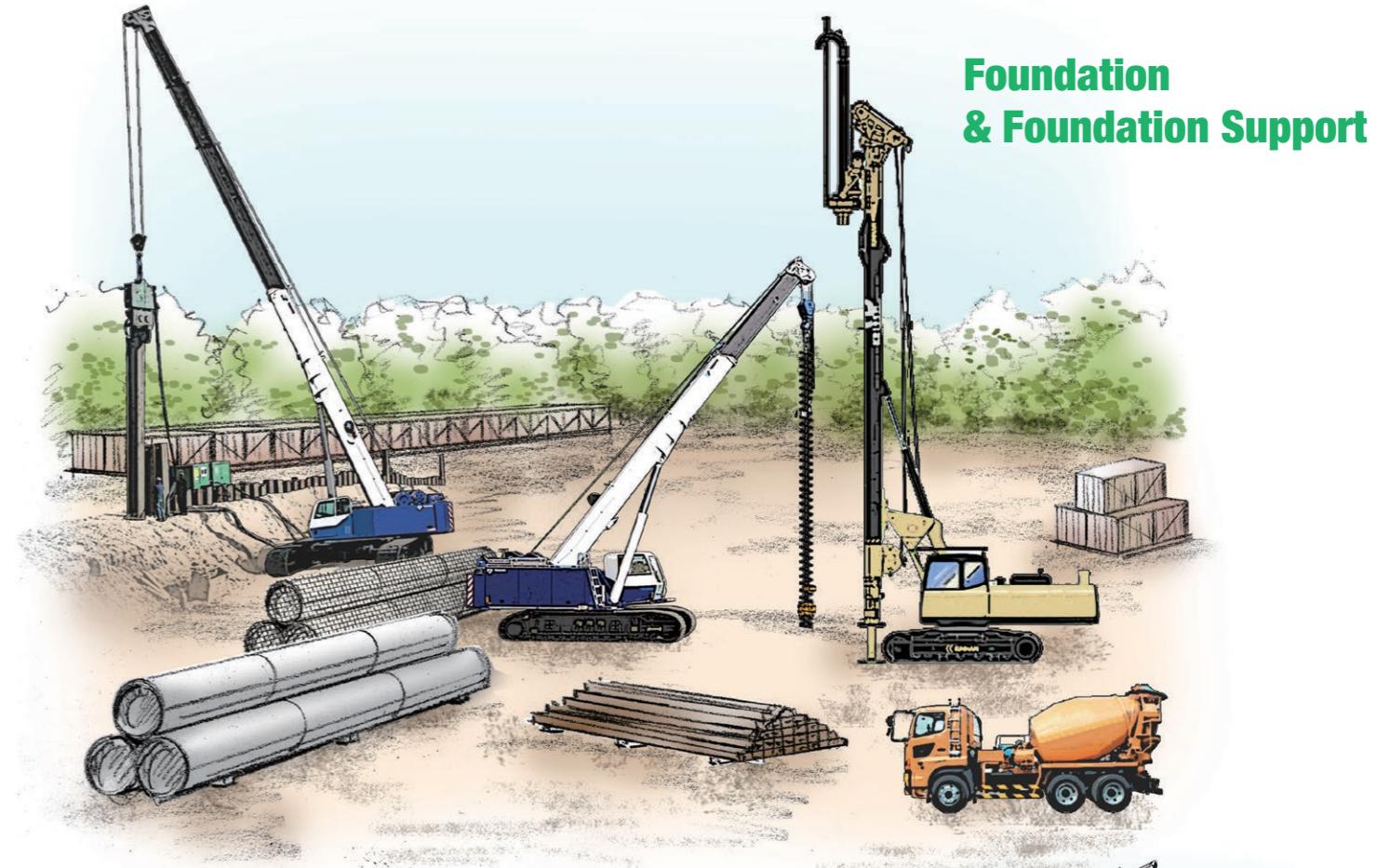

Powerline Utility

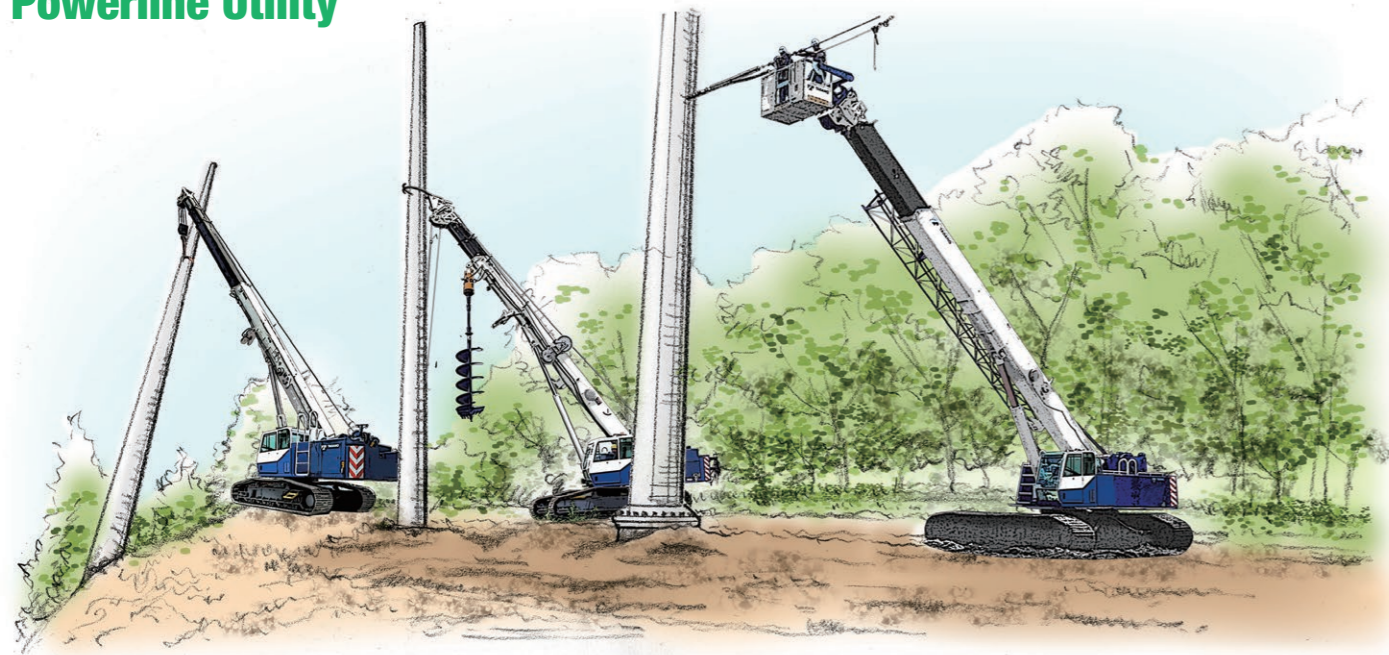

Mining

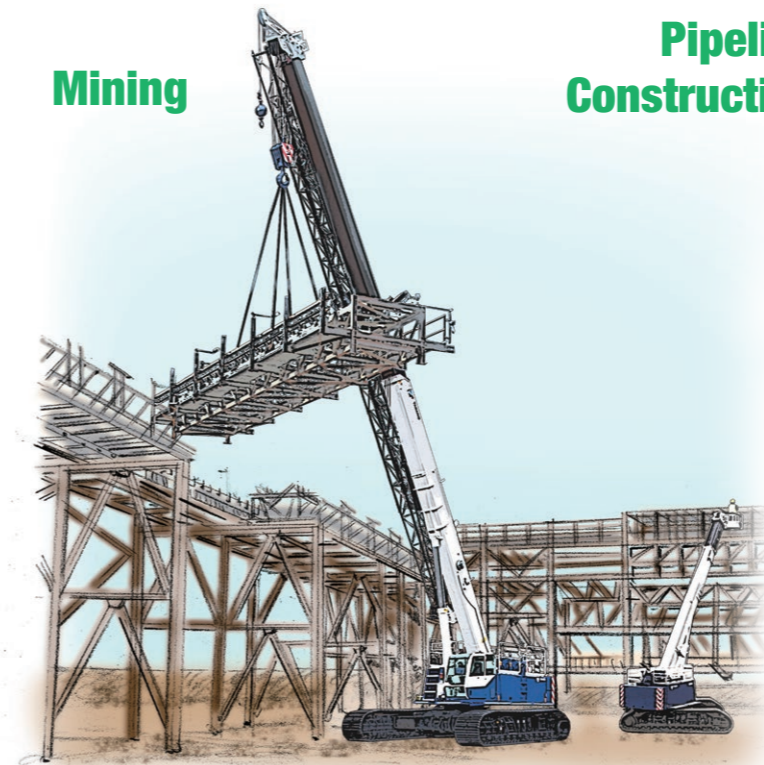

Pipeline Construction

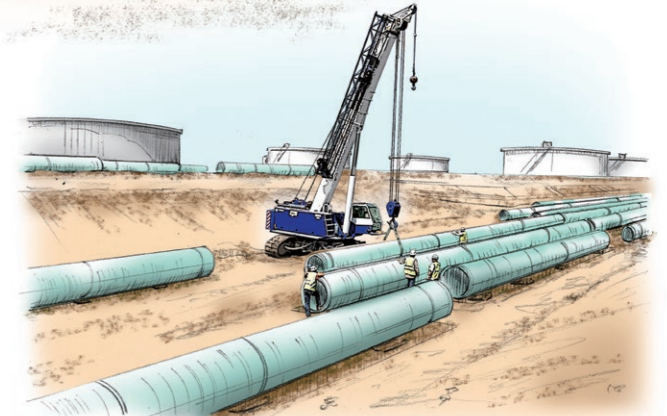

General Construction

