

Fiche technique :

150 AETJ-L BI



Capacities		Métrique	Impérial
Working height	h21	15.4 m	50 ft 6 in
Platform height*	h7	13.4 m	44 ft
Max. outreach	l4	7.81 m	25 ft 7 in
Overhang	l5	7.27 m	23 ft 10 in
Pendular arm rotation (bottom)		-70 °	-70 °
Platform capacity	Q	230 kg	507 lbs
Turret rotation		355 °	355 °
Platform rotation (right / left)		70 ° / 70 °	70 ° / 70 °
Number of people (inside / outside)		2 / 2	2 / 2
Weight and dimensions			
Platform weight*		6435 kg	14187 lbs
Platform dimensions (length x width)	lp / ep	1.2 m x 0.92 m	3 ft 11 in x 3 ft
Overall width	b1	1.91 m	6 ft 3 in
Overall length	l1	6.11 m	20 ft 1 in
Overall height	h17	2.095 m	6 ft 10 in
Overall length (stowed)	l9	4.55 m	14 ft 11 in
Overall height (stowed)	h18	2.13 m	7 ft
Floor height (access)	h20	0.4 m	1 ft 4 in
Jib length	l13	1.26 m	4 ft 2 in
Counterweight offset (turret at 90°)	a7	0 m	0 in
Internal turning radius (over tyres)	b13	1.88 m	6 ft 2 in
Outer turning radius	Wa3	4.27 m	14 ft
Tailswing		0 m	0 in
Ground clearance at centre of wheelbase	m2	0.185 m	7 in
Wheelbase	y	2.2 m	7 ft 3 in
Performances			
Drive speed - stowed		6 km/h	3.7 mph
Drive speed - raised		0.6 km/h	0.4 mph
Gradeability		23 %	23 %
Permissible leveling		5 °	5 °
Wheels			
Tyres type		Foam Filled Non Marking	Foam Filled Non Marking
Dimensions of front wheels		0,65x0,25m	0,65x0,25m
Drive wheels (front / rear)		0 / 2	0 / 2
Steering wheels (front / rear)		2 / 0	2 / 0
Braking wheels (front / rear)		0 / 2	0 / 2
Engine			
Electric engine power rating		4.5 kW	4.5 kW
Electric Pump		3.7 kW	3.7 kW
I.C. Engine power rating / Power (kW)		12.1 Hp / 9.2 kW	12.1 Hp / 9.2 kW
Battery / Batteries capacity		48 V / 300 A	48 V / 300 A
Integrated charger (V / Ah)		48 V / 45 A	48 V / 45 A
Miscellaneous			
Ground Pressure		12.73 daN/cm ²	12.73 daN/cm ²
Hydraulic Pressure		200 Bar	14 PSI
Hydraulic tank capacity		12 l	2.64 gal
Fuel tank		30 l	6.6 gal
Vibration on hands/arms		2.5 Nm	8.2 ft/s
Standards compliance			
This machine is in compliance with:		European directives: 2006/42/EC- Machinery (revised EN280:2013) - 2004/108/EC (EMC) - 2006/95/EC (Low voltage)	European directives: 2006/42/EC- Machinery (revised EN280:2013) - 2004/108/EC (EMC) - 2006/95/EC (Low voltage)

Abaques

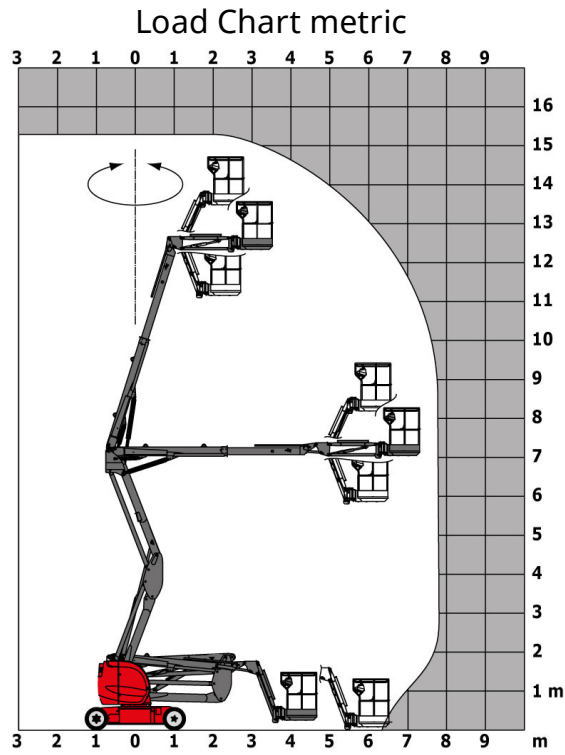

Schémas d'encombrement

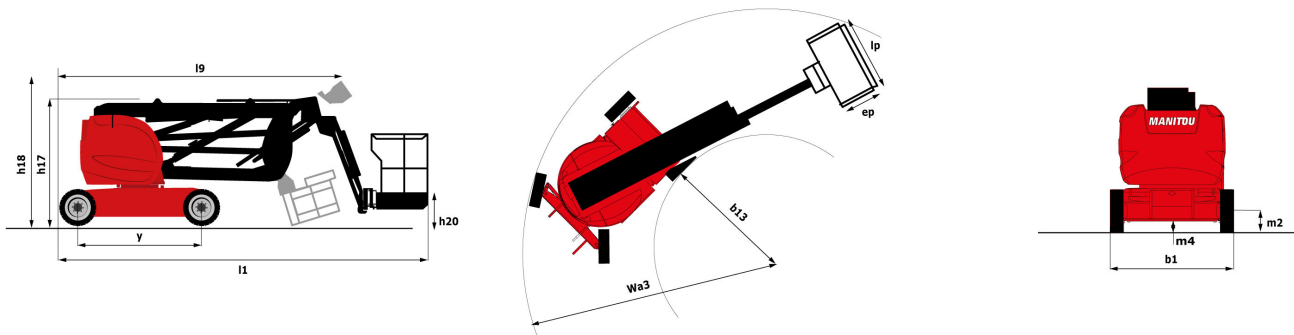

Équipements

Standard

- 230V Predisposition
- All-terrain, non-marking, foam-filled tyres
- Audible alarm and illuminated indicator lamp (leveling, overload, lowering)
- Battery charge indicator lamp
- CAN bus technology
- Emergency stop button in platform and on frame
- Horn in the platform
- Hour meter
- Integrated diagnostic assistance
- Manual emergency lowering
- Multi-voltage integrated charger
- Negative-type braking on rear wheels
- Non-marking, foam-filled tyres
- Pendular arm
- Platform with open-work floor
- Proportional controls
- Protective cover for control panel
- Slings and securing rings
- Tool box in platform
- Traction battery

Optionnel

- Air predisposition
- Beep on every movement
- Beep upon travel
- Centralized recharging of battery
- Extreme cold oil
- Flashing Light
- Lockable fuel cap
- Personalized paintwork
- SMS : Safe Man System
- Safety harness
- Water predisposition
- Working headlight in platform

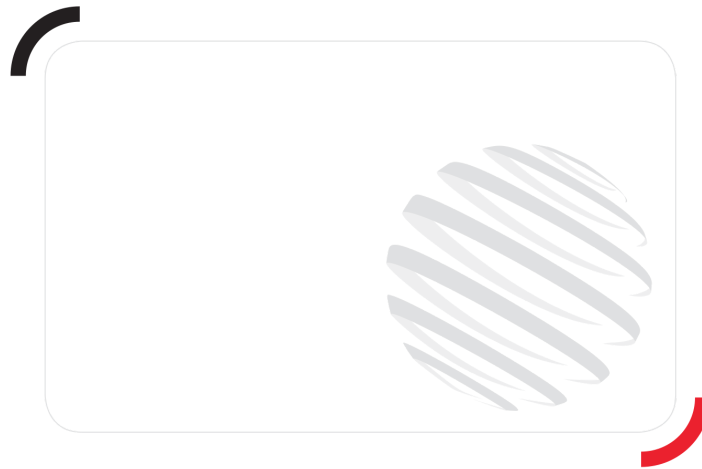

Siège Social

430 rue de l'Aubinière - 44150 Ancenis Cedex - France

Tel: +33(0)2 40 09 10 11 - Fax: +33 (0)2 40 09 10 97

www.manitou.com



Cette publication présente le descriptif des versions et possibilités de configuration des produits Manitou qui peuvent différer en équipement. Les équipements présentés dans cette brochure peuvent être de série, en option, ou non disponibles suivant les versions. Manitou se réserve le droit, à tout moment et sans préavis, de modifier les spécifications décrites et représentées. Les spécifications portées n'engagent pas le constructeur. Pour plus de détails, contactez votre concessionnaire Manitou. Document non contractuel. Présentation des produits non contractuelle. List des spécifications non exhaustive. Les logos ainsi que l'identité visuelle de l'entreprise sont la propriété de Manitou et ne peuvent être utilisés sans autorisation. Tous droits réservés. Les photos et schémas contenus dans la présente brochure ne sont fournis qu'à des fins de consultation et à titre indicatif.

MANITOU BF SA - Société anonyme à conseil d'administration - Capital social : 39 547 824 euros - 857 802 508 RCS Nantes