

Intra Touch Intra Contour

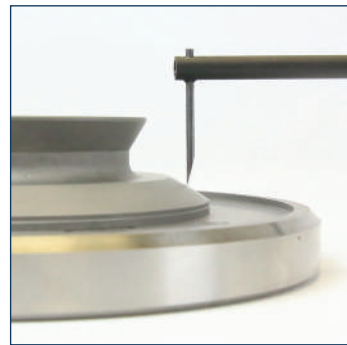
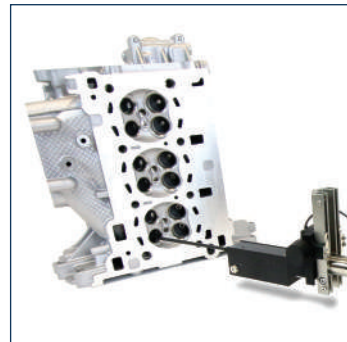

Precision shop floor solutions for
surface finish and contour measurement

Intra Range

Roughness and contour measurement Measure both with a single gauge

Housed in a rugged casing, the Intra has a proven history of maintaining accuracy of measurement without the need for constant maintenance or support.

Quality, flexibility and ease-of-use have enabled the Intra to become a portable shop-floor standard across a wealth of different industries. The Intra combines industry leading specification with simplicity of operation for unbeatable practicality and value.

Advanced contour measurement

Cost effective, robust and portable contour solution with built in 90 mm Z height and optional 350 mm column.

- Simple, single user interface for calibration, measurement and analysis
- Patented ball calibration
- Precision glass scale
- Excellent temperature stability
- Roughness and contour on single gauge

Gauge linearity

Unless your measurements are all taken within the same vertical position of the gauge range and never exceed the amplitude of the step height master, the data you collect may be non-linear which will cause incorrect results.

Using ball calibration is more reliable than the step height master as this eliminates non-linearity.

The Intra is calibrated using a unique patented ball calibration to check linearity of the entire gauge range. Many other systems can only use a few points in the range.



Intra Touch with high precision right-angle gauge

Traverse accuracy

Many roughness checkers are time based, collecting data for a fixed period of time instead of a precise, constant distance. Anything that affects speed of traverse – wear, dirt, slippage, etc. – affects the quantity and spacing of the collected data points which in turn affect the measurement results.

The Intra utilises a glass scale and reading head to ensure that data collection is accurate and consistent.

Every measurement on every instrument is calculated from the exact same quantity of identically spaced data points.



High precision gauge

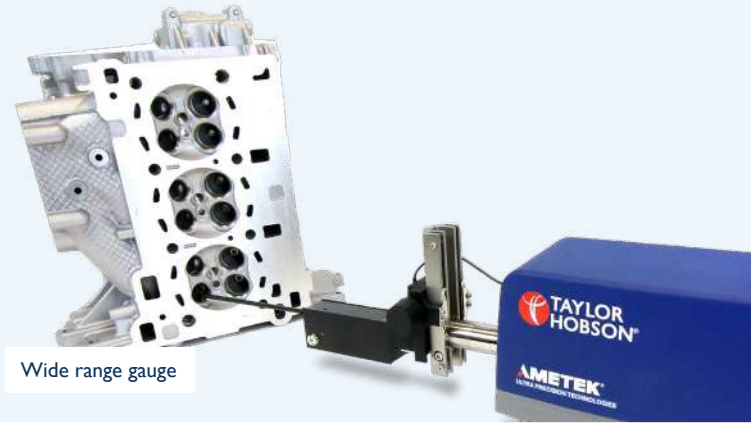

Wide range gauge

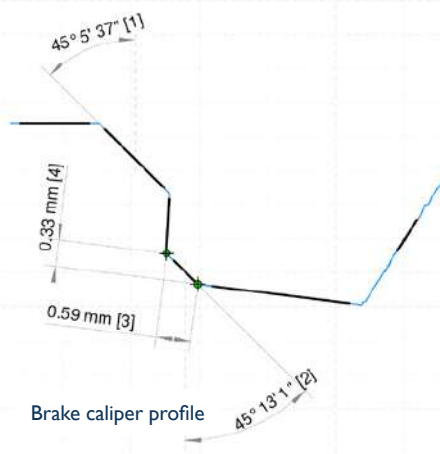

Brake caliper profile

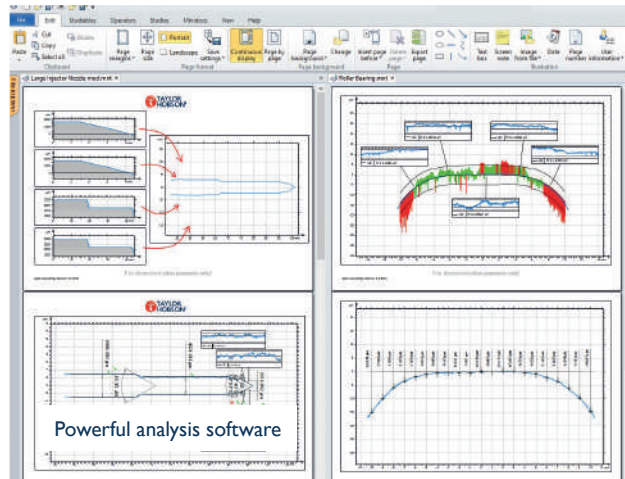

Powerful analysis software

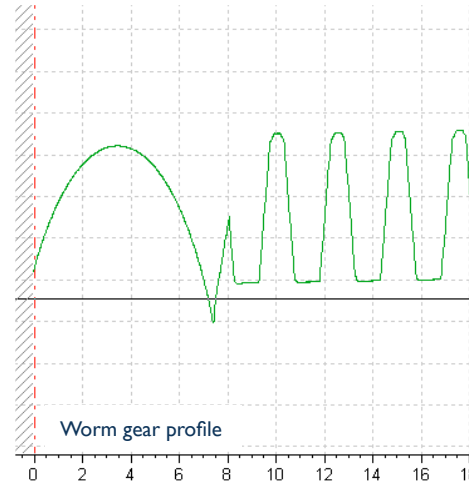

Worm gear profile

Two gauges to meet all of your demands

High precision gauge

This head leads the industry with up to 2 mm (0.08 in) of range and an outstanding range to resolution ratio of 262,144:1.

1 mm - range/resolution

- 1 mm / 4 nm (0.04 in / 0.16 μ m)
- 0.2 mm / 0.8 nm (0.008 in / 0.03 μ m)

2 mm - range/resolution

- 2 mm / 8 nm (0.08 in / 0.31 μ m)
- 0.4 mm / 1.6 nm (0.016 in / 0.06 μ m)

* Contour measurement only.

Wide range gauge

The wide range gauge provides up to 32 mm (1.26 in) of range with 15 nm (4.8 μ m) resolution. Suitable for form and contour measurements.

20 mm - range/resolution

- 20 mm / 76 nm (0.79 in / 3 μ m)
- 4 mm / 15 nm (0.16 in / 0.6 μ m)

32 mm* - range/resolution

- 32 mm / 125 nm (1.26 in / 4.8 μ m)
- 6.4 mm / 25 nm (0.25 in / 1.0 μ m)

Four stylus tip options available

- 5 μ m roughness tip
- 20 μ m chisel tip with 15° included angle
- 0.5 mm (0.02 in) ball tip radius
- 20 μ m conical tip with 30° included angle

Designed to suit your application

Meeting the ever increasing demands of next generation technologies

Measuring brake calliper profile

Measure undercut in two measurements and join them together for analysis

- Intra Contour (wide range gauge)
- 20 mm chisel tip stylus
- TalyProfile Contour software

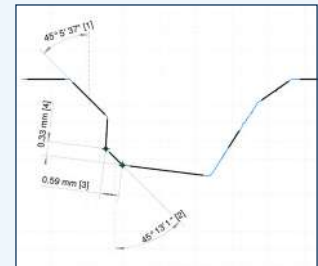

Measuring worm gear profiles

Analyse the complete profile for quality checking of parts

- Intra Contour (wide range gauge)
- 20 mm chisel tip stylus
- Ultra Contour software

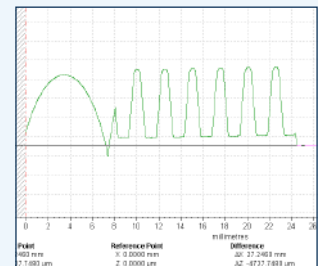
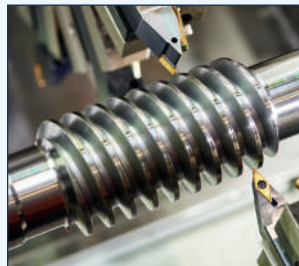

Measuring band saw blades

Identify 'chatter' and surface finish variations which can cause fatigue

- Intra Touch (high precision gauge)
- 1 mm stylus, column, precision vice and manual Y-stage
- TalyProfile software

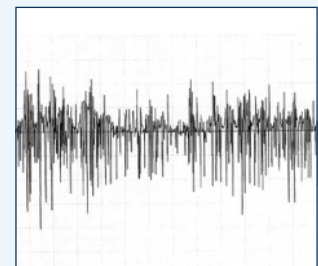

Measuring engine valve grooves

Inspection of parts to eliminate expensive rejects

- Intra Contour (wide range gauge)
- 2 mm special knife edge stylus
- TalyProfile Contour software

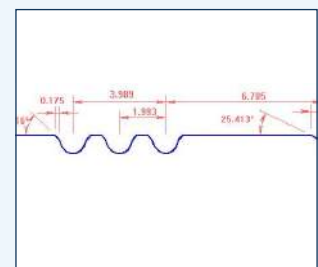

Measuring bearing groove

Complete profile quality check on bearings

- Intra Touch (high precision gauge)
- 20 mm chisel tip stylus used in high gain mode (4 mm range)
- TalyProfile Contour software

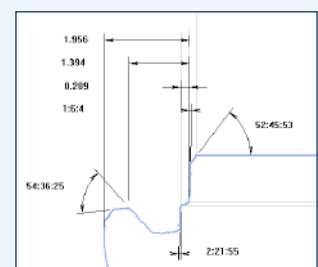



Key analysis features

Unparalleled measurement capability for surface finish and contour

Contour & Roughness

- Angle, radius & distance
- Form error / Pt
- Arc roughness
- Tolerancing

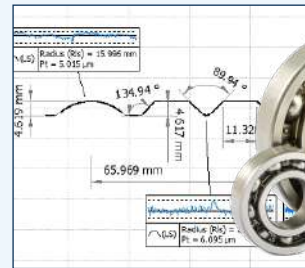
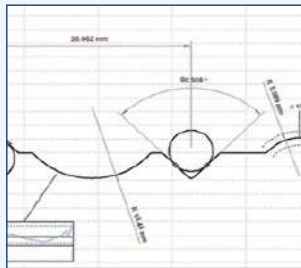

Roughness & Waviness

- 150 Parameters
- ISO 4287
- ISO 13565-2
- ISO 12085

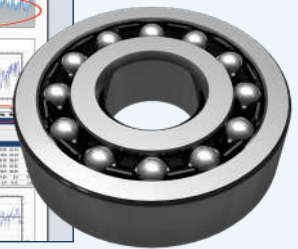
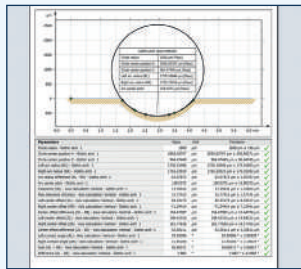

Advanced Contour

- V-groove analysis
- Gothic arch analysis
- Auto dimensioning
- DXF import and export

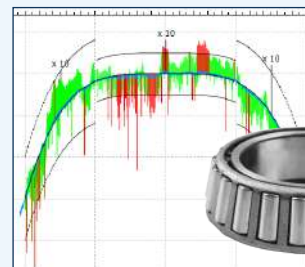
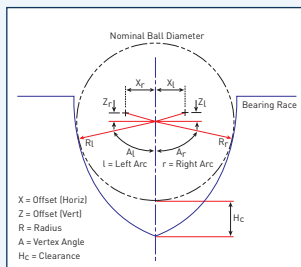

Screws / Steps

- Screw threads
- Ball screws
- Bone screws
- Fluid dynamic bearings

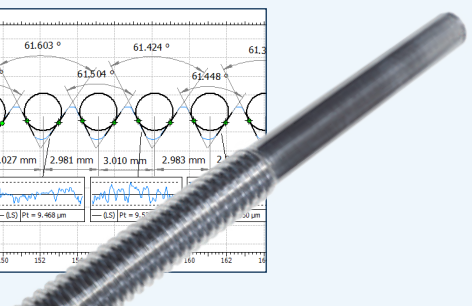
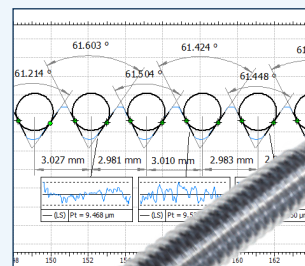

Powerful software - TalyProfile 8

Dedicated, Windows® software package Designed for use with the Intra range

Extensive surface finish analysis

The Intra includes everything needed for the assessment of surface finish.

Fundamental roughness and waviness parameters are included, plus form error analysis, feature exclusion, zoom tool and analysis templates for shop floor applications.

Advanced contour analysis

Contour is an essential tool for geometric dimensioning, tolerancing of profiles and full form deviation analysis.

Save time and increase productivity with automation features within contour analysis, including:

- Gothic arch
- Angle
- DXF fitting
- Roller profile and drops
- Wall / Disc thickness
- Distance measurement

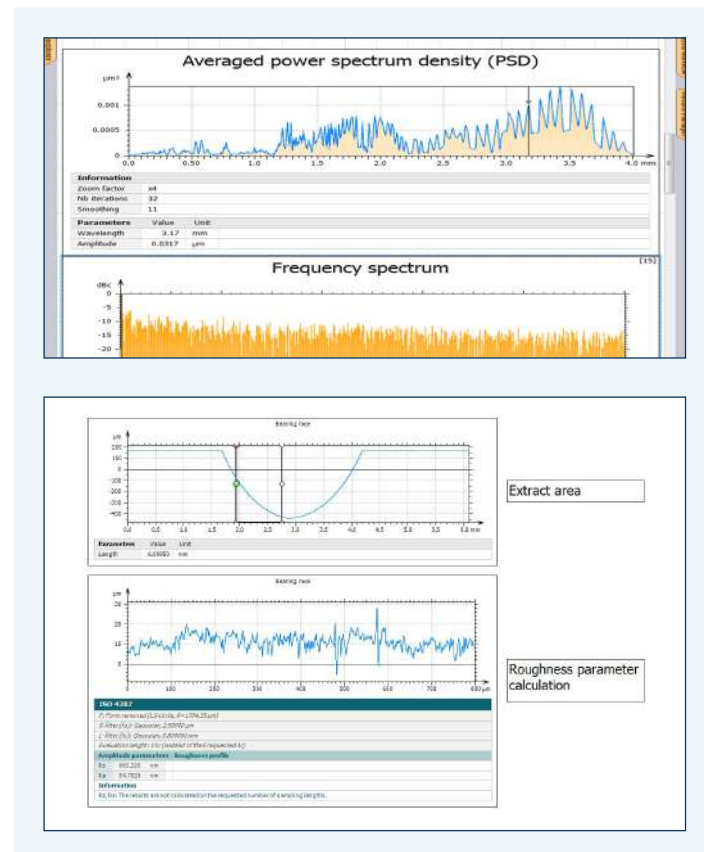

Existing features & benefits

- **Form analysis** - Measure and evaluate radius, angle (slope) and dimension
- **Simple user interface** - Combines simple calibration, measurement and analysis to deliver a true shop floor solution.
- **Dual profile analysis** - Allows comparison of measurements for wear, tolerancing, etc.
- **TalyMap® 3D analysis** - Software utility for topography applications*
- **Pass/Fail tolerances** - All parameters can be assigned nominal, minimum and maximum values.
- **Full compatibility** - Surface finish results from other Taylor Hobson surface roughness instruments can be imported to TalyProfile software, allowing a uniform report style.
- **In depth analysis** - Profiles can be levelled and zoomed to remove unwanted features or defects from the analysis. Distance measurement between features of a profile are easily achieved and the information can be displayed graphically/numerically. Step height and the area of a valley or peak can also be calculated.
- **Desktop publishing facility** - Comprehensive desktop publishing function which allows clear presentation of measurements, results and profiles.
- **Advanced time-saving analysis templates** - A 'template' can be created whereby a sequence of analysis functions can be saved and applied to future measurements, turning detailed reporting tasks into routine documents.

Taylor Hobson's unique patented ball calibration routine

The patented routine ensures that the dimensional measurement capability and gauge linearity are calibrated in a single, automated operation.

Using high-precision spherical calibration artefacts that have been produced to exacting standards and then calibrated for radius, form and surface finish in our own UKAS approved laboratory. Our automated routine delivers a true gauge calibration.

In operation the user simply completes a dialogue confirming parameters such as the percentage of gauge range to be used and the traverse speed.

Working from knowledge of the stylus geometry and the dimensions of the calibration standard, the software automatically calculates the measurement properties and drives the traverse unit, completing the calibration with the minimum of operator intervention.

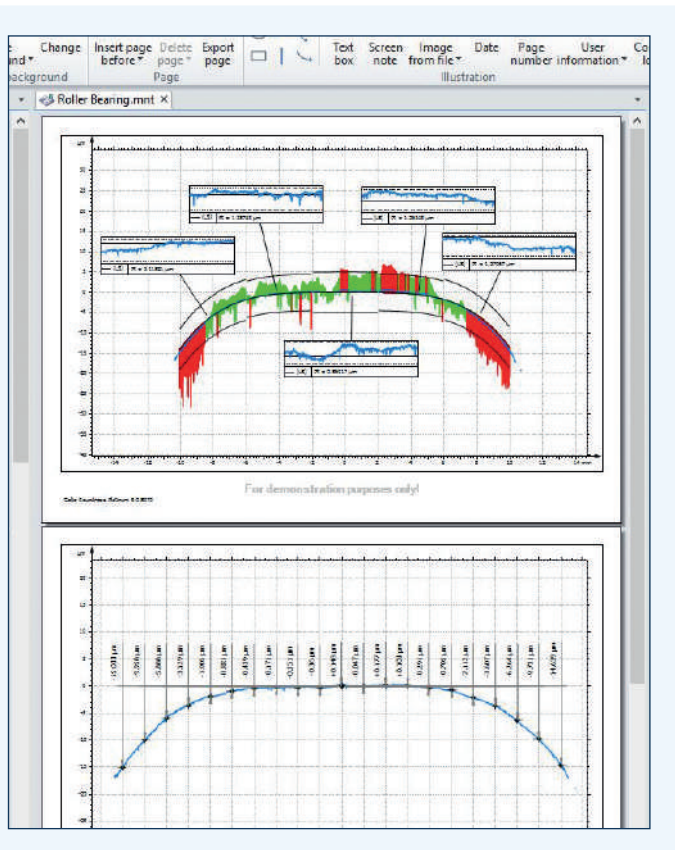

New features & benefits



- **Customised analysis settings**
 - Frequently used analysis settings can be pre-saved and remembered by the software
 - Repetitive analysis can be done in a single click
- **Batch analysis**
 - Analyse multiple measurements as part of one routine
 - Analysing 5 measurements is now 5x quicker!
 - Ensures that each measurement has been analysed the exact same way
- **Undo & redo**
 - Mistakes are fixed with a single click
- **Multiple tabbed documents**
 - The user can compare documents side by side
- **Drag and drop files**
 - View your results quicker
- **Improved parameters calculation (with warnings)**
 - Warnings prevent users from making mistakes such as 'double filtering'
 - Filtering conditions can be displayed inside of the document
- **Quicker calculation times for large datasets**
 - Calculation time has been greatly improved for Gaussian filter and Robust Gaussian filter
- **Quick extraction operators**
 - Analyse the important areas of your part easily
- **Taylor Hobson Advanced Modules (THAMs)**
 - Bespoke analysis modules written for you
- **MATLAB™ operators**
 - Add your own analysis into the software using MATLAB™ scripts

Expanding your capability

Everything you need to begin using Intra touch is supplied as standard. However, for more demanding measuring requirements, we have a range of styli and accessories that may be ordered separately.

Stylus options

1 mm / 2mm (high precision gauge)

<p>D 112-2009 Type: Diamond Reach: 50 mm Shank Clearance: 5.3 mm Tip radius: 2 μm Tip angle: 90° Minimum bore: 10 mm</p>	<p>B 112-2010 Type: Ball Reach: 110 mm Shank Clearance: 11.5 mm Tip radius: 0.5 mm Tip angle: N/A Minimum bore: 17 mm</p>	<p>D 112-2011 Type: Diamond Reach: 50 mm Shank Clearance: 11.3 mm Tip radius: 2 μm Tip angle: 90° Minimum bore: 17 mm</p>
<p>SB 112-2012 Type: Small bore diamond Reach: 50 mm Shank Clearance: 0.42 mm Tip radius: 2 μm Tip angle: 90° Minimum bore: 1.6* mm</p>	<p>C 112-2013 Type: Special chisel Reach: 50 mm Shank Clearance: 5.3 mm Tip radius: 2 μm Tip angle: 90° Minimum bore: 10 mm</p>	<p>D 155-P37279 Type: Diamond Reach: 110 mm Shank Clearance: 11.3 mm Tip radius: 2 μm Tip angle: 90° Minimum bore: 17 mm</p>

20 mm (wide range gauge)

<p>C 112-5444 Type: Chisel Reach: 105 mm Shank Clearance: 20 mm Tip radius: 20 μm Tip angle: 15° Minimum bore: 27 mm</p>	<p>D 112-5446 Type: Diamond Reach: 105 mm Shank Clearance: 20 mm Tip radius: 5 μm Tip angle: 60° Minimum bore: 27 mm</p>	<p>B 112-5462 Type: Ball Reach: 105 mm Shank Clearance: 20 mm Tip radius: 0.5 mm Tip angle: N/A Minimum bore: 27 mm</p>
--	--	--

32 mm (wide range gauge)

<p>C 112-5445 Type: Chisel Reach: 173 mm Shank Clearance: 32 mm Tip radius: 20 μm Tip angle: 15° Minimum bore: 40 mm</p>	<p>B 112-5447 Type: Ball Reach: 173 mm Shank Clearance: 32 mm Tip radius: 0.5 mm Tip angle: N/A Minimum bore: 40 mm</p>	<p>D 112-5463 Type: Diamond Reach: 173 mm Shank Clearance: 32 mm Tip radius: 5 μm Tip angle: 60° Minimum bore: 40 mm</p>
--	--	--

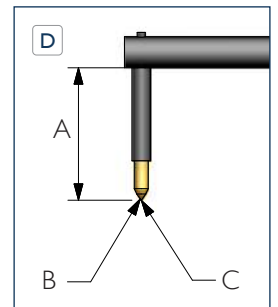

Diamond tip

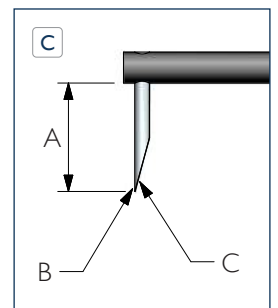

Chisel tip

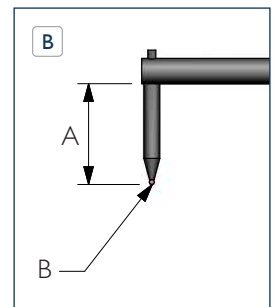

Ball tip

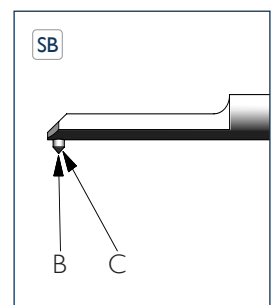

Small bore diamond tip

Styli tip

- A: Shank clearance
- B: Tip radius
- C: Tip angle

Standard Intra accessories

1 Calibration ball/hemisphere

Glass standards for calibrating the Intra systems.

- 12.5 mm (0.49 in) radius
112-2062*
- 38.76 mm (1.526 in) radius
112-5417*

2 Step height and roughness master

- 3 Line (2.5 μm + 0.4 μm) and Ra (0.8 μm)
112-557*
- 0.3 μm Ra glass standard
112-4304*
- 1.6 μm Ra glass standard
112-4303*

3 Vee blocks (pair)

For the positioning and support of large, cylindrical components.

112-1645

4 Precision vice

High carbon steel construction with precision ground faces, 90° vee on clamping jaws.

112-2694

5 Manual Y-stage

Precision stage assembly with Y-axis positioning for component fixturing and cresting.

112-3163

6 Y-stage with vee block

Simple stage assembly with Y-axis positioning and vee block support. 90 x 90 mm (3.5 x 3.5 in).

112-3067

7 Right angled attachment

Allows the stylus and gauge (1 mm & 2 mm only) access to components at 90° to the traverse unit.

112-4485

8 Ball and roller unit

Special fixture for circumferential inspection of surface finish.

112-3219

9 Roller plates

Cylindrical roller plates for balls with diameters of 1 - 16 mm (0.04 - 0.63 in) - set of 3, fits to 112-3219.

112-3248

Ball roller plates

Ball roller plates for balls with diameters of 1 - 25 mm (0.04 - 0.98 in) - set of 4, fits to 112-3219.

112-3247

10 6-Jaw component chuck

Self centring with removable jaws, can be used internally or externally. Mounts kinematically onto table top.

112-1859

11 Customised solutions

Our strategy for success is simple, instead of just selling products, we provide solutions. If our standard instruments and accessories do not satisfy your needs, we can customise a solution to exactly match your application.

Specifications are subject to change without notice.

* UKAS calibration available. Add 'UC' to code.



Specification

System Performance			
Straightness ¹ (over 50 mm)	0.2 µm (7.87 µin)		
Straightness ¹ (over 20 mm)	0.15 µm (5.91 µin)		
Gauge type	High precision		Wide range
Stylus range	1 mm (0.04 in)	2 mm (0.08 in)	20 mm (0.79 in)
Radius accuracy ² (10 - 25 mm)	0.04%	0.04%	0.04%
Radius accuracy ² (25 - 100 mm)	0.08%	0.08%	0.04 - 0.1%
System noise ³ (Rq)	8 nm (0.32 µin)		50 nm (1.97 µin)
Slope accuracy ⁴	0.5 arc minutes		2 arc minutes
Horizontal Performance			
Traverse length - X Min / Max	0.1 mm to 50 mm (0.004 in to 1.97 in)		
Traverse speed	10 mm/s (0.39 in/s) max		
Measuring speeds	0.25 mm/s, 0.5 mm/s, 1 mm/s, & 2 mm/s (0.010 in/s, 0.02 in/s & 0.04 in/s & 0.08 in/s)		
Data sampling interval in X	0.5 µm (20 µin)		
Vertical Performance	High precision		Wide range
Nominal Z (Range 1)	1 mm (0.04 in)	2 mm (0.08 in)	20 mm (0.79 in)
Resolution (Range 1)	4 nm (0.16 in)	8 nm (0.31 in)	75 nm (2.95 in)
Nominal Z (Range 2)	0.2 mm (0.008 in)	0.4 mm (0.016 in)	4 mm (0.16 in)
Resolution (Range 2)	0.8 nm (0.03 in)	1.6 nm (0.06 in)	15 nm (0.59 in)
Roughness stylus max. force	1 mN		3.5 mN
Range to resolution ratio	262,144 : 1		

Analysis		Analysis	
Primary parameters	Pa, Pc, Pda, Pdc*, Pdq, PHSC*, Pku, Plo, Plq, Pmr*, Pp, PPc*, Pq, PS, Psk, Psm, Pt, Pv, Pvo*, Pz	R + W Parameters (ISO 12085)	AR, AW, Pt, R, Rke, Rpke, Rvke, Rx, Sar, Saw, Sr, Sw, W, Wte, Wx
Roughness parameters	R3z, Ra, Rc, Rda, Rdc*, Rdq, RHSC*, Rku, Rlo, Rlq, Rmr*, Rp, Rpc*, Rq, RS, Rsk, RSm, Rt, Rv, Rvo*, Rz	Dimension parameters	Slope, Datum slope, Delta slope, Intercept X / Intercept Z
Waviness parameters	Wa, Wc, Wda, Wdc*, Wdq, WHSC*, Wku, Wlo, Wlq, Wmr*, Wp, WPC*, Wq, WS, Wsk, Wsm, Wt, Wv, Wvo*, Wz	Filters / bandwidths	Rk, Gaussian, Robust Gaussian, ISO 2CR, 2CR PC / 30:1, 100:1, 300:1
Rk Parameters (ISO 13565)	Mr1, Mr2, Rk, Rpk, Rvk, Rpq, Rvq	Cut-offs	0.08, 0.25, 0.8, 2.5 and 8 mm (0.003, 0.010, 0.03, 0.1 and 0.3 in)

Analysis & Parameter Notes		
Pass / Fail tolerances - All parameters can be assigned nominal, minimum and maximum values.	* Qualifiers - All parameters marked with an asterisk are suitable for user assigned single or multiple qualifiers. For example, material ratio (mr) may be assessed at one or more slice levels within a single measurement.	ISO standards - Where applicable, parameters conform to and are named as per ISO standards, 4287, 13565-2 and 12085.

System Information ⁵		Electrical (alternating supply, single phase with earth, 3-wire)	
Dimensions (L x D x H)	421 x 116 x 149 mm (16.6 x 4.6 x 5.9 in)	Instrument and computer voltage	100V to 230V
Weight	4.9 kg (10.8 lbs)	Frequency	47 Hz to 63 Hz
Environment		Power consumption	245 W (Inc. PC, etc.)
Operating temperature (recommended)	18 °C to 22 °C (64 °F to 72 °F)	 Low Voltage Directive 2014/35/EU, EMC Directive 2014/30/EU, Machinery Directive 2006/42/EC, RoHS Directive 2011/65/EU	
Temperature gradient	< 2 °C per hour (< 3.6 °F per hour)		
Operating humidity	45% to 75% relative, non condensing	Compliance to directives is demonstrated using applicable European standards and sections therein.	
Maximum RMS floor vibration	3 µm/s (120 µin/s) at < 50 Hz 6 µm/s (200 µin/s) at > 50 Hz		

Notes

The above technical data is for measurements taken in a metrology laboratory controlled environment: 20°C ± 1°C (68°F ± 1.8°F), draught free, and isolated from low frequency floor borne vibration.

Uncertainties and maximum permissible errors (MPE's) are at 95% confidence in accordance with recommendations in the ISO Guide to the expression of uncertainty in measurement (GUM:1993). All errors are expressed as MPE's.

Qualifiers

1. Measured over a glass flat nominally parallel to the traverse datum with the high precision gauge (speed = 1 mm/s, LS Line analysis, primary filter λs = 2.5 mm).
2. Assumes a calibrated artefact of perfect radius.
3. Measured over a glass flat nominally parallel to the traverse datum (speed = 0.5 mm/s, Gaussian roughness filter, 0.08 mm cut-off, 30:1 bandwidth) - Range 2.
4. Measured upwards at a 35° angled slope over 80% of the gauge range, using a 115 mm arm with a diamond tip.
5. Without gauge and styli. Traverse unit only.

Product dimensions

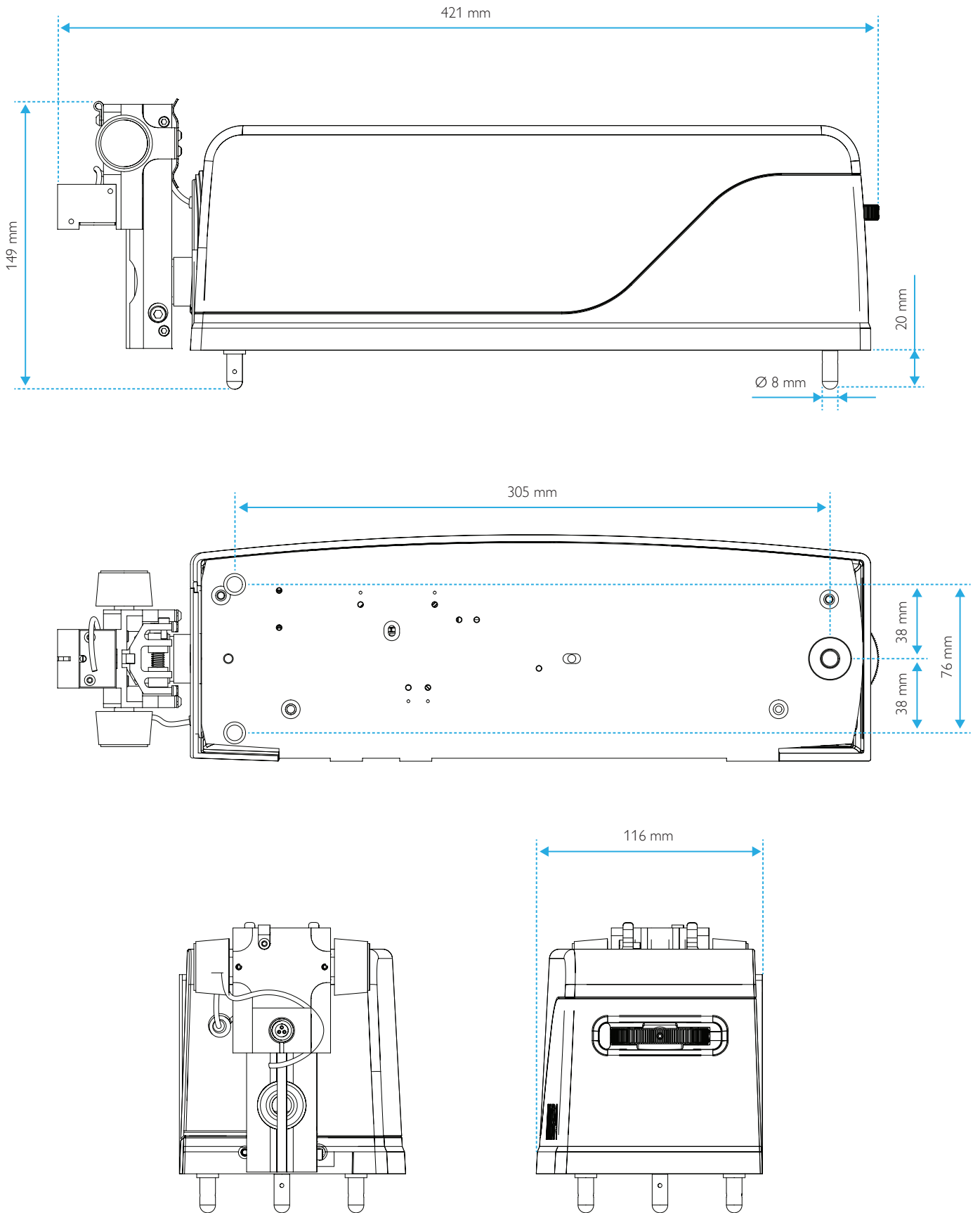

The Metrology Experts

Established in 1886, Taylor Hobson is the world leader in surface and form metrology and developed the first roundness and surface finish measuring instruments.

www.taylor-hobson.com

Sales department

Email: taylor-hobson.sales@ametek.com

Tel: +44 (0) 116 276 3771

- **Design engineering** – special purpose, dedicated metrology systems for demanding applications.
- **Precision manufacturing** – contract machining services for high precision applications and industries.

Centre of Excellence department

Email: taylor-hobson.cofe@ametek.com

Tel: +44 (0) 116 276 3779

- **Inspection services** – measurement of your production parts by skilled technicians using industry leading instruments in accord with ISO standards.
- **Metrology training** – practical, hands-on training courses for roundness and surface finish conducted by experienced metrologists.
- **Operator training** – on-site instruction will lead to greater proficiency and higher productivity.
- **UKAS calibration and testing** – certification for artifacts or instruments in our laboratory or at customer's site.

Service department

Email: taylor-hobson.service@ametek.com

Tel: +44 (0) 116 246 2900

- **Preventative maintenance** – protect your metrology investment with an AMECare support agreement.



© Taylor Hobson Ltd. 2020



Taylor Hobson UK

(Global Headquarters)

PO Box 36, 2 New Star Road
Leicester,
LE4 9JQ,
England

Tel: +44 (0)116 276 3771
taylor-hobson.sales@ametek.com



Taylor Hobson France

Rond Point de l'Épine Champs
Batiment D, 78990 Elancourt, France
Tel: +33 130 68 89 30
taylor-hobson.france@ametek.com



Taylor Hobson Germany

Rudolf-Diesel-Straße 16,
D-64331 Weiterstadt, Germany
Tel: +49 6150 543 0
taylor-hobson.germany@ametek.com



Taylor Hobson Italy

Via Della Liberazione 24, 20068, Peschiera
Borromeo, Zelofoaramagno, Milan, Italy
Tel: +39 02 946 93401
taylor-hobson.italy@ametek.com



Taylor Hobson India

Divyasree NR Enclave, 4th Floor, Block A,
Plot No. 1, EPIP Industrial Area, Whitefield,
Bengaluru - 560066, India
Tel: +91 80 6782 3346
taylor-hobson.india@ametek.com



Taylor Hobson China

taylor-hobson-china.sales@ametek.com

Shanghai Office

Part A1, A4, 2nd Floor, Building No. 1, No. 526
Fute 3rd Road East, Pilot Free Trade Zone,
Shanghai, 200131, China
Tel: +86 21 5868 5111-110

Beijing Office

Western Section, 2nd Floor, Jing Dong Fang
Building (B10), No. 10, Jiu Xian Qiao Road,
Chaoyang District, Beijing, 100015, China
Tel: +86 10 8526 2111

Chengdu Office

No. 9-10, 10th floor, 9/F, High-tech Incubation
Park, No. 160, Jinyue West Road, Chengdu
610041, China
Tel: +86 28 8675 8111

Guangzhou Office

Room 810 Dongbao Plaza, No.767 East
Dongfeng Road, Guangzhou, 510600, China
Tel: +86 20 8363 4768



Taylor Hobson Japan

3F Shiba NBF Tower; 1-1-30, Shiba Daimon
Minato-ku, Tokyo 105-0012, Japan
Tel: +81 34400 2400
taylor-hobson.japan@ametek.com



Taylor Hobson Korea

#309, 3rd FL, Gyeonggi R&DB Center; 105,
Gwanggyo-ro, Yeongtong-gu, Suwon-si,
Gyeonggi-do, Korea, 16229
Tel: +82 31 888 5255
taylor-hobson.korea@ametek.com



Taylor Hobson Singapore

AMETEK Singapore, 10 Ang Mo Kio Street 65,
No. 05-12 Techpoint, Singapore 569059
Tel: +65 6484 2388 Ext 120
taylor-hobson.singapore@ametek.com



Taylor Hobson Thailand

89/45, Moo 15, Enterprise Park, Bangna-Trad
Road, Tambol Bangkaew, Amphur Bangplee,
Samutprakarn Province 10540, Thailand
Tel: +66 2 0127500 Ext 505
taylor-hobson.thailand@ametek.com



Taylor Hobson Taiwan

10F-5, No.120, Sec. 2, Gongdao Wu Rd.,
Hsinchu City 30072, Taiwan
Tel: +886 3 575 0099 Ext 301
taylor-hobson.taiwan@ametek.com



Taylor Hobson Mexico

Acceso III No. 16 Nave 3 Parque Ind. Benito
Juarez Queretaro, Qro. Mexico C.P. 76120
Tel: +52 442 426 4480
taylor-hobson.mexico@ametek.com



Taylor Hobson USA

27755 Diehl Road, Suite 300, Warrenville,
IL 60555, USA
Tel: +1 630 621 3099
taylor-hobson.usa@ametek.com



1100 Cassatt Road, Berwyn, PA 19312, USA
Email: info.corp@ametek.com
Web: www.ametek.com