



Machine Vision Product HikRobot Catalogue



CONTENTS

Company Profile	4
------------------------	---

Product Description

Area Scan Camera

CS Series GigE Area Scan Camera	6
CS Series USB3.0 Area Scan Camera	8
CE Series GigE Area Scan Camera	10
CE Series USB3.0 Area Scan Camera	12
CA Series GigE Area Scan Camera	14
CA Series USB3.0 Area Scan Camera	18
CH Series GigE Area Scan Camera	20
CH Series USB3.0 Area Scan Camera	22
CH Series 10GigE Area Scan Camera	24
CH Series Camera Link Area Scan Camera	28
CH Series CoaXPress Area Scan Camera	30

Line Scan Camera

CL Series GigE Line Scan Camera	34
CL Series Camera Link Line Scan Camera	36

Board Level Camera

CB Series GigE Board Level Camera	38
CB Series USB3.0 Board Level Camera	40

Smart Camera

SC7000 Series Smart Camera	42
SC3000 Series Vision Sensor	44
SC2000E Series Vision Sensor	48
Open Platform Smart Camera	50

Smart Code Reader

ID2000 Series Smart Code Reader	52
ID3000 Series Smart Code Reader	54
ID5000 Series Smart Code Reader	56
ID6000 Series Smart Code Reader	60
IDH Series Handheld Smart Code Reader	62
PD Series Smart Code Reader	64

3D Camera

Line Laser 3D Camera	66
Binocular 3D Camera	68

Vision Box

VB2000 Series Vision Controller	70
VC3000 Series Vision Controller	72

Lens

HF-E Series (1/1.8" 6MP)	76
HF-P Series (1/1.8" 10MP)	78
MF Series (2/3" 8MP)	80
KF-P Series (1.2" 25MP)	82
LF Series (Large Image Circle Lens)	84
Telecentric Lens	86

Machine Vision SDK	88
---------------------------	----

VM Algorithm Development Platform	89
--	----

CodePlatform	93
---------------------	----

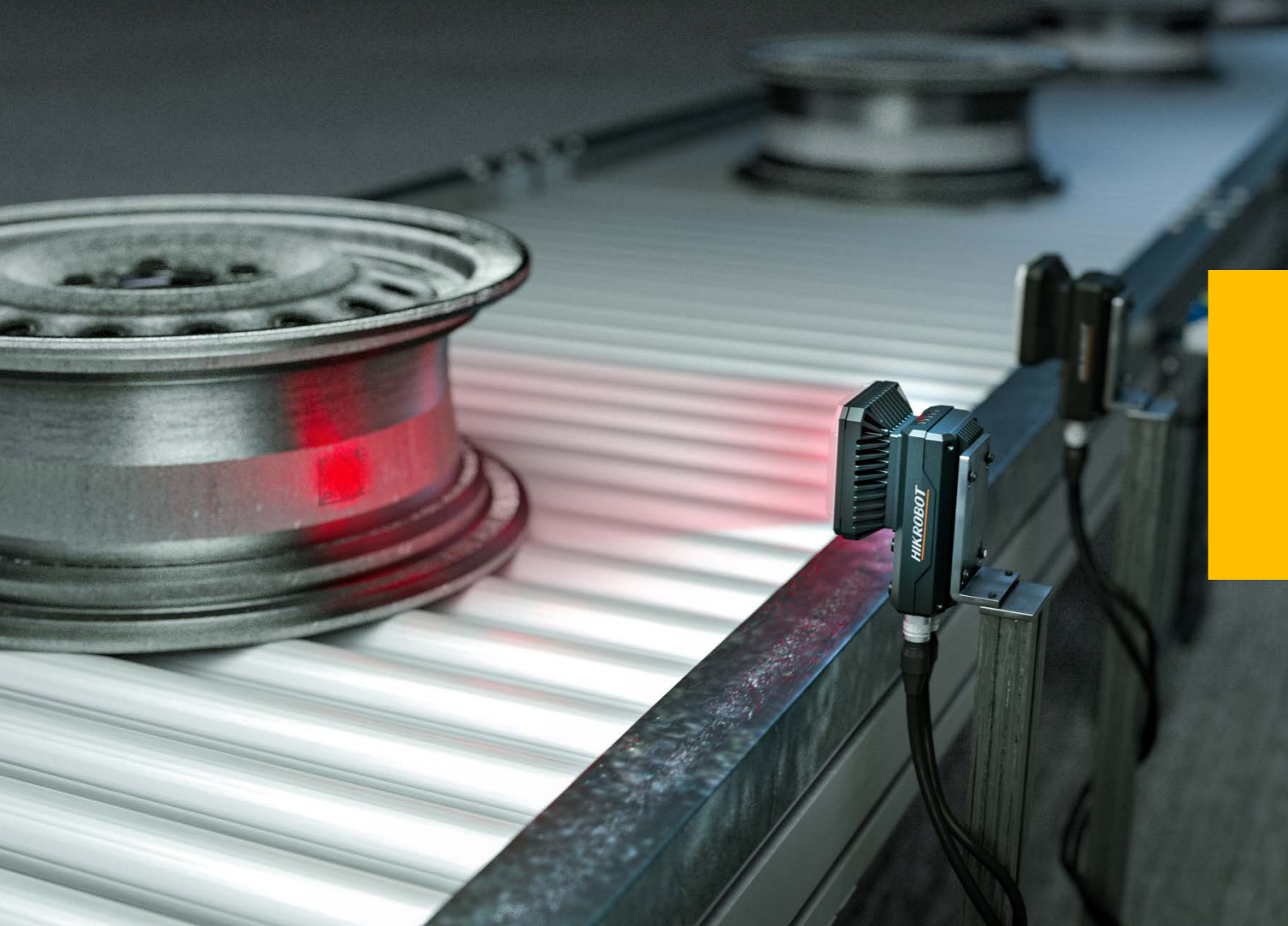

Hangzhou Hikrobot Technology Co.,Ltd.

Hikrobot is a global product and solution supplier specialized in machine vision and mobile robot. Focusing on IIoT, smart logistics and smart manufacturing, we build open cooperation ecosystem, provide service to industry and logistics customers, and commit to continuously promoting the intelligentization and leading the intelligent manufacturing process.

Machine Vision

With efforts in industrial vision sensing application and hardware technology, the company provides customers with leading machine vision products. The products cover industrial camera, lens, vision box, industrial smart camera and related accessory.

Through rigorous EMC, safety and reliability tests, Hikrobot guarantees the high precision, high efficiency and high environmental performance of each product. The machine vision products are widely used in industrial automation sectors such as consumer electronics, semiconductors and logistics, as a part of the vision applications like positioning guidance, measurement, quality inspection, code reading, OCR, etc. They help users to greatly improve productivity, accuracy and stability.

Area Scan Camera

CS Series GigE Area Scan Camera

Key Features

- Second-generation industrial camera, excellent power consumption design.
- A new generation of appearance and structural design that supports installation on four sides.
- Implanting lossless compression and rich ISP functions, including noise reduction,CCM,LSC,super palette,etc.
- GigE interface, with maximum transmission distance up to 100m (without relay).
- Compatible with GigE Vision V2.0 protocol and GenICam standard ,and the third-party software.
- CE, FCC, RoHS, KC certification.



Specifications

Model	Sensor model	Sensor size	Pixel size	Shutter mode	Resolution	Max. frame rate	ADC bit depth	Data interface	Mono/Color	Exposure time	Power consumption	Power supply	Working temperature	Lens mount	Dimension
MV-CS004-10GM	IMX297	1/2.9"	6.9 μm	Global	720 × 540	125 fps	10	GigE	Mono	USE: 1 μs-14 μs NE: 15 μs-10 sec	Typ. 2.2 W@12 VDC	9-24 VDC,PoE	-30-60 °C	C	29 mm × 29 mm × 42 mm
MV-CS004-10GC	IMX297	1/2.9"	6.9 μm	Global	720 × 540	125 fps	10	GigE	Color	USE: 1 μs-14 μs NE: 15 μs-10 sec	Typ. 2.5 W@12 VDC	9-24 VDC,PoE	-30-60 °C	C	29 mm × 29 mm × 42 mm
MV-CS016-10GM	IMX296	1/2.9"	3.45 μm	Global	1440 × 1080	65 fps	10	GigE	Mono	USE: 1 μs-14 μs NE: 15 μs-10 sec	Typ. 2.4 W@12 VDC	9-24 VDC,PoE	-30-60 °C	C	29 mm × 29 mm × 42 mm
MV-CS016-10GC	IMX296	1/2.9"	3.45 μm	Global	1440 × 1080	65 fps	10	GigE	Color	USE: 1 μs-14 μs NE: 15 μs-10 sec	Typ. 2.5 W@12 VDC	9-24 VDC,PoE	-30-60 °C	C	29 mm × 29 mm × 42 mm
MV-CS050-10GM	IMX264	2/3"	3.45 μm	Global	2448 × 2048	24.2 fps	12	GigE	Mono	USE: 1 μs-14 μs NE: 15 μs-10 sec	Typ. 2.6 W@12 VDC	9-24 VDC,PoE	-30-60 °C	C	29 mm × 29 mm × 42 mm
MV-CS050-10GC	IMX264	2/3"	3.45 μm	Global	2448 × 2048	24.2 fps	12	GigE	Color	USE: 1 μs-14 μs NE: 15 μs-10 sec	Typ. 2.9 W@12 VDC	9-24 VDC,PoE	-30-60 °C	C	29 mm × 29 mm × 42 mm
MV-CS050-10GM-PRO	IMX264	2/3"	3.45 μm	Global	2448 × 2048	35.6 fps	12	GigE	Mono	USE: 1 μs-14 μs NE: 15 μs-10 sec	Typ. 2.6 W@12 VDC	9-24 VDC,PoE	-30-60 °C	C	29 mm × 29 mm × 42 mm
MV-CS050-10GC-PRO	IMX264	2/3"	3.45 μm	Global	2448 × 2048	35.6 fps	12	GigE	Color	USE: 1 μs-14 μs NE: 15 μs-10 sec	Typ. 2.9 W@12 VDC	9-24 VDC,PoE	-30-60 °C	C	29 mm × 29 mm × 42 mm
MV-CS050-20GM*	XGS5000	2/3"	3.2 μm	Global	2592 × 2048	22.7fps	12	GigE	Mono	USE: 10 μs-45 μs NE: 46 μs-10 sec	Typ. 2.6 W@12 VDC	9-24 VDC,PoE	-30-60 °C	C	29 mm × 29 mm × 42 mm
MV-CS050-20GC*	XGS5000	2/3"	3.2 μm	Global	2592 × 2048	22.7fps	12	GigE	Color	USE: 10 μs-45 μs NE: 46 μs-10 sec	Typ. 2.6 W@12 VDC	9-24 VDC,PoE	-30-60 °C	C	29 mm × 29 mm × 42 mm
MV-CS060-10GM	IMX178	1/1.8"	2.4 μm	Rolling	3072 × 2048	19.1 fps	12	GigE	Mono	NE: 26 μs-2.5 sec	Typ. 2.4 W@12 VDC	9-24 VDC,PoE	-30-60 °C	C	29 mm × 29 mm × 42 mm
MV-CS060-10GC	IMX178	1/1.8"	2.4 μm	Rolling	3072 × 2048	19.1 fps	12	GigE	Color	NE: 26 μs-2.5 sec	Typ. 2.5 W@12 VDC	9-24 VDC,PoE	-30-60 °C	C	29 mm × 29 mm × 42 mm
MV-CS060-10GM-PRO	IMX178	1/1.8"	2.4 μm	Rolling	3072 × 2048	30.7 fps	12	GigE	Mono	NE: 26 μs-2.5 sec	Typ. 2.4 W@12 VDC	9-24 VDC,PoE	-30-60 °C	C	29 mm × 29 mm × 42 mm
MV-CS060-10GC-PRO	IMX178	1/1.8"	2.4 μm	Rolling	3072 × 2048	30.7 fps	12	GigE	Color	NE: 26 μs-2.5 sec	Typ. 2.5 W@12 VDC	9-24 VDC,PoE	-30-60 °C	C	29 mm × 29 mm × 42 mm

Model	Sensor model	Sensor size	Pixel size	Shutter mode	Resolution	Max. frame rate	ADC bit depth	Data interface	Mono/Color	Exposure time	Power consumption	Power supply	Working temperature	Lens mount	Dimension
MV-CS200-106M	IMX183	1"	2.4 μm	Rolling	5472 × 3648	5.9 fps	10	GigE	Mono	NE:46 μs~2.5 sec	Typ. 2.8 W@12 VDC	9~24 VDC,PoE	-30~60 °C	C	29 mm × 29 mm × 42 mm
MV-CS200-106C	IMX183	1"	2.4 μm	Rolling	5472 × 3648	5.9 fps	10	GigE	Color	NE:46 μs~2.5 sec	Typ. 2.8 W@12 VDC	9~24 VDC,PoE	-30~60 °C	C	29 mm × 29 mm × 42 mm

Notice: * will be released soon.
 USE:Ultra-short exposure mode
 NE:Normal exposure mode

Dimension

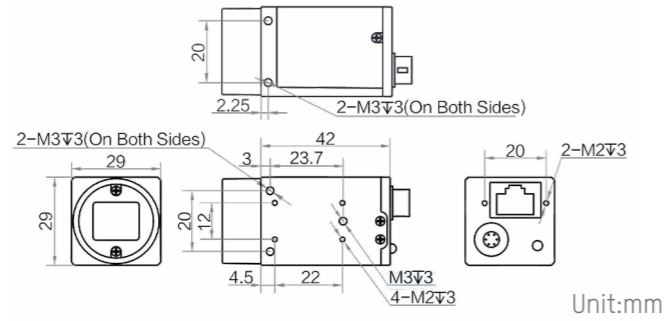

CS Series USB3.0 Area Scan Camera

Key Features

- Second-generation industrial camera, excellent power consumption design.
- A new generation of appearance and structural design that supports installation on four sides.
- Implanting lossless compression and rich ISP functions, including noise reduction,CCM,LSC,super palette, etc.
- USB 3.0 interface, support USB power supply, body lock screw holes to improve installation stability.
- Compatible with USB3 Vision protocol and GenICam standard, and the third-party software.
- CE, FCC, RoHS, KC certification.



Specifications

Model	Sensor model	Sensor size	Pixel size	Shutter mode	Resolution	Max. frame rate	ADC bit depth	Data interface	Mono/Color	Exposure time	Power consumption	Power supply	Working temperature	Lens mount	Dimension
MV-CS060-10UM-PRO	IMX178	1/1.8"	2.4 μm	Rolling	3072 × 2048	59.6 fps	10	USB3.0	Mono	8 us~1 sec	Typ. 2.3 W@5 VDC	9~24 VDC,USB3.0	-30~60°C	C	29 mm × 29 mm × 30 mm
MV-CS060-10UC-PRO	IMX178	1/1.8"	2.4 μm	Rolling	3072 × 2048	59.6 fps	10	USB3.0	Color	8 us~1 sec	Typ. 2.5 W@5 VDC	9~24 VDC,USB3.0	-30~60°C	C	29 mm × 29 mm × 30 mm

Dimension

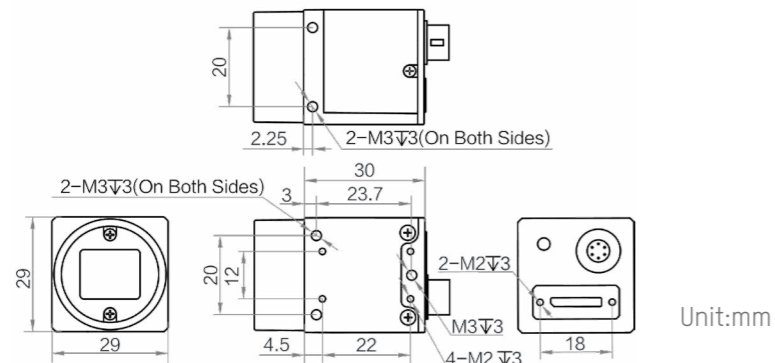

CE Series GigE Area Scan Camera

Key Features

- Adopts high cost-effective sensor, ideal image quality.
- Rolling Shutter cameras support Global Reset mode: cooperate with strobe LED light source to obtain images without smear in moving environment.
- GigE interface, with maximum transmission distance up to 100m (without relay).
- Compatible with GigE Vision V2.0 protocol and GenICam standard, and the third-party software.
- CE, FCC, RoHS, KC certification.



Specifications

Model	Sensor model	Sensor size	Pixel size	Shutter mode	Resolution	Max. frame rate	Bit depth	Data interface	Mono/Color	Exposure time	Power consumption	Power supply	Working temperature	Lens mount	Dimension	Label
MV-CE003-20GM	PYTHON	1/3.6"	4.8 μm	Global	640 × 480	173 fps	10	GigE	Mono	42 μs-10 sec	Typ. 3.0 W@12 VDC	12 VDC, PoE	0-50°C	C	29 mm × 29 mm × 42 mm	A
MV-CE003-20GC	PYTHON	1/3.6"	4.8 μm	Global	640 × 480	173 fps	10	GigE	Color	42 μs-10 sec	Typ. 3.0 W@12 VDC	12 VDC, PoE	0-50°C	C	29 mm × 29 mm × 42 mm	A
MV-CE013-80GM*	SS	1/2.7"	4.0 μm	Global	1280 × 1024	90 fps	10	GigE	Mono	30 μs-10 sec	Typ. 2 W@12 VDC	9-24 VDC, PoE	0-50°C	C	29 mm × 29 mm × 42 mm	A
MV-CE013-80GC*	SS	1/2.7"	4.0 μm	Global	1280 × 1024	90 fps	10	GigE	Color	30 μs-10 sec	Typ. 2 W@12 VDC	9-24 VDC, PoE	0-50°C	C	29 mm × 29 mm × 42 mm	A
MV-CE020-10GC	IMX290	1/2.8"	2.9 μm	Rolling	1920 × 1080	58 fps	12	GigE	Color	15 μs-2 sec	Typ. 2.4 W@12 VDC	9-24 VDC, PoE	0-50°C	C	29 mm × 29 mm × 42 mm	A
MV-CE050-31GM	AR0521	1/2.5"	2.2 μm	Rolling	2592 × 1944	24 fps	12	GigE	Mono	21 μs-1 sec	Typ. 2.4 W@12 VDC	9-24 VDC, PoE	0-50°C	C	29 mm × 29 mm × 42 mm	A
MV-CE050-31GC	AR0521	1/2.5"	2.2 μm	Rolling	2592 × 1944	24 fps	12	GigE	Color	21 μs-1 sec	Typ. 2.4 W@12 VDC	9-24 VDC, PoE	0-50°C	C	29 mm × 29 mm × 42 mm	A
MV-CE100-30GC	MT9J003	1/2.3"	1.67 μm	Rolling	3840 × 2748	7 fps	12	GigE	Color	50 μs-2 sec	Typ. 2.6 W@12 VDC	12 VDC, PoE	0-50°C	C	29 mm × 29 mm × 42 mm	A
MV-CE100-31GM	MT9J003	1/2.3"	1.67 μm	Rolling	3840 × 2748	11.2 fps	12	GigE	Mono	26 μs-1 sec	Typ. 2.6 W@12 VDC	12 VDC, PoE	0-50°C	C	29 mm × 29 mm × 42 mm	A
MV-CE120-10GM	IMX226	1/1.7"	1.85 μm	Rolling	4024 × 3036	9.6 fps	10	GigE	Mono	34 μs-2 sec	Typ. 2.7 W@12 VDC	12 VDC, PoE	0-50°C	C	29 mm × 29 mm × 42 mm	A
MV-CE120-10GC	IMX226	1/1.7"	1.85 μm	Rolling	4024 × 3036	9.6 fps	10	GigE	Color	34 μs-2 sec	Typ. 3.0 W@12 VDC	12 VDC, PoE	0-50°C	C	29 mm × 29 mm × 42 mm	A
MV-CE200-10GM	IMX183	1"	2.4 μm	Rolling	5472 × 3648	5.9 fps	10	GigE	Mono	46 μs-2 sec	Typ. 3.5 W@12 VDC	12 VDC, PoE	0-50°C	C	44 mm × 29 mm × 59 mm	B
MV-CE200-10GC	IMX183	1"	2.4 μm	Rolling	5472 × 3648	5.9 fps	10	GigE	Color	46 μs-2 sec	Typ. 3.5 W@12 VDC	12 VDC, PoE	0-50°C	C	44 mm × 29 mm × 59 mm	B
MV-CE200-11GM	IMX183	1"	2.4 μm	Rolling	5472 × 3648	5.9 fps	10	GigE	Mono	46 μs-2 sec	Typ. 2.9 W@12 VDC	9-24 VDC, PoE	0-50°C	C	29 mm × 29 mm × 42 mm	A

Notice: * will be released soon.

Dimension

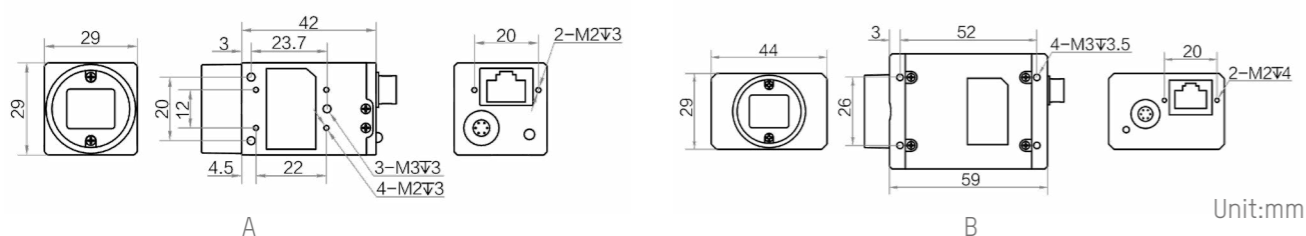

CE Series USB3.0 Area Scan Camera

Key Features

- Adopts high cost-effective sensor, ideal image quality.
- Rolling Shutter cameras support Global Reset mode: cooperate with strobe LED light source to obtain images without smear in moving environment.
- USB 3.0 interface, support USB power supply, body lock screw holes to improve installation stability.
- Compatible with USB3 Vision Protocol, GenICam standard, and the third-party software.
- CE, FCC, RoHS, KC certification.



Specifications

Modelv	Sensor model	Sensor size	Pixel size	Shutter mode	Resolution	Max. frame rate	ADC bit depth	Data interface	Mono/Color	Exposure time	Power consumption	Power supply	Working temperature	Lens mount	Dimension	Label
MV-CE013-80UM	SS	1/2.7"	4.0 μm	Global	1280 × 1024	150 fps	10	USB3.0	Mono	30 μs-10 sec	Typ. 1.93 W@5 VDC	12 VDC, USB3.0	0-50°C	C	29 mm × 29 mm × 30 mm	A
MV-CE050-30UM	AR0521	1/2.5"	2.2 μm	Rolling	2592 × 1944	44.7 fps	10	USB3.0	Mono	28 μs-0.6 sec	Typ. 2.5 W @5 VDC	9-24 VDC, USB3.0	0-50°C	C	29 mm × 29 mm × 30 mm	B
MV-CE050-30UC	AR0521	1/2.5"	2.2 μm	Rolling	2592 × 1944	44.7 fps	10	USB3.0	Color	28 μs-0.6 sec	Typ. 2.5 W @5 VDC	12 VDC, USB3.0	0-50°C	C	29 mm × 29 mm × 30 mm	A
MV-CE060-10UM	IMX178	1/1.8"	2.4 μm	Rolling	3072 × 2048	42.7 fps	12	USB3.0	Mono	24 μs-1 sec	Typ. 2.7 W@5 VDC	12 VDC, USB3.0	0-50°C	C	29 mm × 29 mm × 30 mm	A
MV-CE060-10UC	IMX178	1/1.8"	2.4 μm	Rolling	3072 × 2048	42.7 fps	12	USB3.0	Color	16 μs-1 sec	Typ. 2.7 W@5 VDC	12 VDC, USB3.0	0-50°C	C	29 mm × 29 mm × 30 mm	A
MV-CE120-10UM	IMX226	1/1.7"	1.85 μm	Rolling	4000 × 3036	31.9 fps	10	USB3.0	Mono	30 μs-0.5 sec	Typ. 3.18 W@5 VDC	9-24 VDC, USB3.0	0-50°C	C	29 mm × 29 mm × 30 mm	B
MV-CE120-10UC	IMX226	1/1.7"	1.85 μm	Rolling	4000 × 3036	31.9 fps	10	USB3.0	Color	20 μs-0.5 sec	Typ. 3.42 W@5 VDC	9-24 VDC, USB3.0	0-50°C	C	29 mm × 29 mm × 30 mm	B
MV-CE200-10UM	IMX183	1"	2.4 μm	Rolling	5472 × 3648	19.2 fps	10	USB3.0	Mono	44 μs-0.7 sec	Typ. 2.83 W@5 VDC	12 VDC, USB3.0	0-50°C	C	44 mm × 29 mm × 59 mm	C
MV-CE200-10UC	IMX183	1"	2.4 μm	Rolling	5472 × 3648	19.2 fps	10	USB3.0	Color	28 μs-0.7 sec	Typ. 2.83 W@5 VDC	12 VDC, USB3.0	0-50°C	C	44 mm × 29 mm × 59 mm	C
MV-CE200-11UM	IMX183	1"	2.4 μm	Rolling	5472 × 3648	19.2 fps	10	USB3.0	Mono	28 μs-0.7 sec	Typ. 2.83 W@5 VDC	9-24 VDC, USB3.0	0-50°C	C	29 mm × 29 mm × 30 mm	B
MV-CE200-11UC	IMX183	1"	2.4 μm	Rolling	5472 × 3648	19.2 fps	10	USB3.0	Color	28 μs-0.62 sec	Typ. 2.67 W@5 VDC	9-24 VDC, USB3.0	0-50°C	C	29 mm × 29 mm × 30 mm	B

Dimension

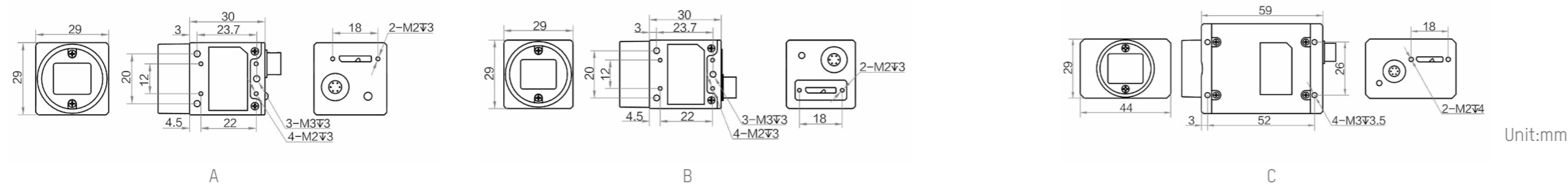

■ CA Series GigE Area Scan Camera

Key Features

- Based on the global shutter sensor, covering the needs of mainstream applications.
- GigE interface, with maximum transmission distance up to 100m (without relay).
- Compatible with GigE Vision V2.0 protocol and GenICam standard, and the third-party software.
- CE, FCC, RoHS, KC certification.



Specifications

Model	Sensor model	Sensor size	Pixel size	Shutter mode	Resolution	Max. frame rate	Bit depth	Data interface	Mono/Color	Exposure time	Power consumption	Power supply	Working temperature	Lens mount	Dimension	Label
MV-CA003-20GM	PYTHON300	1/4"	4.8 μm	Global	672 × 512	336 fps	10	GigE	Mono	NE:40 μs-10 sec	Typ. 2.6 W @ 12 VDC	12 VDC,PoE	0-50°C	C	29 mm × 29 mm × 42 mm	A
MV-CA003-20GC	PYTHON300	1/4"	4.8 μm	Global	672 × 512	336 fps	10	GigE	Color	NE:49 μs-10 sec	Typ. 2.6 W @ 12 VDC	12 VDC,PoE	0-50°C	C	29 mm × 29 mm × 42 mm	A
MV-CA004-10GM	IMX287	1/2.9"	6.9 μm	Global	720 × 540	312.9 fps	12	GigE	Mono	NE:1 μs-10 sec	Typ. 3.1 W@12 VDC	9-24 VDC,PoE	0-50°C	C	29 mm × 29 mm × 42 mm	A
MV-CA004-10GC	IMX287	1/2.9"	6.9 μm	Global	720 × 540	312.9 fps	12	GigE	Color	NE:1 μs-10 sec	Typ. 3.1 W@12 VDC	9-24 VDC,PoE	0-50°C	C	29 mm × 29 mm × 42 mm	A
MV-CA005-20GM	PYTHON480	1/3.6"	4.8 μm	Global	808 × 608	116 fps	10	GigE	Mono	NE:42 μs-10 sec	Typ. 3.0 W@12 VDC	12 VDC,PoE	0-50°C	C	29 mm × 29 mm × 42 mm	A
MV-CA005-20GC	PYTHON480	1/3.6"	4.8 μm	Global	808 × 608	116 fps	10	GigE	Color	NE:42 μs-10 sec	Typ. 3.0 W@12 VDC	12 VDC,PoE	0-50°C	C	29 mm × 29 mm × 42 mm	A
MV-CA013-20GM	PYTHON1300	1/2"	4.8 μm	Global	1280 × 1024	90 fps	10	GigE	Mono	NE:62 μs-10 sec	Typ. 2.7 W@12 VDC	12 VDC,PoE	0-50°C	C	29 mm × 29 mm × 42 mm	A
MV-CA013-20GC	PYTHON1300	1/2"	4.8 μm	Global	1280 × 1024	90 fps	10	GigE	Color	NE:38 μs-10 sec	Typ. 2.7 W@12 VDC	12 VDC,PoE	0-50°C	C	29 mm × 29 mm × 42 mm	A
MV-CA016-10GM	IMX273	1/2.9"	3.45 μm	Global	1440 × 1080	78.2 fps	12	GigE	Mono	NE:1 μs-10 sec	Typ. 3 W@12 VDC	9-24 VDC,PoE	0-50°C	C	29 mm × 29 mm × 42 mm	A
MV-CA016-10GC	IMX273	1/2.9"	3.45 μm	Global	1440 × 1080	78.2 fps	12	GigE	Color	NE:1 μs-10 sec	Typ. 3 W@12 VDC	9-24 VDC,PoE	0-50°C	C	29 mm × 29 mm × 42 mm	A
MV-CA017-10GM	IMX432	1.1"	9 μm	Global	1608 × 1104	68.5 fps	12	GigE	Mono	USE:1 μs-5 μs NE:6 μs-10 sec	Typ. 4.2 W@12 VDC	12 VDC,PoE	0-50°C	C	44 mm × 29 mm × 59 mm	B
MV-CA017-10GC	IMX432	1.1"	9 μm	Global	1608 × 1104	68.5 fps	12	GigE	Color	USE:1 μs-5 μs NE:6 μs-10 sec	Typ. 4.8 W@12 VDC	12 VDC,PoE	0-50°C	C	44 mm × 29 mm × 59 mm	B
MV-CA020-10GM	IMX430	1/1.7"	4.5 μm	Global	1624 × 1240	60 fps	12	GigE	Mono	NE: 1 μs-10 sec	Typ. 3.27 W@12 VDC	9-24 VDC,PoE	0-50°C	C	29 mm × 29 mm × 42 mm	A
MV-CA020-10GC	IMX430	1/1.7"	4.5 μm	Global	1624 × 1240	60 fps	12	GigE	Color	NE: 1 μs-10 sec	Typ. 3.6 W@12 VDC	9-24 VDC,PoE	0-50°C	C	29 mm × 29 mm × 42 mm	A
MV-CA020-20GM	PYTHON2000	2/3"	4.8 μm	Global	1920 × 1200	52.7 fps	10	GigE	Mono	NE:59 μs-10 sec	Typ. 2.9 W@12 VDC	12 VDC,PoE	0-50°C	C	29 mm × 29 mm × 42 mm	A
MV-CA020-20GC	PYTHON2000	2/3"	4.8 μm	Global	1920 × 1200	52.7 fps	10	GigE	Color	NE:59 μs-10 sec	Typ. 2.9 W@12 VDC	12 VDC,PoE	0-50°C	C	29 mm × 29 mm × 42 mm	A
MV-CA023-10GM	IMX249	1/1.2"	5.86 μm	Global	1920 × 1200	41 fps	12	GigE	Mono	NE: 34 μs-10 sec	Typ. 2.9 W@12 VDC	12 VDC,PoE	0-50°C	C	29 mm × 29 mm × 42 mm	A

Model	Sensor model	Sensor size	Pixel size	Shutter mode	Resolution	Max. frame rate	Bit depth	Data interface	Mono/Color	Exposure time	Power consumption	Power supply	Working temperature	Lens mount	Dimension	Label
MV-CA023-10GC	IMX249	1/1.2"	5.86 μm	Global	1920 × 1200	41 fps	12	GigE	Color	NE: 34 μs-10 sec	Typ. 3.1 W@12 VDC	12 VDC,PoE	0-50°C	C	29 mm × 29 mm × 42 mm	A
MV-CA032-10GM	IMX265	1/1.8"	3.45 μm	Global	2048 × 1536	37.5 fps	12	GigE	Mono	USE:1 μs-14 μs NE:15 μs-10 sec	Typ. 3.2 W@12 VDC	12 VDC,PoE	0-50°C	C	29 mm × 29 mm × 42 mm	A
MV-CA032-10GC	IMX265	1/1.8"	3.45 μm	Global	2048 × 1536	37.5 fps	12	GigE	Color	USE:1 μs-14 μs NE:15 μs-10 sec	Typ. 3.5 W@12 VDC	12 VDC,PoE	0-50°C	C	29 mm × 29 mm × 42 mm	A
MV-CA050-10GM	IMX264	2/3"	3.45 μm	Global	2448 × 2048	23.5 fps	12	GigE	Mono	USE:1 μs-14 μs NE:15 μs-10 sec	Typ. 3.1 W@12 VDC	12 VDC,PoE	0-50°C	C	29 mm × 29 mm × 42 mm	A
MV-CA050-12GC	IMX264	2/3"	3.45 μm	Global	2448 × 2048	24.1 fps	12	GigE	Color	USE:1 μs-14 μs NE:15 μs-10 sec	Typ. 3.2 W@12 VDC	9-24 VDC,PoE	0-50°C	C	29 mm × 29 mm × 42 mm	A
MV-CA050-20GM	PYTHON5000	1"	4.8 μm	Global	2592 × 2048	22 fps	10	GigE	Mono	NE: 65 μs-10 sec	Typ. 3.3 W@12 VDC	12 VDC,PoE	0-50°C	C	29 mm × 29 mm × 42 mm	A
MV-CA050-20GC	PYTHON5000	1"	4.8 μm	Global	2592 × 2048	22 fps	10	GigE	Color	NE: 65 μs-10 sec	Typ. 3.3 W@12 VDC	12 VDC,PoE	0-50°C	C	29 mm × 29 mm × 42 mm	A
MV-CA050-20GN	PYTHON5000	1"	4.8 μm	Global	2592 × 2048	22 fps	10	GigE	Near-infrared	NE: 65 μs-10 sec	Typ. 3.3 W@12 VDC	12 VDC,PoE	0-50°C	C	29 mm × 29 mm × 42 mm	A
MV-CA060-11GM	IMX178	1/1.8"	2.4 μm	Rolling	3072 × 2048	17 fps	12	GigE	Mono	NE: 27 μs-2.5 sec	Typ. 2.5 W@12 VDC	12 VDC,PoE	0-50°C	C	29 mm × 29 mm × 42 mm	A
MV-CA060-10GC	IMX178	1/1.8"	2.4 μm	Rolling	3072 × 2048	17 fps	12	GigE	Color	NE: 27 μs-2.5 sec	Typ. 3.5 W@12 VDC	12 VDC,PoE	0-50°C	C	29 mm × 29 mm × 42 mm	A

Notice: *USE:Ultra-short exposure mode
NE:Normal exposure mode

Dimension

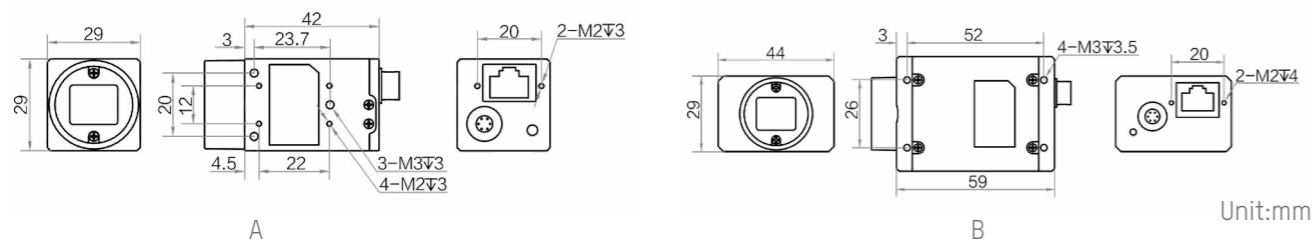

CA Series USB3.0 Area Scan Camera

Key Features

- Based on the global shutter sensor, covering the needs of mainstream applications.
- USB 3.0 interface, support USB power supply, body screw holes improve installation stability.
- Compatible with USB3 Vision protocol and GenICam standard and seamless connection with third-party softwares.
- CE, FCC, RoHS, KC certification.



Specifications

Model	Sensor model	Sensor size	Pixel size	Shutter mode	Resolution	Max. frame rate	ADC bit depth	Data interface	Mono/Color	Exposure time	Power consumption	Power supply	Working temperature	Lens mount	Dimension	Label
MV-CA003-21UM	PYTHON300	1/4"	4.8 μm	Global	640 × 480	814.5 fps	10	USB3.0	Mono	NE: 40 μs-10 sec	Typ. 3.3 W @5 VDC	12 VDC, USB3.0	0-50°C	C	29 mm × 29 mm × 30 mm	A
MV-CA003-21UC	PYTHON300	1/4"	4.8 μm	Global	640 × 480	814.5 fps	10	USB3.0	Color	NE: 40 μs-10 sec	Typ. 3.3 W @5 VDC	12 VDC, USB3.0	0-50°C	C	29 mm × 29 mm × 30 mm	A
MV-CA004-10UM	IMX287	1/2.9"	6.9 μm	Global	720 × 540	526.5 fps	8/12	USB3.0	Mono	USE:1 μs-14 μs NE:15 μs-10 sec	Typ. 3 W@5 VDC	9-24 VDC, USB3.0	0-50°C	C	29 mm × 29 mm × 30 mm	B
MV-CA004-10UC	IMX287	1/2.9"	6.9 μm	Global	720 × 540	526.5 fps	8/12	USB3.0	Color	USE:1 μs-14 μs NE:15 μs-10 sec	Typ. 3 W@5 VDC	9-24 VDC, USB3.0	0-50°C	C	29 mm × 29 mm × 30 mm	B
MV-CA013-21UM	PYTHON1300	1/2"	4.8 μm	Global	1280 × 1024	210 fps	10	USB3.0	Mono	NE: 65 μs-10 sec	Typ. 3 W @5 VDC	12 VDC, USB3.0	0-50°C	C	29 mm × 29 mm × 30 mm	A
MV-CA013-21UC	PYTHON1300	1/2"	4.8 μm	Global	1280 × 1024	210 fps	10	USB3.0	Color	NE:40 μs-10 sec	Typ. 3 W @5 VDC	12 VDC, USB3.0	0-50°C	C	29 mm × 29 mm × 30 mm	A
MV-CA016-10UM	IMX273	1/2.9"	3.45 μm	Global	1440 × 1080	249.1 fps	8/12	USB3.0	Mono	USE:1 μs-14 μs NE:15 μs-10 sec	Typ. 2.8 W @5 VDC	12 VDC, USB3.0	0-50°C	C	29 mm × 29 mm × 30 mm	A
MV-CA016-10UC	IMX273	1/2.9"	3.45 μm	Global	1440 × 1080	249.1 fps	8/12	USB3.0	Color	USE:1 μs-14 μs NE:15 μs-10 sec	Typ. 2.8 W @5 VDC	12 VDC, USB3.0	0-50°C	C	29 mm × 29 mm × 30 mm	A
MV-CA020-10UM	IMX430	1/1.7"	4.5 μm	Global	1624 × 1240	89.1 fps	12	USB3.0	Mono	NE: 1 μs-10 sec	Typ. 3.2 W@5 VDC	9-24 VDC, USB3.0	0-50°C	C	29 mm × 29 mm × 30 mm	B
MV-CA020-10UC	IMX430	1/1.7"	4.5 μm	Global	1624 × 1240	89.1 fps	12	USB3.0	Color	NE: 1 μs-10 sec	Typ. 3.9 W@5 VDC	9-24 VDC, USB3.0	0-50°C	C	29 mm × 29 mm × 30 mm	B
MV-CA023-10UM	IMX249	1/1.2"	5.86 μm	Global	1920 × 1200	40 fps	12	USB3.0	Mono	NE:34 μs-10 sec	Typ. 2.52 W@5 VDC	12 VDC, USB3.0	0-50°C	C	29 mm × 29 mm × 30 mm	A
MV-CA023-10UC	IMX249	1/1.2"	5.86 μm	Global	1920 × 1200	41 fps	12	USB3.0	Color	NE:34 μs-10 sec	Typ. 2.52 W@5 VDC	12 VDC, USB3.0	0-50°C	C	29 mm × 29 mm × 30 mm	A
MV-CA050-11UM	IMX264	2/3"	3.45 μm	Global	2448 × 2048	35.1 fps	12	USB3.0	Mono	USE:1 μs-14 μs NE:15 μs-10 sec	Typ. 2.8 W @5 VDC	12 VDC, USB3.0	0-50°C	C	29 mm × 29 mm × 30 mm	A
MV-CA050-12UC*	IMX264	2/3"	3.45 μm	Global	2448 × 2048	60 fps	12	USB3.0	Color	USE:1 μs-14 μs NE:15 μs-10 sec	Typ. 3.3 W @5 VDC	9-24 VDC, USB3.0	0-50°C	C	29 mm × 29 mm × 30 mm	B
MV-CA050-20UM	PYTHON5000	1"	4.8 μm	Global	2592 × 2048	71.8 fps	10	USB3.0	Mono	NE: 59 μs-10 sec	Typ. 3.5 W@5 VDC	12 VDC, USB3.0	0-50°C	C	29 mm × 29 mm × 30 mm	A
MV-CA050-20UC	PYTHON5000	1"	4.8 μm	Global	2592 × 2048	71.8 fps	10	USB3.0	Color	NE: 59 μs-10 sec	Typ. 3.5 W@5 VDC	12 VDC, USB3.0	0-50°C	C	29 mm × 29 mm × 30 mm	A

Notice: * will be released soon.
 USE:Ultra-short exposure mode
 NE:Normal exposure mode

Dimension

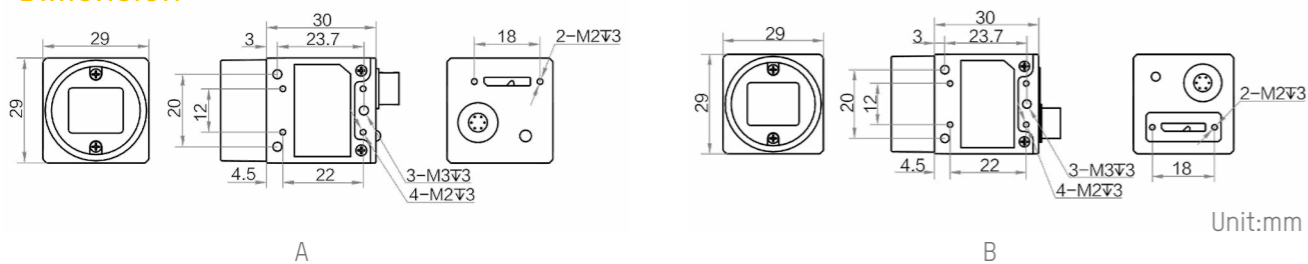

■ CH Series GigE Area Scan Camera

Key Features

- Equipped with excellent image sensor. High dynamic range, superior signal-to-noise ratio and outstanding image quality.
- Implanting powerful ISP algorithms such as bright/dark field correction and lens shadow correction to ensure imaging consistency.
- GigE interface, with maximum transmission distance up to 100m (without relay).
- Class 100 purification process control. Quality control leads in industry.
- Compatible with GigE Vision V2.0 protocol and GenICam standard and seamless connection with third-party softwares.
- CE, FCC, RoHS, KC certification.



Specifications

Model	Sensor model	Sensor size	Pixel size	Shutter mode	Resolution	Max. frame rate	ADC bit depth	Data interface	Mono/Color	Exposure time	Power consumption	Power supply	Working temperature	Lens mount	Dimension	Label
MV-CH089-10GM	IMX267	1"	3.45 μm	Global	4096 × 2160	13 fps	12	GigE	Mono	USE:1 μs-14 μs NE:15 μs-10 sec	Typ. 3.5 W@12 VDC	12 VDC,PoE	0-50°C	C	44 mm × 29 mm × 59 mm	A
MV-CH089-10GC	IMX267	1"	3.45 μm	Global	4096 × 2160	13 fps	12	GigE	Color	USE:1 μs-14 μs NE:15 μs-10 sec	Typ. 3.8 W@12 VDC	12 VDC,PoE	0-50°C	C	44 mm × 29 mm × 59 mm	A
MV-CH120-10GM	IMX304	1.1"	3.45 μm	Global	4096 × 3000	9.4 fps	12	GigE	Mono	USE:1 μs-14 μs NE:15 μs-10 sec	Typ. 4.6 W@12 VDC	12 VDC,PoE	0-50°C	C	44 mm × 29 mm × 59 mm	A
MV-CH120-10GC	IMX304	1.1"	3.45 μm	Global	4096 × 3000	9.4 fps	12	GigE	Color	USE:1 μs-14 μs NE:15 μs-10 sec	Typ. 4.6 W@12 VDC	12 VDC,PoE	0-50°C	C	44 mm × 29 mm × 59 mm	A
MV-CH120-11GM	IMX304	1.1"	3.45 μm	Global	4096 × 3000	9.4 fps	12	GigE	Mono	USE:1 μs-14 μs NE:15 μs-10 sec	Typ. 4.2 W@12 VDC	9-24 VDC,PoE	0-50°C	C	29 mm × 29 mm × 42 mm	B
MV-CH120-20GM	XGS12000	1"	3.2 μm	Global	4096 × 3072	9.6 fps	12	GigE	Mono	USE:52 μs-161 μs NE:162 μs-10 sec	Typ. 3.2 W@12 VDC	9-24 VDC,PoE	0-50°C	C	29 mm × 29 mm × 42 mm	B
MV-CH120-20GC*	XGS12000	1"	3.2 μm	Global	4096 × 3072	9.6 fps	12	GigE	Color	USE:52 μs-161 μs NE:162 μs-10 sec	Typ. 3.2 W@12 VDC	9-24 VDC,PoE	0-50°C	C	29 mm × 29 mm × 42 mm	B
MV-CH250-21GM	PYTHON25K	23 mm × 23 mm	4.5 μm	Global	5120 × 5120	4.64 fps	10	GigE	Mono	NE: 80 μs-10 sec	Typ. 6.7 W@12 VDC	12 VDC	0-50°C	F M58	74 mm × 74 mm × 78.7 mm 74 mm × 74 mm × 72.7 mm	C E
MV-CH250-21GC	PYTHON25K	23 mm × 23 mm	4.5 μm	Global	5120 × 5120	4.64 fps	10	GigE	Color	NE: 80 μs-10 sec	Typ. 6.7 W@12 VDC	12 VDC	0-50°C	F M58	74 mm × 74 mm × 78.7 mm 74 mm × 74 mm × 72.7 mm	C E
MV-CH250-90GM	GMAX0505	1.1"	2.5 μm	Global	5120 × 5120	4.5 fps	12	GigE	Mono	NE:12 μs-10 sec	Typ. 3.6 W@12 VDC	12 VDC,PoE	0-50°C	C	44 mm × 29 mm × 59 mm	A
MV-CH250-90GC	GMAX0505	1.1"	2.5 μm	Global	5120 × 5120	4.5 fps	12	GigE	Color	NE:12 μs-10 sec	Typ. 4.2 W@12 VDC	12 VDC,PoE	0-50°C	C	44 mm × 29 mm × 59 mm	A
MV-CH250-90GN*	GMAX0505	1.1"	2.5 μm	Global	5120 × 5120	4.5 fps	12	GigE	Near-infrared	NE:12 μs-10 sec	Typ. 3.6 W@12 VDC	12 VDC,PoE	0-50°C	C	44 mm × 29 mm × 59 mm	A
MV-CH310-10GM	IMX342	APS-C	3.45 μm	Global	6464 × 4852	3.9 fps	12	GigE	Mono	USE:3 us - 33 us NE:36 μs - 2 S	Typ. 9 W@12 VDC	9-24 VDC,PoE	0-50°C	F M58	74 mm × 74 mm × 80.1 mm 74 mm × 74 mm × 74.3 mm	D F
MV-CH310-10GC	IMX342	APS-C	3.45 μm	Global	6464 × 4852	3.9 fps	12	GigE	Color	USE:3 us - 33 us NE:36 μs - 10 S	Typ. 9W@12 VDC	9-24 VDC,PoE	0-50°C	F M58	74 mm × 74 mm × 80.1 mm 74 mm × 74 mm × 74.3 mm	D F

Notice: * will be released soon.
 USE:Ultra-short exposure mode
 NE:Normal exposure mode

Dimension

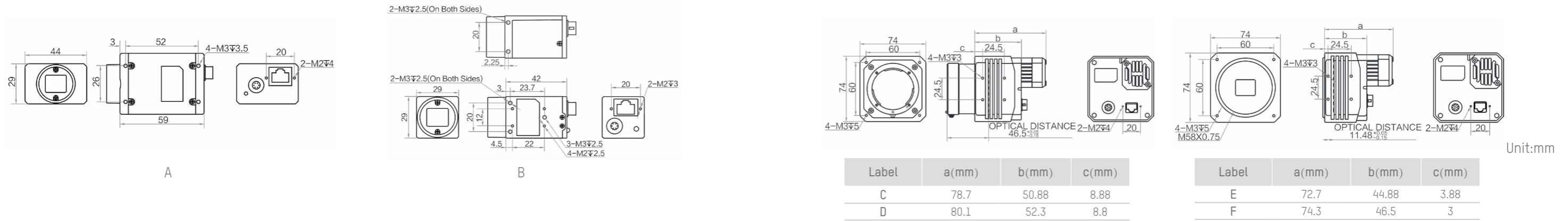

CH Series USB3.0 Area Scan Camera

Key Features

- Equipped with excellent image sensor. High dynamic range, superior signal-to-noise ratio and outstanding image quality.
- Implanting powerful ISP algorithms such as bright/dark field correction and lens shadow correction to ensure imaging consistency.
- Class 100 purification process control. Quality control leads in industry.
- USB 3.0 interface, support USB power supply, body screw holes improve installation stability.
- Compatible with USB3 Vision protocol and GenICam standard and seamless connection with third-party softwares.
- CE, FCC, RoHS, KC certification.



Specifications

Model	Sensor model	Sensor size	Pixel size	Shutter mode	Resolution	Max. frame rate	ADC bit depth	Data interface	Mono/Color	Exposure time	Power consumption	Power supply	Working temperature	Lens mount	Dimension	Label
MV-CH050-10UM	IMX250	2/3"	3.45 μm	Global	2448 × 2048	74 fps	12	USB3.0	Mono	USE:1 μs-14 μs NE:15 μs-10 sec	Typ. 3.5 W@5 VDC	9-24 VDC, USB3.0	0-50°C	C	29 mm × 29 mm × 30 mm	A
MV-CH050-10UC	IMX250	2/3"	3.45 μm	Global	2448 × 2048	74 fps	12	USB3.0	Color	USE:1 μs-14 μs NE:15 μs-10 sec	Typ. 3.5 W@5 VDC	9-24 VDC, USB3.0	0-50°C	C	29 mm × 29 mm × 30 mm	A
MV-CH050-10UP*	IMX250MZR	2/3"	3.45 μm	Global	2448 × 2048	74 fps	12	USB3.0	Polarization	USE:1 μs-14 μs NE:15 μs-10 sec	Typ. 3.5 W@5 VDC	9-24 VDC, USB3.0	0-50°C	C	29mm×29mm×30mm	A
MV-CH089-10UM	IMX267	1"	3.45 μm	Global	4096 × 2160	32 fps	12	USB3.0	Mono	USE:1 μs-14 μs NE:15 μs-10 sec	Typ. 3.27 W@5 VDC	12 VDC,USB3.0	0-50°C	C	44 mm × 29 mm × 59 mm	B
MV-CH089-10UC	IMX267	1"	3.45 μm	Global	4096 × 2160	32 fps	12	USB3.0	Color	USE:1 μs-14 μs NE:15 μs-10 sec	Typ. 3.27 W@5 VDC	12 VDC,USB3.0	0-50°C	C	44 mm × 29 mm × 59 mm	B
MV-CH120-10UM	IMX304	1.1"	3.45 μm	Global	4096 × 3000	23.1 fps	12	USB3.0	Mono	USE:1 μs-14 μs NE:15 μs-10 sec	Typ. 3.5 W@5 VDC	12 VDC,USB3.0	0-50°C	C	44 mm × 29 mm × 59 mm	B
MV-CH120-10UC	IMX304	1.1"	3.45 μm	Global	4096 × 3000	23.1 fps	12	USB3.0	Color	USE:1 μs-14 μs NE:15 μs-10 sec	Typ. 3.5 W@5 VDC	12 VDC,USB3.0	0-50°C	C	44 mm × 29 mm × 59 mm	B
MV-CH120-20UM	XGS12000	1"	3.2 μm	Global	4096 × 3072	28 fps	12	USB3.0	Mono	USE:52 μs-161 μs NE:162 μs-10 sec	Typ. 3.5 W@5 VDC	9-24 VDC, USB3.0	0-50°C	C	29 mm×29 mm×30 mm	C
MV-CH120-20UC*	XGS12000	1"	3.2 μm	Global	4096 × 3072	28 fps	12	USB3.0	Color	USE:52 μs-161 μs NE:162 μs-10 sec	Typ. 3.5 W@5 VDC	9-24 VDC, USB3.0	0-50°C	C	29 mm×29 mm×30 mm	C

Model	Sensor model	Sensor size	Pixel size	Shutter mode	Resolution	Max. frame rate	ADC bit depth	Data interface	Mono/Color	Exposure time	Power consumption	Power supply	Working temperature	Lens mount	Dimension	Label
MV-CH250-90UM*	GMAX0505	1.1"	2.5 μm	Global	5120 × 5120	14.3 fps	12	USB3.0	Mono	NE:12 μs ~ 10 sec	Typ. 3.4 W@12 VDC	9-24 VDC, USB3.0	0-50°C	C	44 mm × 29 mm × 59 mm	B
MV-CH250-90UC*	GMAX0505	1.1"	2.5 μm	Global	5120 × 5120	14.3 fps	12	USB3.0	Color	NE:12 μs ~ 10 sec	Typ. 4 W@12 VDC	9-24 VDC, USB3.0	0-50°C	C	44 mm × 29 mm × 59 mm	B

Notice: * will be released soon.
 USE:Ultra-short exposure mode
 NE:Normal exposure mode

Dimension

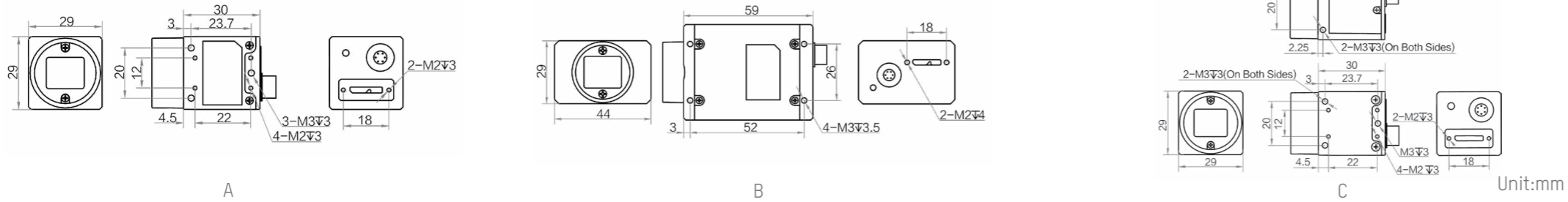

CH Series 10GigE Area Scan Camera

Key Features

- Low-power platform, equipped with excellent image sensor. High dynamic range, superior signal-to-noise ratio and outstanding image quality.
- Implanting powerful ISP algorithms such as bright/dark field correction and lens shadow correction to ensure imaging consistency.
- Class 100 purification process control. Quality control leads in industry.
- The highly cost-effective 10GigE high-speed transmission solution is backward compatible with Gigabit network. Work with Cat 6 or Cat 6a Ethernet cables.
- Compatible with GigE Vision V2.0 protocol and GenICam standard and seamless connection with third-party softwares.
- CE, FCC, RoHS, KC certification.



Specifications

Model	Sensor model	Sensor size	Pixel size	Shutter mode	Resolution	Max. frame rate	ADC bit depth	Data interface	Mono/Color	Exposure time	Power consumption	Power supply	Working temperature	Lens mount	Dimension	Label
MV-CH120-10TM	IMX253	1.1"	3.45 μm	Global	4096 × 3000	68 fps	8/12	10GigE	Mono	2 μs-10 sec	Typ. 11 W@12 VDC	9-24 VDC	0-50°C	M58	Fan:74 mm × 74 mm × 72.4 mm	A
														F	Fan:74 mm × 74 mm × 78.4 mm	D
MV-CH120-10TC*	IMX253	1.1"	3.45 μm	Global	4096 × 3000	68 fps	8/12	10GigE	Color	2 μs-10 sec	Typ. 11 W@12 VDC	9-24 VDC	0-50°C	M58	Fan:74 mm × 74 mm × 72.4 mm	A
														F	Fan:74 mm × 74 mm × 78.4 mm	D
MV-CH120-20TM*	XGS12000	1"	3.2 μm	Global	4096 × 3072	90 fps	12	10GigE	Mono	5 μs-10 sec	Typ. 11 W@12 VDC	9-24 VDC	0-50°C	M58	No fan:84 mm × 84 mm × 62.5 mm	G
														C	No fan:84 mm × 84 mm × 62.5 mm	H
MV-CH120-20TC*	XGS12000	1"	3.2 μm	Global	4096 × 3072	90 fps	12	10GigE	Color	5 μs-10 sec	Typ. 11 W@12 VDC	9-24 VDC	0-50°C	M58	No fan:84 mm × 84 mm × 62.5 mm	G
														C	No fan:84 mm × 84 mm × 62.5 mm	H
MV-CH240-10TM*	IMX540	1.2"	2.74 μm	Global	5328 × 4600	35.1 fps	8/12	10GigE	Mono	1 μs-10 sec	Typ. 10 W@12 VDC	9-24 VDC	0-50°C	M58	No fan:84 mm × 84 mm × 62.5 mm	G
														C	No fan:84 mm × 84 mm × 62.5 mm	H

Model	Sensor model	Sensor size	Pixel size	Shutter mode	Resolution	Max. frame rate	ADC bit depth	Data interface	Mono/Color	Exposure time	Power consumption	Power supply	Working temperature	Lens mount	Dimension	Label
MV-CH250-25TM*	PYTHON25K	23 mm × 23 mm	4.5 μm	Global	5120 × 5120	40 fps	10	10GigE	Mono	45 μs-10 sec	Typ. 14 W@12 VDC	9-24 VDC	0 -50°C	M58	Fan:74mm×74mm×72.7mm	B
														F	Fan:74mm×74mm×78.7mm	E
MV-CH250-25TC*	PYTHON25K	23 mm × 23 mm	4.5 μm	Global	5120 × 5120	40 fps	10	10GigE	Color	45 μs-10 sec	Typ. 13 W@12 VDC	9-24 VDC	0 -50°C	M58	Fan:74mm×74mm×72.7mm	B
														F	Fan:74mm×74mm×78.7mm	E
MV-CH250-90TM*	GMAX0505	1.1"	2.5 μm	Global	5120 × 5120	41.5 fps	12	10GigE	Mono	13 μs - 10 sec	Typ. 10 W@12 VDC	9-24 VDC	0-50°C	M58	Fan:74 mm × 74 mm × 78.8 mm	C
MV-CH250-90TC*	GMAX0505	1.1"	2.5 μm	Global	5120 × 5120	41.5 fps	12	10GigE	Color	13 μs - 10 sec	Typ. 10 W@12 VDC	9-24 VDC	0-50°C	M58	Fan:74 mm × 74 mm × 78.8 mm	C
MV-CH310-10TM*	IMX342	APS-C	3.45 μm	Global	6464 × 4852	17 fps	8/12	10GigE	Mono	4 μs-10 sec	Typ. 15 W@12 VDC	9-24 VDC	0 -50°C	M58	No fan:74mm×74mm×64.4mm	I
MV-CH650-90TM	GMAX3265	29.9 mm × 22.4 mm	3.2 μm	Global	9344 × 7000	15.5 fps	12	10GigE	Mono	15 μs-10 sec	Typ. 11 W@12 VDC	9-24 VDC	0 -50°C	M58	Fan:74 mm × 74 mm × 78.8 mm	C
														F	Fan:74 mm × 74 mm × 84.8 mm	F
MV-CH650-90TC*	GMAX3265	29.9 mm × 22.4 mm	3.2 μm	Global	9344 × 7000	15.5 fps	12	10GigE	Color	15 μs-10 sec	Typ. 11 W@12 VDC	9-24 VDC	0 -50°C	M58	Fan:74 mm × 74 mm × 78.8 mm	C
														F	Fan:74 mm × 74 mm × 84.8 mm	F
MV-CH1510-10FM*	IMX411	66.7 mm	3.76 μm	Rolling	14208 × 10640	6.2 fps	12/16	10GigE	Mono	15 μs-10 sec	TEC off: Typ. 13 W@24 VDC TEC on: Typ. 56 W@24 VDC	9-24 VDC	0 -50°C	M72	TEC:120 mm × 120 mm × 89 mm	J

Notice:Notice: * will be released soon.

Dimension

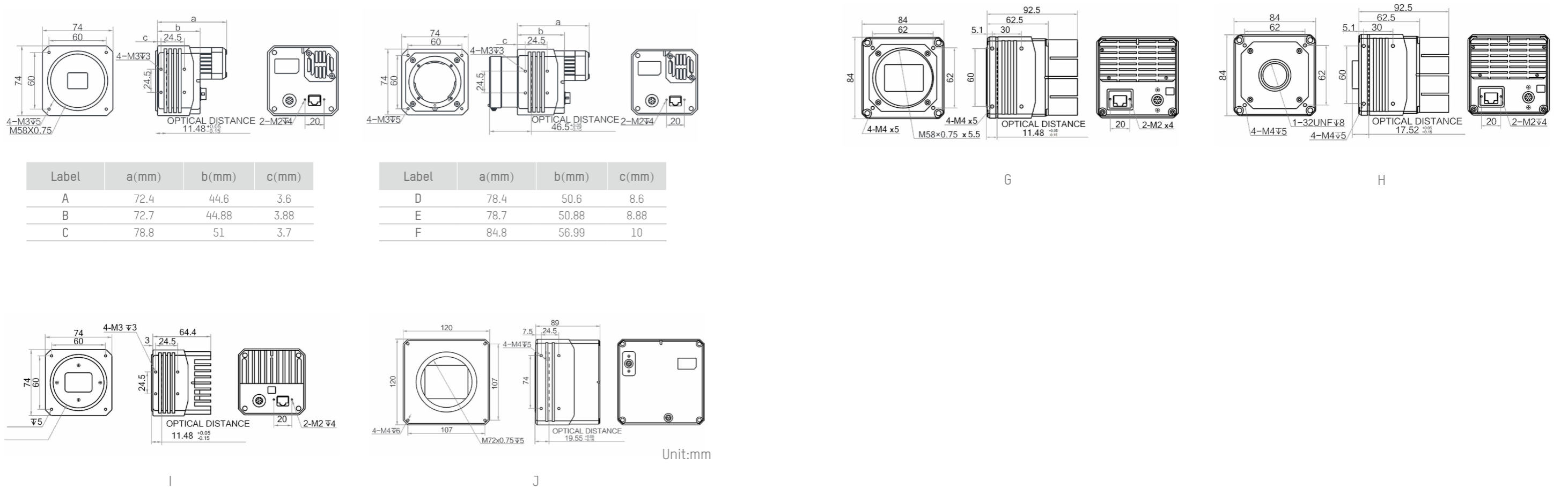

CH Series Camera Link Area Scan Camera

Key Features

- Equipped with excellent image sensor. High dynamic range, superior signal-to-noise ratio and outstanding image quality.
- Implanting powerful ISP algorithms such as bright/dark field correction and lens shadow correction to ensure imaging consistency.
- Class 100 purification process control. Quality control leads in industry.
- Support Base, Medium, Full and 80-bit mode. Pixel clock frequency can be selected to match cables with different transmission distances.
- Compatible with Camera Link protocol and GenICam standard and can be seamlessly connected to third-party software platforms.
- CE, FCC, RoHS, KC certification.



Specifications

Model	Sensor model	Sensor size	Pixel size	Shutter mode	Resolution	Max. frame rate	ADC bit depth	Data interface	Mono/Color	Exposure time	Power consumption	Power supply	Working temperature	Lens mount	Dimension	Label
MV-CH050-10CM	IMX250	2/3"	3.45 μm	Global	2448 × 2048	140 fps	8/12	Camera Link	Mono	4 μs-10 sec	Typ. 3.25 W@12 VDC	9-24 VDC	0-50°C	C	44 mm × 29 mm × 59 mm	A
MV-CH050-11CM	IMX264	2/3"	3.45 μm	Global	2448 × 2048	35 fps	12	Camera Link	Mono	15 μs-10 sec	Typ. 3.25 W@12 VDC	9-24 VDC	0-50°C	C	44 mm × 29 mm × 59 mm	A
MV-CH050-10CC	IMX250	2/3"	3.45 μm	Global	2448 × 2048	140 fps	8/12	Camera Link	Color	4μs-10sec	Typ. 3.25 W@12 VDC	9-24 VDC	0-50°C	C	44 mm × 29 mm × 59 mm	A
MV-CH120-10CM	IMX253	1.1"	3.45 μm	Global	3840 × 3000	69.8 fps	8	Camera Link	Mono	1 μs- 10 sec	Typ. 4.68 W@12 VDC	9-24 VDC	0-50°C	C	44 mm × 29 mm × 59 mm	A
MV-CH120-11CM	IMX304	1.1"	3.45 μm	Global	4096 × 3000	23.4 fps	12	Camera Link	Mono	1 μs-10 sec	Typ. 4.7 W@12 VDC	9-24 VDC	0-50°C	C	44 mm × 29 mm × 59 mm	A
MV-CH120-10CC	IMX253	1.1"	3.45 μm	Global	3840 × 3000	68.1 fps	8	Camera Link	Color	1μs-10sec	Typ. 4.68 W@12 VDC	9-24 VDC	0-50°C	C	44 mm × 29 mm × 59 mm	A
MV-CH250-20CM	PYTHON25K	23 mm × 23 mm	4.5 μm	Global	5120 × 5120	31.3 fps	10	Camera Link	Mono	45 μs-10 sec	Typ. 9.4 W@12 VDC	9-24 VDC	0-50°C	M58	No fan:70 mm × 70 mm × 44.3 mm	B
MV-CH1010-10CM*	IMX461	55 mm	3.76 μm	Rolling	11520 × 8740	8.1 fps	12/16	Camera Link	Mono	14μs-10sec	TEC off: Typ. 14 W@24 VDC TEC on: Typ. 48 W@24 VDC	24 VDC	0-50°C	M72	90 mm × 90 mm × 71.5 mm	C
														M72	TEC:100 mm × 100 mm × 87.2 mm	D

Notice: * will be released soon.

Dimension



Unit:mm

CH Series CoaXPress Area Scan Camera

Key Features

- Low-power platform, equipped with excellent image sensor. High dynamic range, superior signal-to-noise ratio and outstanding image quality.
- Implanting powerful ISP algorithms such as bright/dark field correction and lens shadow correction to ensure imaging consistency.
- Class 100 purification process control. Quality control leads in industry.
- Four-channel CXP-6 or CXP-12 output, ultra-high transmission bandwidth.
- Compatible with CoaXPress protocol and GenICam standard and can be seamlessly connected to third-party software platforms.
- CE, FCC, RoHS, KC certification.



Specifications

Model	Sensor model	Sensor size	Pixel size	Shutter mode	Resolution	Max. frame rate	ADC bit depth	Data interface	Mono/Color	Exposure time	Power consumption	Power supply	Working temperature	Lens mount	Dimension	Label
MV-CH210-90YM*	Gsprint 4521	23.04 mm × 18.43 mm	4.5 μm	Global	5120 × 4096	222 fps	8/12	CXP-12	Mono	NE:9 μs - 10 sec	Typ. 18 W@24 VDC	9-24 VDC	0-50°C	M58	No fan:84 mm × 84 mm × 92.5 mm	A
MV-CH250-20XM*	Python25K	23 mm × 23 mm	4.5 μm	Global	5120 × 5120	80 fps	10	CXP-6	Mono	NE:45 μs-10 sec	Typ. 17 W@24 VDC	9-24 VDC	0-50°C	M58	No fan:84 mm × 84 mm × 92.5 mm	A
MV-CH250-90YM*	GMAX0505	1.1"	2.5 μm	Global	5120 × 5120	150 fps	10	CXP-12	Mono	NE:12 μs - 10 sec	Typ. 13.7 W@12 VDC	9-24 VDC	0-50°C	M58	Fan:80 mm × 80 mm × 80 mm	B
MV-CH250-90YC*	GMAX0505	1.1"	2.5 μm	Global	5120 × 5120	150 fps	10	CXP-12	Color	NE:12 μs - 10 sec	Typ. 13.7 W@12 VDC	9-24 VDC	0-50°C	M58	Fan:80 mm × 80 mm × 80 mm	B
MV-CH310-10XM	IMX342	APS-C	3.45 μm	Global	6464 × 4852	17.9 fps	8/12	CXP-6	Mono	USE:3μs - 33μs ADC 8bit :47μs-2sec ADC 12bit:36μs-2sec	Typ. 9.1 W@12 VDC	9-24 VDC	0-50°C	M58	No fan:74 mm × 74 mm × 69.8 mm	C
MV-CH650-90XM	GMAX3265	29.9 mm × 22.4 mm	3.2 μm	Global	9344 × 7000	31.5 fps	12	CXP-6	Mono	NE:14μs-10sec	Typ. 12W@12 VDC	9-24 VDC	0-50°C	M58	No fan:74 mm × 74 mm × 70.4 mm	D
MV-CH650-90XC*	GMAX3265	29.9 mm × 22.4 mm	3.2 μm	Global	9344 × 7000	31.5 fps	12	CXP-6	Color	NE:14μs-10sec	Typ. 12W@12 VDC	9-24 VDC	0-50°C	M58	No fan:74 mm × 74 mm × 70.4 mm	D
MV-CH650-90YM*	GMAX3265	29.9 mm × 22.4 mm	3.2 μm	Global	9344 × 7000	71 fps	10	CXP-12	Mono	NE:14μs-10sec	Typ. 18W@12 VDC	9-24 VDC	0-50°C	M58	No fan:84 mm × 84 mm × 92.5 mm	A
MV-CH650-90YC*	GMAX3265	29.9 mm × 22.4 mm	3.2 μm	Global	9344 × 7000	71 fps	10	CXP-12	Color	NE:14μs-10sec	Typ. 18W@12 VDC	9-24 VDC	0-50°C	M58	No fan:84 mm × 84 mm × 92.5 mm	A
MV-CH1510-10XM	IMX411	66.7 mm	3.76 μm	Rolling	14208 × 10640	6.2 fps	12/16	CXP-6	Mono	NE: 15 μs - 10 sec	Typ. 17 W@24 VDC	12-24 VDC	0-50°C	M72	Fan:100 mm × 100 mm × 74.3 mm	G
MV-CH1510-10XC*	IMX411	66.7mm	3.76 μm	Rolling	14208 × 10640	6.2 fps	12/16	CXP-6	Color	NE: 15 μs - 10 sec	Typ. 17 W@24 VDC	12-24 VDC	0-50°C	M72	Fan:100 mm × 100 mm × 74.3 mm	G
MV-CH1510-11XM*	IMX411	66.7mm	3.76 μm	Rolling	14208 × 10640	6.2 fps	12/16	CXP-6	Mono	NE: 15 μs - 10 sec	Typ. 55 W@24 VDC	24VDC	0-50°C	M72	TEC:120 mm × 120 mm × 84.6 mm	H
MV-CH1510-11XC*	IMX411	66.7mm	3.76 μm	Rolling	14208 × 10640	6.2 fps	12/16	CXP-6	Color	NE: 15 μs - 10 sec	Typ. 55 W@24 VDC	24VDC	0-50°C	M72	TEC:120 mm × 120 mm × 84.6 mm	H
MV-CH6040-10XM*	IMX411	66.7mm	3.76 μm	Rolling	28416 × 21280	6.2 fps	12/16	CXP-6	Mono	NE: 15 μs-10sec	Typ. 17 W@24 VDC	12-24 VDC	0-50°C	M72	TEC:100 mm × 100 mm × 100 mm	I

Notice: * will be released soon.
 USE:Ultra-short exposure mode
 NE:Normal exposure mode

Dimension

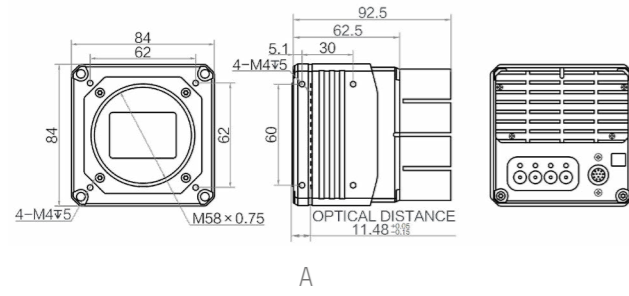

A

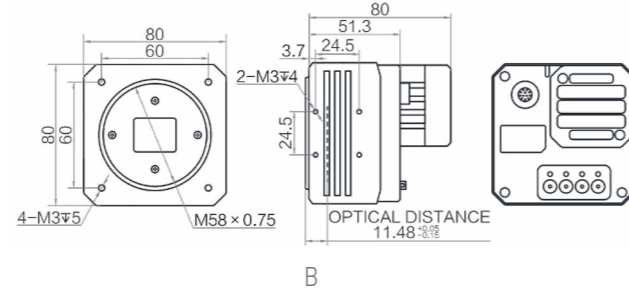

B

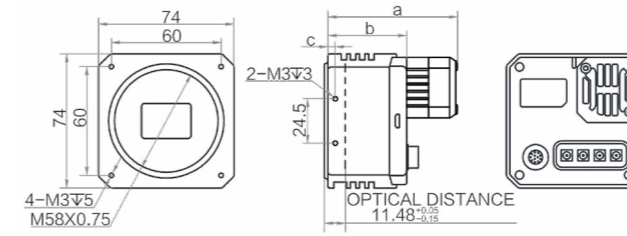

Label	a(mm)	b(mm)	c(mm)
C	69.8	42	3
D	70.4	42.6	3.7

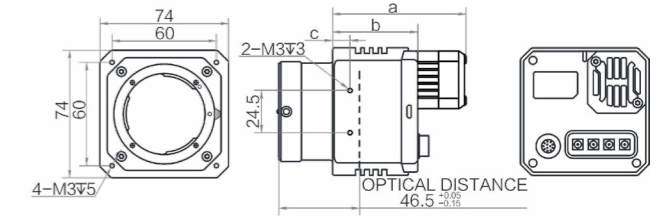

Label	a(mm)	b(mm)	c(mm)
E	75.6	47.8	8.8
F	76.4	48.6	10

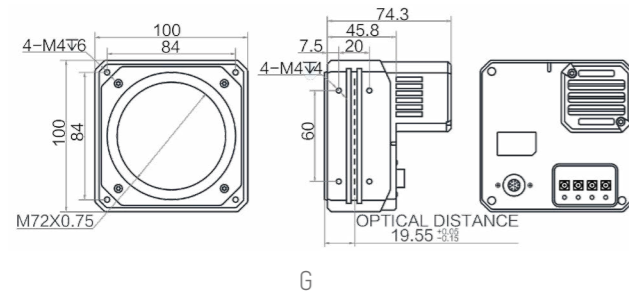

G

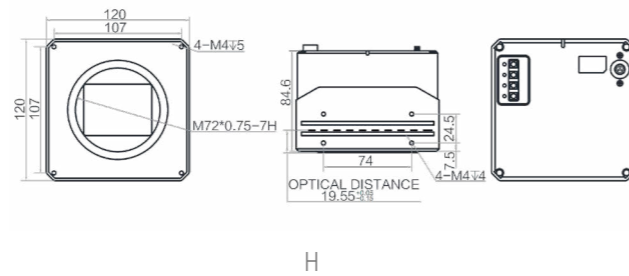

H

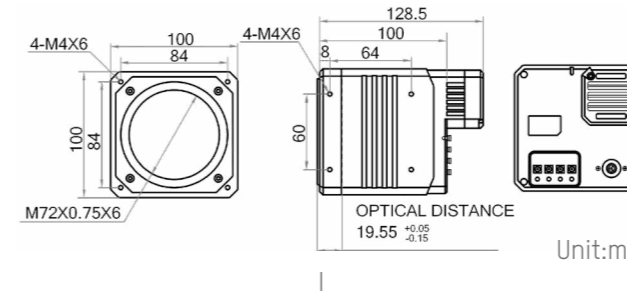

Unit:mm

Line Scan Camera

CL Series GigE Line Scan Camera

Key Features

- Support automatic or manual adjustment of gain, exposure time, etc.
- Support customizing ROI, binning, TDI.
- Support multiple trigger modes, including hardware trigger, software trigger and free run mode.
- Support PRNU and FPN correction.
- Multiple ISP algorithms, ensuring the optimal image quality.
- Compatible with GigE Vision and GenICam standard and can be seamlessly connected to third-party software platforms.
- CE, FCC, RoHS, KC certification.



Specifications

Model	Sensor type	Pixel size	Resolution	Max. line rate	ADC bit depth	Data interface	Mono/Color	Exposure time	Power consumption	Power supply	Working temperature	Lens mount	Dimension	Label
MV-CL021-406M	CMOS	7 μm	2048 × 1	51 kHz	8/10/12	GigE	Mono	2 μs-10 ms	Typ. 4 W @12 VDC	12 VDC,PoE	0-50°C	M42	62 mm × 62 mm × 37.5 mm	A
MV-CL022-406C	CMOS	7 μm	2048 × 2	32 kHz	8/10/12	GigE	Color	2 μs-10 ms	Typ. 4 W @12 VDC	12 VDC,PoE	0-50°C	M42	62 mm × 62 mm × 37.5 mm	A
MV-CL022-916M	CMOS	14 μm	2048×1	100 kHz(@HB)	8/10/12	GigE	Mono	5 μs-10 ms	Typ. 5 W @12 VDC	12-24 VDC,PoE	-20-55°C	M42	62 mm × 62 mm × 41 mm	B
MV-CL022-916C	CMOS	14 μm	2048 × 2	50 kHz(@HB)	8/10/12	GigE	Color	5 μs-10 ms	Typ. 7.4 W @12 VDC	12-24 VDC,PoE	-20-55°C	M42	62 mm × 62 mm × 41 mm	B
MV-CL042-916M	CMOS	7 μm	4096 × 2	80 kHz@HB	8/10/12	GigE	Mono	5 μs-10 ms	Typ. 5.8 W @12 VDC	12-24 VDC,PoE	-20-55°C	M42	62 mm × 62 mm × 41 mm	B
MV-CL042-916C	CMOS	7 μm	4096 × 2	40kHz@HB	8/10/12	GigE	Color	5 μs-10 ms	Typ. 6.6 W @12 VDC	12-24 VDC,PoE	-20-55°C	M42	62 mm × 62 mm × 41 mm	B
MV-CL084-916M	CMOS	5 μm	8192 × 4	40 kHz@HB	8/10/12	GigE	Mono	3 μs-10 ms	Typ. 12.4 W @12 VDC	12-24 VDC	-20-55°C	M72	80 mm × 80 mm × 46.3 mm	C
MV-CL086-916C	CMOS	5 μm	8192 × 6	40 kHz@HB	8/10	GigE	Color	3 μs-10 ms	Typ. 13 W @12 VDC	12-24 VDC	-20-55°C	M72	80 mm × 80 mm × 46.3 mm	C

Notice: * will be released soon.

Dimension

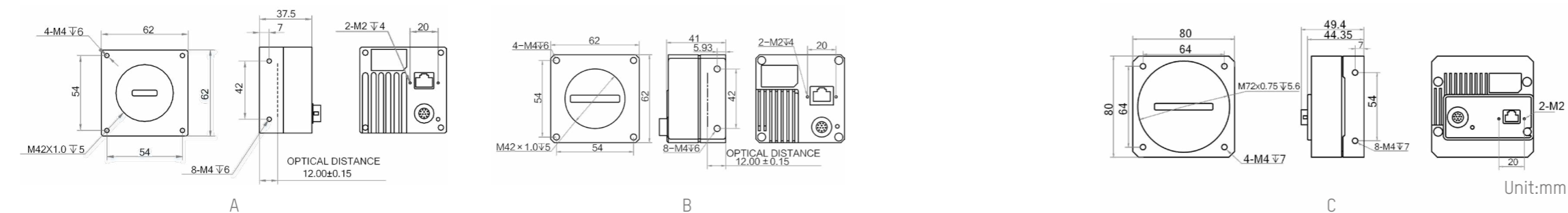

CL Series Camera Link Line Scan Camera

Key Features

- Support automatic or manual adjustment of gain, exposure time, etc.
- Support customizing ROI, binning, TDI.
- Support multiple trigger modes, including hardware trigger, software trigger and free run mode.
- Support PRNU and FPN correction.
- Multiple ISP algorithms, ensuring the optimal image quality.
- Compatible with Camera Link protocol and GenICam standard and can be seamlessly connected to third-party software platforms.
- CE, FCC, RoHS, KC certification.



Specifications

Model	Sensor type	Pixel size	Resolution	Max. line rate	ADC bit depth	Data interface	Mono/Color	Exposure time	Power consumption	Power supply	Working temperature	Lens mount	Dimension	Label
MV-CL042-91CM	CMOS	7 μm	4096 × 2	100kHz	8/10/12	Camera Link	Mono	5 μs-10 ms	Typ. 5.5 W @12 VDC	12 ~ 24 VDC	-20-55°C	M42	62 mm × 62 mm × 36.9 mm	A
MV-CL042-91CC	CMOS	7 μm	4096 × 2	100kHz	8	Camera Link	Color	5 μs-10 ms	Typ. 6.1 W @12 VDC	12 ~ 24 VDC	-20-55°C	M42	62 mm × 62 mm × 36.9 mm	A
MV-CL084-90CM	CMOS	5 μm	8192 × 4	100kHz	8/10/12	Camera Link	Mono	3 μs-10 ms	Typ. 12.3 W @12 VDC	12 ~ 24 VDC	0-50°C	M72	150 mm × 80 mm × 23.8 mm	B
MV-CL086-90CC	CMOS	5 μm	8192 × 6	34kHz	8	Camera Link	Color	3 μs-10 ms	Typ. 12.3 W @12 VDC	12 ~ 24 VDC	0-50°C	M72	150 mm × 80 mm × 23.8 mm	B
MV-CL084-91CM*	CMOS	5 μm	8192 × 4	100kHz	8/10	Camera Link	Mono	3 μs-10 ms	Typ. 20 W @24 VDC	24 VDC	-10-50°C	M72	84 mm × 84 mm × 89 mm	C
MV-CL088-91CC*	CMOS	5 μm	8192 × 8	34kHz	8/10	Camera Link	Color	3 μs-10 ms	Typ. 22 W @24 VDC	24 VDC	-10-50°C	M72	84 mm × 84 mm × 89 mm	C

Notice: * will be released soon.

Dimension

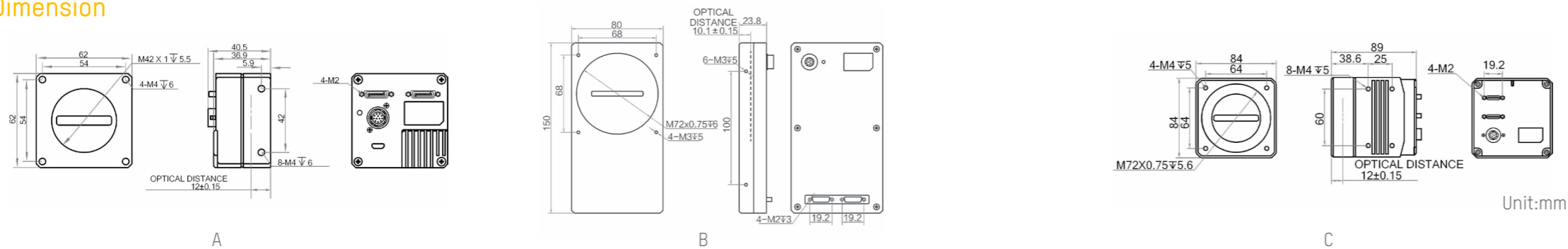

Board Level Camera

CB Series GigE Board Level Camera

Key Features

- Multi-board design. Support flexible installation and configuration.
- Support access to mainstream embedded development boards for quick secondary development.
- Compact structure, bare board, C interface, M12 interface are available.
- Gige ethernet interface, support PoE.
- Compatible with machine vision standard protocols and GenICam standard, seamless connection to third-party software platforms.

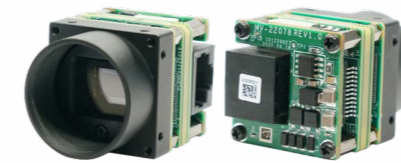

Specifications

Model	Sensor model	Sensor size	Pixel size	Shutter mode	Resolution	Max. frame rate	bit depth	Data interface	Mono/Color	Exposure time	Power consumption	Power supply	Working temperature	Lens mount	Dimension	Label
MV-CB004-10GM-C	IMX297	1/2.9"	6.9 μm	Global	720 × 540	125.2 fps	10 bit	GigE	Mono	USE:1 μs-14 μs NE:15 μs-10 sec	Typ. 2.5 W@12 VDC	9-24 VDC,PoE	0-50°C	C	29 mm × 29 mm × 30.2 mm	A
MV-CB004-10GM-S	IMX297	1/2.9"	6.9 μm	Global	720 × 540	125.2 fps	10 bit	GigE	Mono	USE:1 μs-14 μs NE:15 μs-10 sec	Typ. 2.5 W@12 VDC	9-24 VDC,PoE	0-50°C	M12	29 mm × 29 mm × 30.2 mm	B
MV-CB004-10GC-C	IMX297	1/2.9"	6.9 μm	Global	720 × 540	125.2 fps	10 bit	GigE	Color	USE:1 μs-14 μs NE:15 μs-10 sec	Typ. 2.5 W@12 VDC	9-24 VDC,PoE	0-50°C	C	29 mm × 29 mm × 30.2 mm	A
MV-CB004-10GC-S	IMX297	1/2.9"	6.9 μm	Global	720 × 540	125.2 fps	10 bit	GigE	Color	USE:1 μs-14 μs NE:15 μs-10 sec	Typ. 2.5 W@12 VDC	9-24 VDC,PoE	0-50°C	M12	29 mm × 29 mm × 30.2 mm	B
MV-CB016-10GM-C	IMX296	1/2.9"	3.45 μm	Global	1440 × 1080	65.2 fps	10 bit	GigE	Mono	USE:1 μs-14 μs NE:15 μs-10 sec	Typ. 2.6 W@12 VDC	9-24 VDC,PoE	0-50°C	C	29 mm × 29 mm × 30.2 mm	A
MV-CB016-10GM-S	IMX296	1/2.9"	3.45 μm	Global	1440 × 1080	65.2 fps	10 bit	GigE	Mono	USE:1 μs-14 μs NE:15 μs-10 sec	Typ. 2.6 W@12 VDC	9-24 VDC,PoE	0-50°C	M12	29 mm × 29 mm × 30.2 mm	B
MV-CB016-10GC-C	IMX296	1/2.9"	3.45 μm	Global	1440 × 1080	65.2 fps	10 bit	GigE	Color	USE:1 μs-14 μs NE:15 μs-10 sec	Typ. 2.7 W@12 VDC	9-24 VDC,PoE	0-50°C	C	29 mm × 29 mm × 30.2 mm	A
MV-CB016-10GC-S	IMX296	1/2.9"	3.45 μm	Global	1440 × 1080	65.2 fps	10 bit	GigE	Color	USE:1 μs-14 μs NE:15 μs-10 sec	Typ. 2.7 W@12 VDC	9-24 VDC,PoE	0-50°C	M12	29 mm × 29 mm × 30.2 mm	B
MV-CB060-10GM-C	IMX178	1/1.8"	2.4 μm	Rolling	3072 × 2048	30.7 fps	12 bit	GigE	Mono	NE:25 μs-2.5 sec	Typ. 2.3 W@12 VDC	9-24 VDC,PoE	0-50°C	C	29 mm × 29 mm × 30.2 mm	A
MV-CB060-10GM-S	IMX178	1/1.8"	2.4 μm	Rolling	3072 × 2048	30.7 fps	12 bit	GigE	Mono	NE:25 μs-2.5 sec	Typ. 2.3 W@12 VDC	9-24 VDC,PoE	0-50°C	M12	29 mm × 29 mm × 30.2 mm	B
MV-CB060-10GC-C	IMX178	1/1.8"	2.4 μm	Rolling	3072 × 2048	30.7 fps	12 bit	GigE	Color	NE:25 μs-2.5 sec	Typ. 2.6 W@12 VDC	9-24 VDC,PoE	0-50°C	C	29 mm × 29 mm × 30.2 mm	A
MV-CB060-10GC-S	IMX178	1/1.8"	2.4 μm	Rolling	3072 × 2048	30.7 fps	12 bit	GigE	Color	NE:25 μs-2.5 sec	Typ. 2.6 W@12 VDC	9-24 VDC,PoE	0-50°C	M12	29 mm × 29 mm × 30.2 mm	B

Notice:USE:Ultra-short exposure mode
NE:Normal exposure mode

Dimension

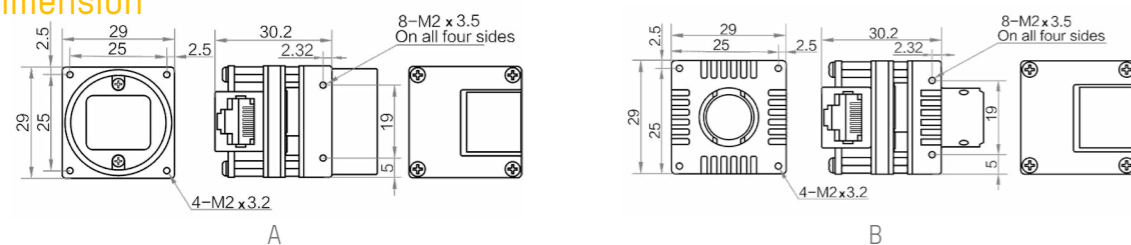

Unit:mm

CB Series USB3.0 Board Level Camera

Key Features

- Single-board simplified design. Support flexible installation and configuration.
- Support access to mainstream embedded development boards for quick secondary development.
- Compact structure, bare board, C interface, M12 interface are available.
- USB3.0 interface, support USB interface power supply, low power consumption.
- Compatible with machine vision standard protocols and GenICam standard, seamless connection to third-party software platforms.

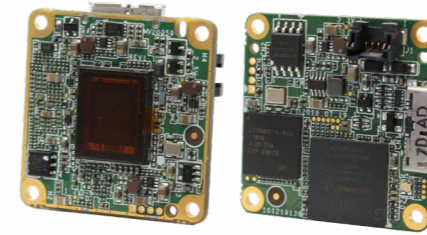

Specifications

Model	Sensor model	Sensor size	Pixel size	Shutter mode	Resolution	Max. frame rate	Bit depth	Data interface	Mono/Color	Exposure time	Power consumption	Power supply	Working temperature	Lens mount	Dimension	Label
MV-CB013-20UM-B	PYTHON1300	1/2"	4.8 μm	Global	1280 × 1024	170 fps	10	USB3.0	Mono	40 μs-10 sec	Typ. 2.28 W@5 VDC	USB3.0	0-50°C	none	32.5 mm×32.5 mm×1.6 mm	A
MV-CB013-20UM-C	PYTHON1300	1/2"	4.8 μm	Global	1280 × 1024	170 fps	10	USB3.0	Mono	40 μs-10 sec	Typ. 2.28 W@5 VDC	USB3.0	0-50°C	C mount	35 mm×35 mm×8.6 mm	B
MV-CB013-20UM-S	PYTHON1300	1/2"	4.8 μm	Global	1280 × 1024	170 fps	10	USB3.0	Mono	40 μs-10 sec	Typ. 2.28 W@5 VDC	USB3.0	0-50°C	M12	35 mm×35 mm×8.6 mm	C
MV-CB013-20UC-B	PYTHON1300	1/2"	4.8 μm	Global	1280 × 1024	170 fps	10	USB3.0	Color	65 μs-10 sec	Typ. 2.28 W@5 VDC	USB3.0	0-50°C	none	32.5 mm×32.5 mm×1.6mm	A
MV-CB013-20UC-C	PYTHON1300	1/2"	4.8 μm	Global	1280 × 1024	170 fps	10	USB3.0	Color	65 μs-10 sec	Typ. 2.28 W@5 VDC	USB3.0	0-50°C	C mount	35 mm×35 mm×8.6 mm	B
MV-CB013-20UC-S	PYTHON1300	1/2"	4.8 μm	Global	1280 × 1024	170 fps	10	USB3.0	Color	65 μs-10 sec	Typ. 2.28 W@5 VDC	USB3.0	0-50°C	M12	35 mm×35 mm×8.6 mm	C
MV-CB060-10UM-B	IMX178	1/1.8"	2.4 μm	Rolling	3072 × 2048	17 fps	12	USB3.0	Mono	27 μs-2.5 sec	Typ. 2.0 W@5 VDC	USB3.0	0-50°C	none	32.5 mm×32.5 mm×1.6 mm	A
MV-CB060-10UM-C	IMX178	1/1.8"	2.4 μm	Rolling	3072 × 2048	17 fps	12	USB3.0	Mono	27 μs-2.5 sec	Typ. 2.0 W@5 VDC	USB3.0	0-50°C	C mount	35 mm×35 mm×8.6 mm	B
MV-CB060-10UM-S	IMX178	1/1.8"	2.4 μm	Rolling	3072 × 2048	17 fps	12	USB3.0	Mono	27 μs-2.5 sec	Typ. 2.0 W@5 VDC	USB3.0	0-50°C	M12	35 mm×35 mm×8.6 mm	C
MV-CB060-10UC-B	IMX178	1/1.8"	2.4 μm	Rolling	3072 × 2048	29 fps	12	USB3.0	Color	16 μs-2.5 sec	Typ. 2.0 W@5 VDC	USB3.0	0-50°C	none	32.5 mm×32.5 mm×1.6mm	A
MV-CB060-10UC-C	IMX178	1/1.8"	2.4 μm	Rolling	3072 × 2048	29 fps	12	USB3.0	Color	16 μs-2.5 sec	Typ. 2.0 W@5 VDC	USB3.0	0-50°C	C mount	35 mm×35 mm×8.6 mm	B
MV-CB060-10UC-S	IMX178	1/1.8"	2.4 μm	Rolling	3072 × 2048	29 fps	12	USB3.0	Color	16 μs-2.5 sec	Typ. 2.0 W@5 VDC	USB3.0	0-50°C	M12	35 mm×35 mm×8.6 mm	C
MV-CB120-10UM-B	IMX226	1/1.7"	1.85 μm	Rolling	4032 × 3036	28 fps	10	USB3.0	Mono	11 μs-2 sec	Typ. 2.45 W@5 VDC	USB3.0	0-50°C	none	32.5 mm×32.5 mm×1.6mm	A
MV-CB120-10UM-C	IMX226	1/1.7"	1.85 μm	Rolling	4032 × 3036	28 fps	10	USB3.0	Mono	11 μs-2 sec	Typ. 2.45 W@5 VDC	USB3.0	0-50°C	C mount	35 mm×35 mm×8.6 mm	B
MV-CB120-10UM-S	IMX226	1/1.7"	1.85 μm	Rolling	4032 × 3036	28 fps	10	USB3.0	Mono	11 μs-2 sec	Typ. 2.45 W@5 VDC	USB3.0	0-50°C	M12	35 mm×35 mm×8.6 mm	C
MV-CB120-10UC-B	IMX226	1/1.7"	1.85 μm	Rolling	4032 × 3036	21 fps	10	USB3.0	Color	23 μs-2 sec	Typ. 2.45 W@5 VDC	USB3.0	0-50°C	none	32.5 mm×32.5 mm×1.6mm	A
MV-CB120-10UC-C	IMX226	1/1.7"	1.85 μm	Rolling	4032 × 3036	21 fps	10	USB3.0	Color	23 μs-2 sec	Typ. 2.45 W@5 VDC	USB3.0	0-50°C	C mount	35 mm×35 mm×8.6 mm	B
MV-CB120-10UC-S	IMX226	1/1.7"	1.85 μm	Rolling	4032 × 3036	21 fps	10	USB3.0	Color	23 μs-2 sec	Typ. 2.45 W@5 VDC	USB3.0	0-50°C	M12	35 mm×35 mm×8.6 mm	C

Dimension

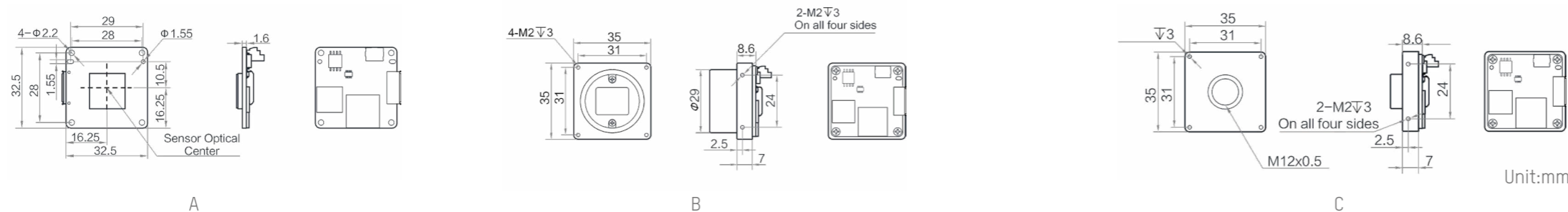

Smart Camera

SC7000 Series Smart Camera

Key Features

- Built-in DL based visual tools, implementing character recognition, object recognition, item sorting, etc.
- Support semi-automatic focusing to realize the production of products in multiple sizes with one equipment.
- Mass storage supported, selectively store device logs and classified pictures.
- A variety of light sources are available for selection to adapt to different production environments.
- Rich IO interfaces provide access for multiple input and output signals.
- Multiple LED indicators indicating realtime status for debugging and maintenance.
- Support multiple communication modes, including Gigabit Ethernet, serial port, TCP, UDP, ftp, EtherNet/IP, Modbus, Profinet, etc.
- CE, FCC, KC certification.



Specifications

Model	Vision tool	Pixel size	Sensor size	Resolution	Max. frame rate	Data interface	Mono/Color	Power Supply	Max. power consumption	Lens mount	Focal length	Lens cap	Light source	Working temperature	Dimension	Label
MV-SC7016C	Feature matching, fixture, blob, color conversion, DL character recognition, DL character location, DL classification, DL object detection, etc.	3.45 μm × 3.45 μm	1/2.9"	1408 × 1024	60 fps	GigE	Color	12-24 VDC	Approx. 18 W@24 VDC	M12	12/15 mm	Transparent, Polarization is optional	White, Red/Blue/ NIR is optional	0 - 50 °C	118.7 mm × 78 mm × 73.2 mm	A
MV-SC7060M	Feature matching, fixture, blob, DL character recognition, DL character location, DL classification, DL object detection, etc.	2.4 μm × 2.4 μm	1/1.8"	3072 × 2048	30 fps	GigE	Mono	12-24 VDC	Approx. 18 W@24 VDC	M12	12 mm	Transparent, Polarization is optional	White, Red/Blue/ NIR is optional	0 - 50 °C	118.7 mm × 78 mm × 73.2 mm	A
MV-SC7060M-00C-NNN	Feature matching, fixture, blob, DL character recognition, DL character location, DL classification, DL object detection, etc.	2.4 μm × 2.4 μm	1/1.8"	3072 × 2048	30 fps	GigE	Mono	12-24 VDC	Approx. 7.5 W@24 VDC	M12	/	Transparent, Polarization is optional	White, Red/Blue/ NIR is optional	0 - 50 °C	109.5 mm × 64.4 mm × 94 mm	B

Dimension

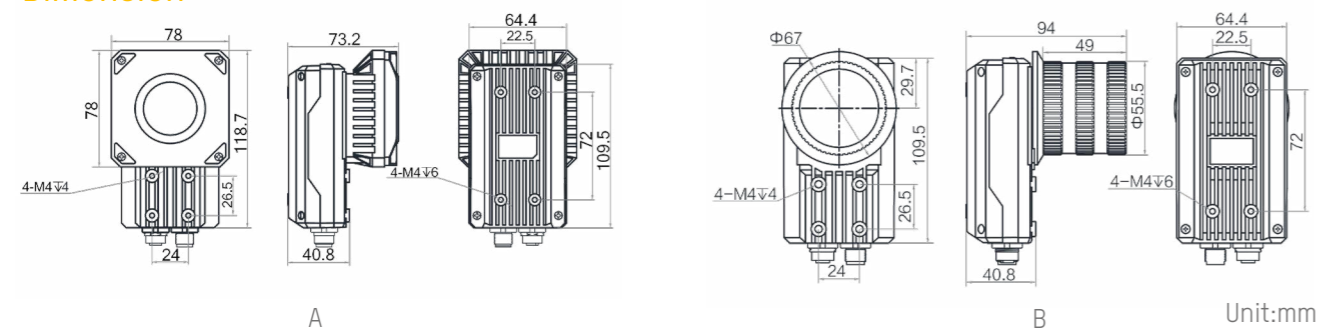

■ SC3000 Series Smart Camera

Key Features

- Using embedded hardware platform, high-speed image processing can be carried out.
- Implant high-precision positioning and measurement algorithms, which can detect presence, front and back, position, size, etc.
- Rich IO interface, can access multiple input and output signals.
- Abundant status indicators, real-time grasp of equipment status, convenient for debugging and maintenance.
- The light source lamp cup is ingeniously designed to ensure uniform brightness in the lighting area.
- Support mechanical focusing, easy on-site debugging.
- Support multiple communication modes, such as serial port, TCP, UDP, FTP, EtherNet/IP, Modbus, Profinet, etc.
- CE, FCC, KC certification.



Specifications

Model	Vision tool	Pixel size	Sensor size	Resolution	Max. frame rate	Ethernet	Mono/Color	Power Supply	Max. power consumption	Lens mount	Focal length	Lens cap	Light source	Working temperature	Dimension
MV-SC3004M	Existence: Pattern existence, spot existence, edge existence, circle existence, line existence Count: Pattern count, spot count, edge count Measurement: Brightness analysis, contrast measurement, greyscale size, diameter measurement, width measurement, line angle, line to line angle, point to line measurement Recognition: OCR, barcode recognition	6.9 μm × 6.9 μm	1/2.9"	704 × 540	100 fps	Fast Ethernet	Mono	12-24VDC	Approx.8.6W@12 VDC	M12	6/12/15 mm	Transparent, Polarization is optional	14 LED: White/Red/Blue/NIR	0-50 °C	65.2 mm × 65.2 mm × 42 mm
MV-SC3004C	Existence: Pattern existence, spot existence, edge existence, circle existence, line existence Count: Pattern count, spot count, edge count Measurement: Brightness analysis, contrast measurement, greyscale size, diameter measurement, width measurement, line angle, line to line angle, point to line measurement, color size Recognition: OCR, color contrast, barcode recognition	6.9 μm × 6.9 μm	1/2.9"	704 × 540	100 fps	Fast Ethernet	Color	12-24VDC	Approx.8.6W@12 VDC	M12	6/12/15 mm	Transparent, Polarization is optional	14 LED: White/Red/Blue/NIR	0-50 °C	65.2 mm × 65.2 mm × 42 mm
MV-SC3016M	Existence: Pattern existence, spot existence, edge existence, circle existence, line existence Count: Pattern count, spot count, edge count Measurement: Brightness analysis, contrast measurement, greyscale size, diameter measurement, width measurement, line angle, line to line angle, point to line measurement Recognition: OCR, barcode recognition	3.45 μm × 3.45 μm	1/2.9"	1408 × 1024	60 fps	Fast Ethernet	Mono	12-24VDC	Approx. 8.6W@12 VDC	M12	6/12/15 mm	Transparent, Polarization is optional	8 LED: White/Red/Blue/NIR	0-50 °C	65.2 mm × 65.2 mm × 42 mm

Model	Vision tool	Pixel size	Sensor size	Resolution	Max. frame rate	Ethernet	Mono/Color	Power Supply	Max. power consumption	Lens mount	Focal length	Lens cap	Light source	Working temperature	Dimension
MV-SC3016C	Existence: Pattern existence, spot existence, edge existence, circle existence, line existence Count: Pattern count, spot count, edge count Measurement: Brightness analysis, contrast measurement, greyscale size, diameter measurement, width measurement, line angle, line to line angle, point to line measurement, color size Recognition: OCR, color contrast, barcode recognition	3.45 μm × 3.45 μm	1/2.9"	1408×1024	60 fps	Fast Ethernet	Color	12-24VDC	Approx. 8.6W@12 VDC	M12	6/12/15 mm	Transparent, Polarization is optional	14 LED: White/Red/Blue/NIR	0-50 °C	65.2 mm × 65.2 mm × 42 mm

Dimension

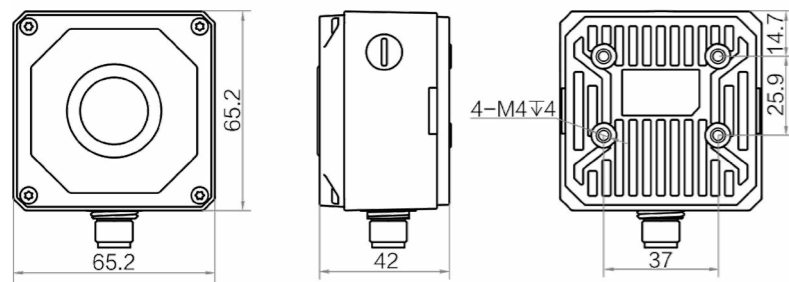

Unit:mm

■ SC2000E Series Vision Sensor

Key Features

- Using embedded hardware platform, high-speed image processing can be carried out.
- Implant high-precision positioning and measurement algorithms, which can detect presence, positive and negative, etc.
- Rich IO interface, can access multiple input and output signals.
- Abundant status indicators, real-time grasp of equipment status, convenient for debugging and maintenance.
- The light source lamp cup is ingeniously designed to ensure uniform brightness in the lighting area.
- Small size, no fear of small spaces.
- Support multiple communication modes, such as serial port, TCP, UDP, FTP, EtherNet/IP, Modbus, Profinet, etc.
- CE, FCC, KC certification.



Specifications

Model	Vision tool	Pixel size	Sensor size	Resolution	Max. frame rate	Ethernet	Mono/Color	Power Supply	Max. power consumption	Lens mount	Focal length	Lens cap	Light source	Working temperature	Dimension
MV-SC2004EM	Existence: Pattern existence, spot existence Count: Pattern count, spot count Measurement: Brightness analysis, contrast measurement	6.9 μm × 6.9 μm	1/2.9"	704 × 540	30 fps	Fast Ethernet	Mono	12-24 VDC	Approx.9.9 W@24 VDC	M12	6 mm	Transparent	White/Red/Blue	0-50 °C	46 mm × 38 mm × 25 mm
MV-SC2016EM	Existence: Pattern existence, spot existence Count: Pattern count, spot count Measurement: Brightness analysis, contrast measurement	3.45 μm × 3.45 μm	1/2.9"	1408 × 1024	30 fps	Fast Ethernet	Mono	12-24 VDC	Approx.9.9 W@24 VDC	M12	6 mm	Transparent	White/Red/Blue	0-50 °C	46 mm × 38 mm × 25 mm

Dimension

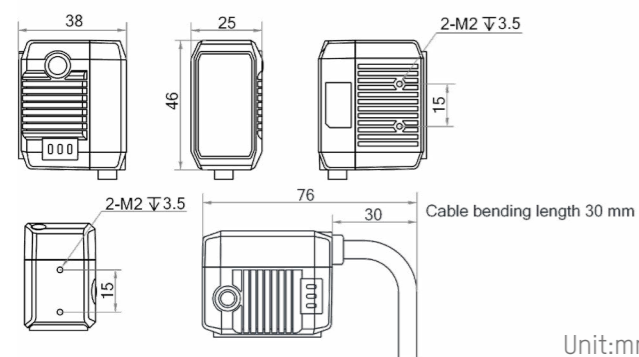

Open Platform Smart Camera

Key Features

- Excellent sensor platform for high-speed image data acquisition.
- Open platform for users to develop their own application based systems.
- Rich IO interfaces provide access for multiple input and output signals.
- Provide multiple trigger modes adapted to diversified application scenarios.
- Multiple LED indicators indicating realtime status to assist the configuration and debugging on site.
- Support expansion interface expansion to response different application requirements.
- CE, FCC, RoHS certification.



Specifications

Model	Sensor model	Pixel size	Sensor size	Resolution	Max. frame rate	Data interface	Mono/Color	Power Supply	Max. power consumption	Lens mount	Lens cap	Light source	Working temperature	Dimension
MV-SI608-386M	PYTHON1300	4.8 μm × 4.8 μm	1/2"	1280 × 1024	80 fps	GigE	Mono	9-24 VDC	Approx.24 W@24 VDC	C	Transparent	White	0-50 °C	126 mm × 66 mm × 113.2 mm
MV-SI608-386C	PYTHON1300	4.8 μm × 4.8 μm	1/2"	1280 × 1024	80 fps	GigE	Color	9-24 VDC	Approx.24 W@24 VDC	C	Transparent	White	0-50 °C	126 mm × 66 mm × 113.2 mm
MV-SI618-086M	PYTHON2000	4.8 μm × 4.8 μm	2/3"	1920 × 1200	50 fps	GigE	Mono	9-24 VDC	Approx.24 W@24 VDC	C	Transparent	White	0-50 °C	126 mm × 66 mm × 113.2 mm
MV-SI628-386M	PYTHON5000	4.8 μm × 4.8 μm	1"	2592 × 2048	30 fps	GigE	Mono	9-24 VDC	Approx.34 W@24 VDC	C	Transparent	White	0-50 °C	126 mm × 66 mm × 113.2 mm
MV-SI628-386C	PYTHON5000	4.8 μm × 4.8 μm	1"	2592 × 2048	30 fps	GigE	Color	9-24 VDC	Approx.34 W@24 VDC	C	Transparent	White	0-50 °C	126 mm × 66 mm × 113.2 mm
MV-SI638-086M	IMX178	2.4 μm × 2.4 μm	1/1.8"	3072 × 2048	17 fps	GigE	Mono	9-24 VDC	Approx.34 W@24 VDC	C	Transparent	White	0-50 °C	126 mm × 66 mm × 113.2 mm
MV-SI638-086C	IMX178	2.4 μm × 2.4 μm	1/1.8"	3072 × 2048	17 fps	GigE	Color	9-24 VDC	Approx.34 W@24 VDC	C	Transparent	White	0-50 °C	126 mm × 66 mm × 113.2 mm
MV-SI648-086M	IMX267	3.45 μm × 4.8 μm	1"	4096 × 2160	11 fps	GigE	Mono	9-24 VDC	Approx.24 W@24 VDC	C	Transparent	White	0-50 °C	126 mm × 66 mm × 113.2 mm

Dimension

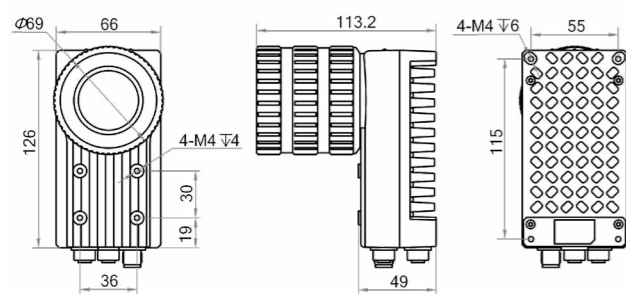

Unit:mm

Smart Code Reader

ID2000 Series Smart Code Reader

Key Features

- Ultra-small structure, suitable for various types of machines and compact workstations.
- Support reading multiple codes, such as Code 39, Code 93, Code 128, CodaBar, EAN, ITF25, QR, DM, etc.
- Using high-speed solid-state focusing lens technology, focus adjustment can be completed quickly within 5ms.
- Design multi-color LED light source, adopt asymmetrical arrangement, and cover more evenly.
- Aviation plug design, single cable connection, easy wiring.
- Built-in LED sight, clearly indicating the field of view, quick installation and adjustment.
- Front waterproof debugging button, and support external hands-on trigger.
- Abundant IO interface and direct plug-in power interface, convenient for wiring.



Specifications

Model	Sensor size	Pixel size	Resolution	Frame rate	Reading speed	Focal Length	Working distance	Client software	Ethernet	Power Supply	Max. power consumption	Light source	Aiming system	Working temperature	Dimension	Label
MV-ID2004M-06S-xBN	1/2.9"	6.9 μm × 6.9 μm	704 × 540	60 fps	41 codes/sec	6 mm	40-120 mm, manual focus	IDMVS	Fast Ethernet	12 - 24 VDC	Approx.10.6 W@24 VDC	White/Red/Blue	Green LED	0 - 50 °C	46 mm × 38 mm × 25 mm	A
MV-ID2004M-06S-xBN-U	1/2.9"	6.9 μm × 6.9 μm	704 × 540	60 fps	38 codes/sec	6 mm	40-120 mm, manual focus	IDMVS	USB3.0	5 V,USB3.0	Approx.4.6 W@5 VDC	White/Red/Blue	Green LED	0 - 50 °C	46 mm × 38 mm × 25 mm	A
MV-ID2010M-05M-WLR*	1/4"	3 μm × 3 μm	1280 × 800	20 fps	36 codes/sec	5 mm	/	IDMVS	Fast Ethernet	12 - 24 VDC	Approx.1.6 W@24 VDC	White	Cross laser	0 - 50 °C	46 mm × 38 mm × 25 mm	B
MV-ID2016M-06S-xBN*	1/2.9"	3.45 μm × 3.45 μm	1408 × 1024	60 fps	29 codes/sec	6 mm	40-120 mm, manual focus	IDMVS	Fast Ethernet	12 - 24 VDC	Approx.10.6 W@24 VDC	White/Red/Blue	Green LED	0 - 50 °C	46 mm × 38 mm × 25 mm	A
MV-ID2016M-06S-xBN-U*	1/2.9"	3.45 μm × 3.45 μm	1408 × 1024	60 fps	29 codes/sec	6 mm	40-120 mm, manual focus	IDMVS	USB3.0	12 - 24 VDC	Approx.4.6 W@5 VDC	White/Red/Blue	Green LED	0 - 50 °C	46 mm × 38 mm × 25 mm	A

Notice: * will be released soon.
x products with different light source

Dimension

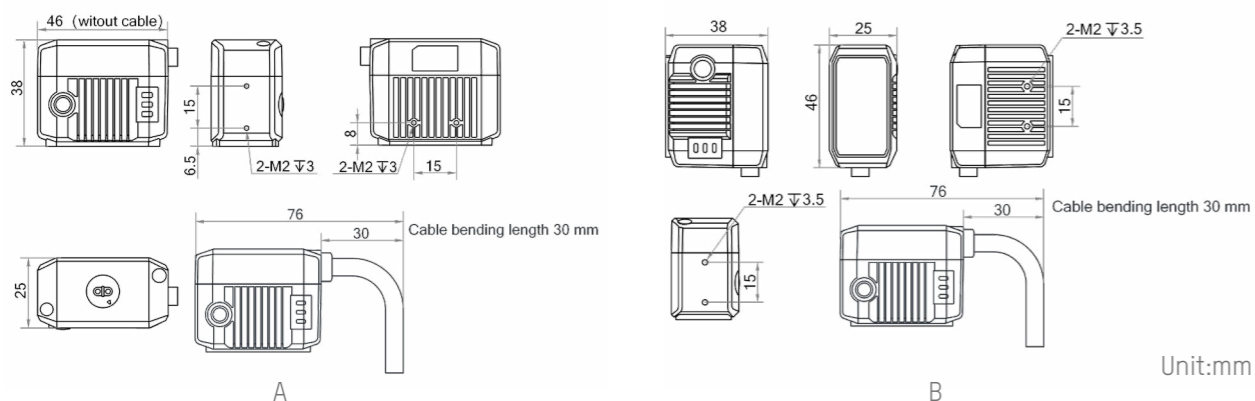

Unit:mm

■ ID3000 Series Smart Code Reader

Key Features

- Adopt CMOS sensor to acquire image data and provide high-quality image.
- Support reading multiple codes, such as Code 39, Code 93, Code 128, CodaBar, EAN, ITF25, QR, DM, etc.
- External focusing knob, providing quick focus method.
- Adopt multiple IO interfaces for input and output signals.
- Adopt OK/NG, PWR, STS and LNK indicators for displaying different statuses.
- Support TCP/IP, Serial, FTP, PROFINET, Ethernet/IP and other transmission protocols.
- Modular light source design, controllable branch and convenient replacement.
- IP67 protection, cope with harsh industrial application environment.



Specifications

Model	Sensor size	Pixel size	Resolution	Frame rate	Reading speed	Focal Length	Client software	Ethernet	Power Supply	Max. power consumption	Working temperature	Lens cap	Light source	Lens mount	Dimension	Label
MV-ID3004PM	1/2.9"	6.9 μm	704×540	60 fps	87 codes/sec	6/12/14.8 mm	IDMVS	Fast Ethernet	24 VDC	Approx.20 W@24 VDC	0 - 50 °C	Transparent, Polarization is optional	White. Red/Blue/NIR is optional	M12	Manual focus: 65.2 mm × 65.2 mm × 42 mm	A
															Mechanical focus: 65.2 mm × 65.2 mm × 42 mm	B
MV-ID3016PM	1/2.9"	3.45 μm	1408×1024	60 fps	84 codes/sec	6/12/14.8 mm	IDMVS	Fast Ethernet	24 VDC	Approx.20 W@24 VDC	0 - 50 °C	Transparent, Polarization is optional	White. Red/Blue/NIR is optional	M12	Manual focus: 65.2 mm×65.2 mm×42 mm	A
															Mechanical focus: 65.2 mm × 65.2 mm × 42 mm	B
MV-ID3050PM*	1/1.7"	3.2 μm	2368×1760	60 fps	60 codes/sec	8/12/16/25 mm	IDMVS	Fast Ethernet	24 VDC	Approx.20 W@24 VDC	0 - 50 °C	Transparent, Polarization is optional	White. Red/Blue/NIR is optional	M12	Mechanical focus: 65.2 mm × 65.2 mm × 47 mm	C

Notice: * will be released soon.

Dimension

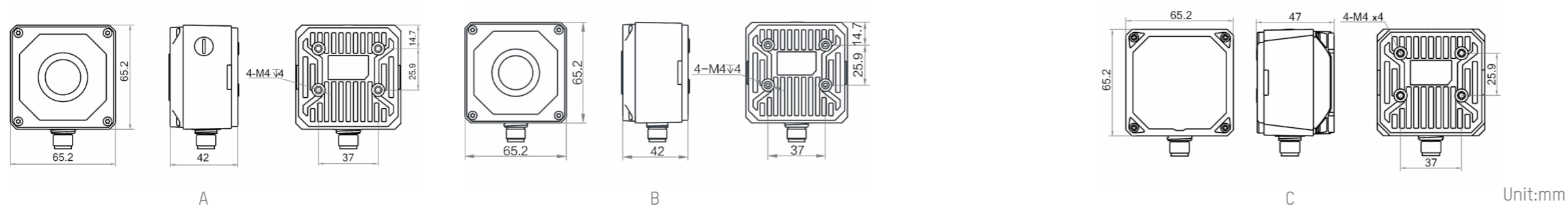

■ ID5000 Series Smart Code Reader

Key Features

- Select 1.6MP-20MP high-performance sensor, high-speed image data acquisition and excellent image quality.
- Built-in deep learning code reading algorithm. Adapt to a variety of complex working conditions with robustness.
- Optional mechanical focus lens, auto-focusing and easy debugging.
- Support digital scoring of coding level.
- Support reading multiple codes, such as Code 39, Code 93, Code 128, CodaBar, EAN, ITF25, QR, DM, etc.
- Multifunctional indicator on the top. Support customization and quickly observe the working status.
- Integrated shunt controllable lighting module provide diverse options.
- IP67 protection, cope with harsh industrial application environment.



Specifications

Model	Sensor size	Pixel size	Resolution	Frame rate	Reading speed	Focal Length	Client software	Ethernet	Power Supply	Max. power consumption	Working temperature	Lens cap	Light source	Lens mount	Dimension	Label
MV-ID5016M-xxS-WBN	1/2.9"	3.45 μm	1408 × 1024	60 fps	90 codes/sec	6/12/15/25 mm	IDMVS	GigE	24 VDC	Approx.36 W@24 VDC	0 - 50 °C	Transparent ,Polarization is optional	White. Red/blue is optional	M12	118.7 mm × 78 mm × 73.2 mm	A
MV-ID5016M-00C-WBN*	1/2.9"	3.45 μm	1408 × 1024	60 fps	90 codes/sec	/	IDMVS	GigE	24 VDC	Approx.36 W@24 VDC	0 - 50 °C	With lens cap	White. Red/blue is optional	C	118.7 mm × 78 mm × 92.7 mm	B
MV-ID5016M-00C-NNN*	1/2.9"	3.45 μm	1408 × 1024	60 fps	90 codes/sec	/	IDMVS	GigE	24 VDC	Approx.36 W@24 VDC	0 - 50 °C	With lens cap	/	C	109.5 mm × 64.4 mm × 109 mm	C
MV-ID5050M-xxS-WBN*	1/1.7"	3.2 μm	2368 × 1760	40 fps	90 codes/sec	8/12/15/25 mm	IDMVS	GigE	24 VDC	Approx.60 W@24 VDC	0 - 50 °C	Semi-polarized, Transparent /Polarization is optional	White, Red/Blue/NIR is optional	M12	112.5 mm × 65.5 mm × 63.3 mm	D
MV-ID5060M-xxS-WBN	1/1.8"	2.4 μm	3072 × 2048	30 fps	90 codes/sec	8/12/15/25 mm	IDMVS	GigE	24 VDC	Approx.20 W@24 VDC	0 - 50 °C	Transparent ,Polarization is optional	White, Red/Blue/NIR is optional	M12	118.7 mm × 78 mm × 73.2 mm	A
MV-ID5060M-00C-WBN	1/1.8"	2.4 μm	3072 × 2048	30 fps	90 codes/sec	/	IDMVS	GigE	24 VDC	Approx.20 W@24 VDC	0 - 50 °C	With lens cap	White, Red/Blue/NIR is optional	C	118.7 mm × 78 mm × 92.7 mm	B
MV-ID5060M-00C-NNN*	1/1.8"	2.4 μm	3072 × 2048	30 fps	90 codes/sec	/	IDMVS	GigE	24 VDC	Approx.20 W@24 VDC	0 - 50 °C	With lens cap	/	C	109.5 mm × 64.4 mm × 109 mm	C
MV-ID5120M-00C-NNN	1"	3.2 μm	4096 × 3072	28 fps	84 codes/sec	/	IDMVS	GigE	12 VDC -24 VDC	Approx.12 W@24 VDC	0 - 50 °C	With lens cap	/	C	109.5 mm × 64.4 mm × 109 mm	C
MV-ID5200M-00C-NNN*	1"	2.4 μm	5440 × 3648	20 fps	36 codes/sec	/	IDMVS	GigE	12 VDC -24 VDC	Approx.12 W@24 VDC	0 - 50 °C	Transparent ,Polarization is optional	/	C	109.5 mm × 64.4 mm × 109 mm	C

Notice: * will be released soon.
xx products with different focal Lengths

Dimension

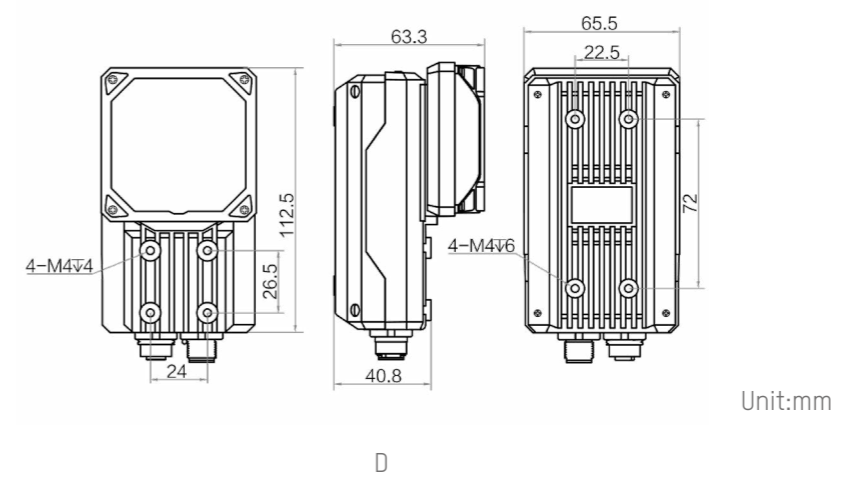
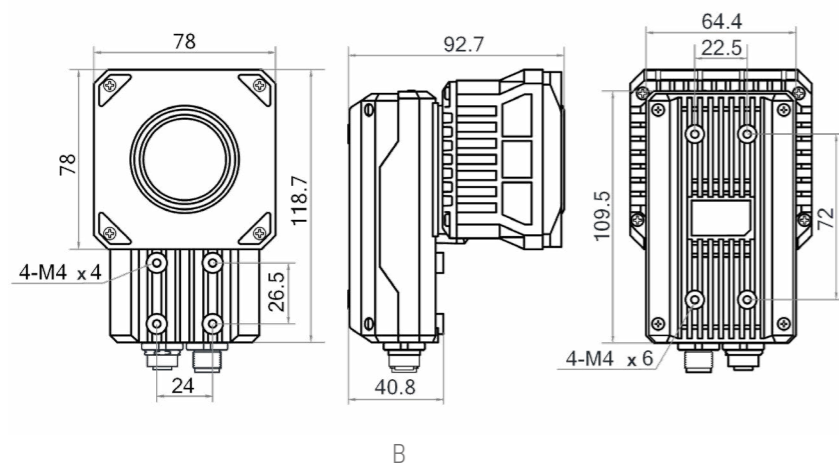
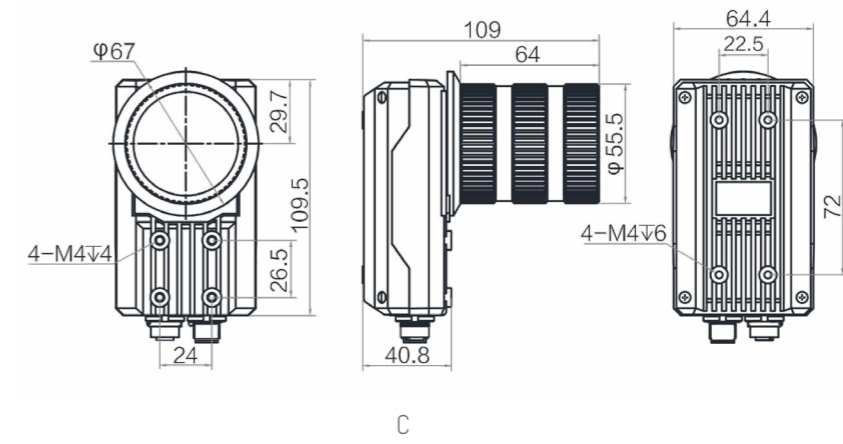
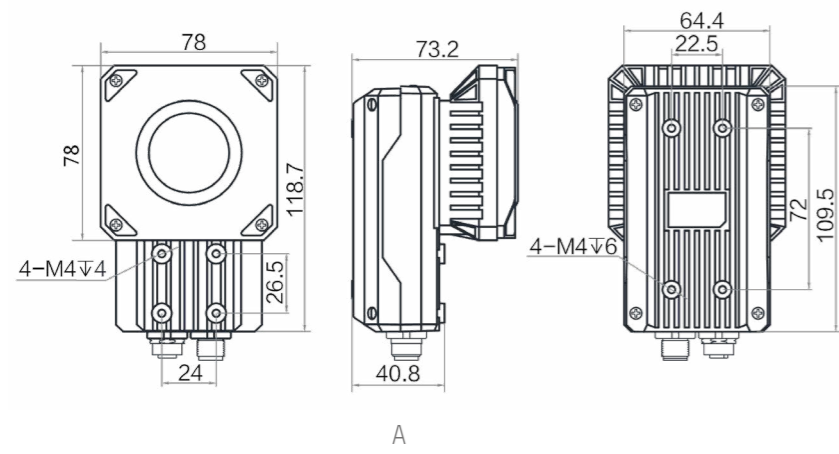

Unit:mm

■ ID6000 Series Smart Code Reader

Key Features

- Provide 20MP and 12MP ultra high resolution, covering a enormous field of view.
- Provide 8.9MP high-resolution global shutter, adapt to high-speed scenes and provide 4K horizontal resolution.
- Provide logistics-specific deep learning barcode reading algorithms to deal with various types of distortion, wrinkles, dirt, and broken barcodes in logistics scenarios.
- Support multiple barcode recognition and waybill cutout.
- Gigabit transmission, support original image output and archive.
- Support networking, construct multi-code reader system through codemaster.
- IP67 protection, cope with harsh industrial application environment.



Specifications

Model	Sensor size	Pixel size	Resolution	Frame rate	Reading speed	Client software	Ethernet	Power Supply	Max. power consumption	Working temperature	Lens cap	Light source	Lens mount	Dimension	Label
MV-ID6089M-00C-NNG	1"	3.45 μm	4096 × 2160	30 fps	90 codes/sec	IDMVS	GigE	12 ~ 24 VDC	Approx.12 W@24 VDC	0 ~ 50 °C	Included	Not included	C	126 mm × 66 mm × 113.2 mm	A
MV-ID6120PM-00C-NNG	1"	3.2 μm	4096 × 3072	28 fps	84 codes/sec	IDMVS	GigE	12 ~ 24 VDC	Approx.12 W@24 VDC	0 ~ 50 °C	Included	Not included	C	126 mm × 66 mm × 113.2 mm	A
MV-ID6200EM-00C-NNG	1"	2.4 μm	5440 × 3648	10 fps	30 codes/sec	IDMVS	GigE	12 ~ 24 VDC	Approx.12 W@24 VDC	0 ~ 50 °C	Not included	Not included	C	126 mm × 66 mm × 55.3 mm	B
MV-ID6200M-00C-NNG	1"	2.4 μm	5440 × 3648	20 fps	60 codes/sec	IDMVS	GigE	12 ~ 24 VDC	Approx.12 W@24 VDC	0 ~ 50 °C	Included	Not included	C	126 mm × 66 mm × 113.2 mm	A

Dimension

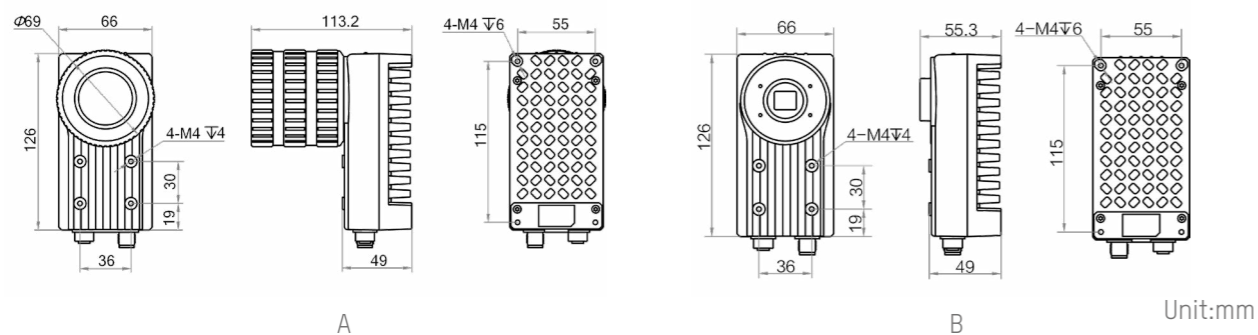

■ IDH Series Handheld Smart Code Reader

Key Features

- Using self-developed high-performance barcode recognition algorithm, it can efficiently read barcodes of mainstream symbologies.
- The algorithm is robust and can effectively cope with the situation of dirty, defective, low-contrast barcodes, etc.
- Support continuous code reading and batch reading mode, greatly improving the reading efficiency of multi-code scenes.
- Support reading multiple codes, such as Code 39, Code 93, Code 128, CodaBar, EAN, ITF25, QR, DM, etc.
- Support TCP/IP, Serial, FTP, Profinet, Ethernet/IP, MELSEC, Fins and other transmission protocols.
- Multi-light source lighting system, which can intelligently switch between red and white light sources.
- IP67 protection and 1.8 meters drop height, cope with harsh industrial application environment.



Specifications

Model	Sensor size	Pixel size	Resolution	Frame rate	Min. accuracy	Focal length	Focus position	Aiming	Client software	Ethernet	Power Supply	Max. power consumption	Working temperature	Dimension
MV-IDH5010-05-NR-L*	1/4"	3 μm × 3 μm	1280 × 800	50 fps	3 mil	5 mm	70 mm	Cross laser	IDMVS	Fast Ethernet,RS-232	12-24 VDC	4.94 W@12 VDC	-20-50 °C	169.4 mm × 73.8 mm × 104.6 mm
MV-IDH5010-05-NR-U*	1/4"	3 μm × 3 μm	1280 × 800	50 fps	3 mil	5 mm	70 mm	Cross laser	IDMVS	USB3.0	5 VDC	4.36 W@5 VDC	-20-50 °C	169.4 mm × 73.8 mm × 104.6 mm
MV-IDH5010-05-SR-L*	1/4"	3 μm × 3 μm	1280 × 800	50 fps	3 mil	5 mm	120 mm	Cross laser	IDMVS	Fast Ethernet,RS-232	12-24 VDC	4.94 W@12 VDC	-20-50 °C	169.4 mm × 73.8 mm × 104.6 mm
MV-IDH5010-05-SR-U*	1/4"	3 μm × 3 μm	1280 × 800	50 fps	3 mil	5 mm	120 mm	Cross laser	IDMVS	USB3.0	5 VDC	4.36 W@5 VDC	-20-50 °C	169.4 mm × 73.8 mm × 104.6 mm

Notice: * will be released soon.

Dimension

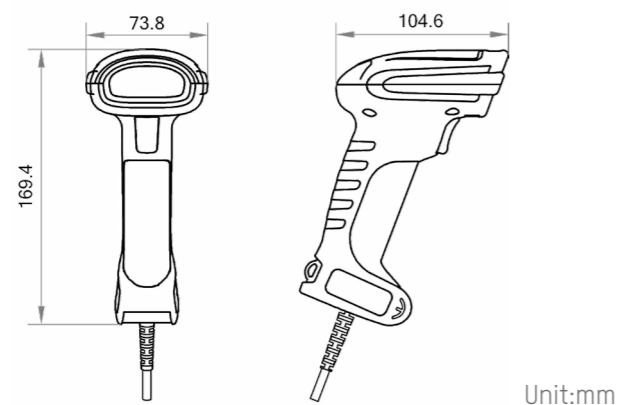

■ PD Series Smart Code Reader

Key Features

- Integrated structure design of camera lens light source, high integration, ready to use out of the box, convenient installation and debugging.
- Built-in deep learning code reading algorithm, efficiently read a variety of logistics bar codes.
- Realize the collection and integration of images and data, local storage and upload, and provide traceability basis.
- Adopt professional light path design, high energy utilization rate, stable performance of lamp beads and long lifespan.
- Adjustable light source brightness, strong environmental adaptability.
- Seamlessly connect with common express logistics management systems to provide real-time and effective data for logistics and production enterprises.



Specifications

Model	Resolution	Focal Length	Best working distance	Field of view(@10 mil)	Depth of field	Uniformity	Luminous flux	Color temperature	Data interface	Power Supply	Max. power consumption	Working temperature	Dimension	Label
MV-PD010003-21	3072 × 2048	12 mm	900 mm	550 mm × 340 mm	550 mm	0.53	2500 lm	5700 K	GigE	24 VDC	40 W@24 VDC	0-50 °C	153.4 mm × 164.4 mm × 159.1 mm	A
MV-PD010003-23	4024 × 3036	16 mm	1550 mm	730 mm × 550 mm	650 mm	0.56	5900 lm	6500 K	GigE	24 VDC	60 W@24 VDC	0-50 °C	153.4 mm × 164.4 mm × 159.1 mm	B

Dimension

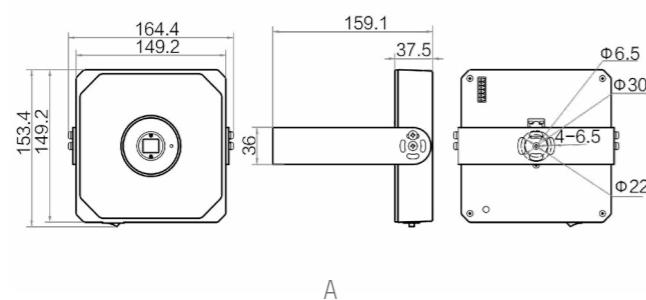

A

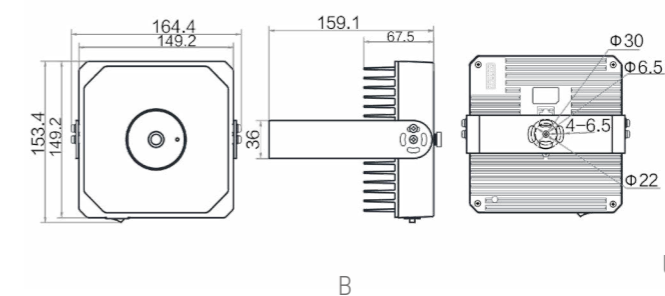

B

Unit:mm

3D Camera

Line Laser 3D Camera



Key Features

- Built-in HDR algorithm.
- Sub-pixel algorithm technology, accuracy up to 5mm.
- High power laser module, wider dynamic range.
- Narrow band filter, stronger anti-interference ability.
- Support RAW data, point cloud data or volume result output.
- KC, CE, FCC, RoHs certification.



Specifications

Model	Near FOV	Far FOV	Clearance distance (CD)	Measurement range (MR)	Accuracy	Inspection speed	Scan rate	Data format	Sync signal mode	Data interface	Laser class	Power consumption	Working temperature	Dimension	Label
MV-DL1617-05L	1000 mm	2235 mm	750 mm	1000 mm	±5 mm	1.5 m/s@±5 mm Accuracy	200 Hz@1 m³ MR	Point cloud data	External trigger, Encoder input trigger	GigE	3B	Approx.11 W@12 VDC	0~45°C	549.4 mm × 65 mm × 160 mm	A
MV-DL1617-05L (metrological certification package)	1000 mm	2235 mm	750 mm	1000 mm	±5 mm	3 m/s@±5 mm Accuracy	600 Hz@1 m³ MR	Point cloud data	External trigger, Encoder input trigger	GigE	3B	Approx.10 W@12 VDC	0~45°C	549.4 mm × 65 mm × 160 mm	A
MV-DL2025-04H-H*	1000 mm	2600 mm	650 mm	1000 mm	±5 mm	3 m/s@±5 mm Accuracy	600 Hz@1 m³ MR	Point cloud data, length, width and height dimensions, integral volume, top surface coordinates	External trigger, Encoder input trigger	GigE	3B	Approx.10 W@12 VDC	0~45°C	354.1 mm × 65 mm × 123.4 mm	B

Notice: * will be released soon.

Dimension

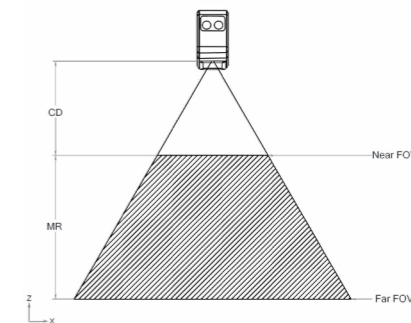
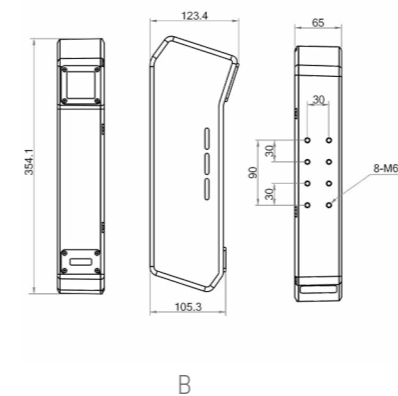
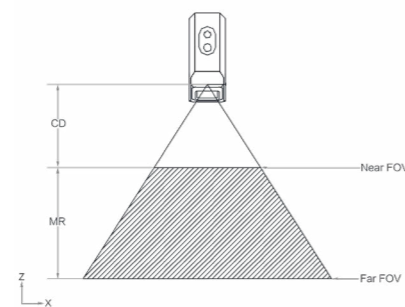
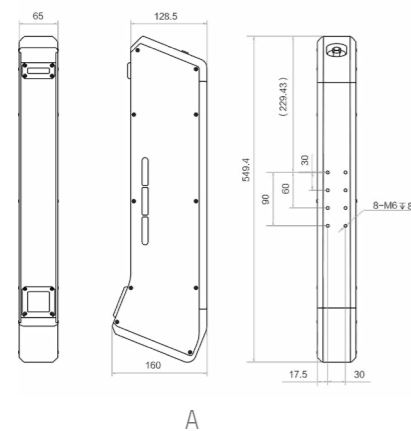

Unit:mm

■ Binocular 3D Camera

Key Features

- Built-in volume measure algorithm.
- High power laser module, wider dynamic range.
- Narrow band filter, stronger anti-interference ability.
- Support depth image or volume result output.
- KC, CE, FCC, RoHs certification.



Specifications

Model	Near FOV	Far FOV	Clearance distance (CD)	Measurement range (MR)	Accuracy	Scan rate	Data format	Data interface	Laser class	Power consumption	Working temperature	Dimension
MV-DB1612-05H	1100 mm x 950 mm	2050 mm x 1750 mm	1000 mm	800 mm	±8 mm	9 fps@depth image 4 fps@volume result	Depth image or Volume result	GigE	3R	Approx.8 W@12 VDC	0~45°C	181.6 mm × 55.2 mm × 46 mm

Dimension

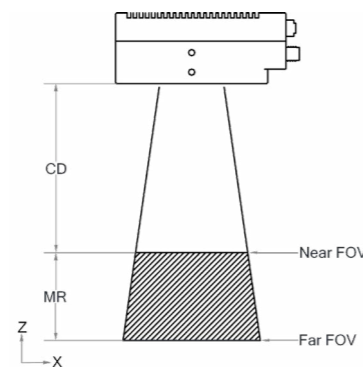
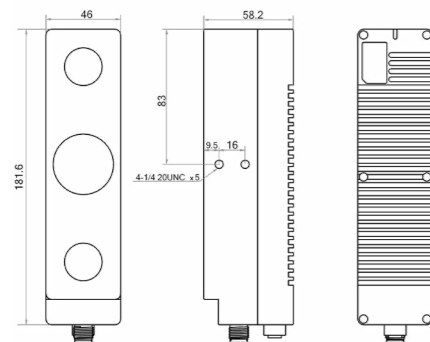

Unit:mm

Vision Box

■ VB2000 Series Vision Controller



Key Features

- On-board Intel® E3845 SoC, 1.91GHz CPU.
- 4GB DDR3L memory and onboard SSD of high reliability.
- 3 Intel GigE ports and enhanced anti-surge design to ensure the stable running of the machine vision cameras.
- Supports multiple opto-isolated inputs and outputs.
- Controls the light via light interface.
- Adopts 2 HDMI interfaces and supports independent display.
- KC, CE, FCC, RoHS certification.



Specifications

Model	CPU	Memory	Storage	Graphics	OS	HDMI	Digital I/O	Light Interface	GigE	USB3.0	USB2.0(+built-in)	RS485	RS232	Power supply	Power consumption	Working temperature	Dimension
MV-VB2210-120G	Intel® E3845 SoC, 1.91GHz CPU	4GB	128GB SSD	Integrated Gen7 GPU Support hardware-accelerated 3D imaging Support hardware-accelerated decoding of multiple video formats	Windows 7/10	2	Opto-isolated input × 4, opto-isolated output × 4	1	3	1	3+1	1	1	24 VDC/2.5 A	34W	0-50°C	134.8 mm × 91 mm × 45 mm
MV-VB2220-120G	Intel® E3845 SoC, 1.91GHz CPU	4GB	128GB SSD	Integrated Gen7 GPU Support hardware-accelerated 3D imaging Support hardware-accelerated decoding of multiple video formats	Windows 7/10	2	Opto-isolated input × 4, opto-isolated output × 4	1	3	1	3+1	1	1	24 VDC/2.5 A	26W	0-50°C	134.8 mm × 91 mm × 45 mm

Dimension

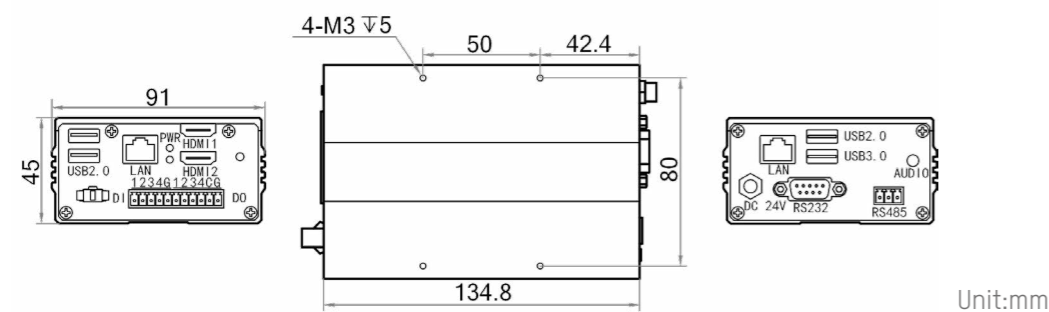

VC3000 Series Vision Controller



Key Features

- Intel SkyLAKE platform CPU powering the processing performance.
- Rich expansion slots for frame grabber interface expansion with strong stability.
- Provide 12 I/O interfaces.
- Adopt Intel GigE network card, ensuring fast and stable data transmission; POE is available for option.
- Built-in dual USB3.0 dongle interfaces, to ease the setup and maintenance on site.
- Serial port expansion module, light source expansion module and IO expansion module can be installed as needed.



Specifications

Model	CPU	Memory	Storage	GPU	OS	HDMI	VGA	Digital I/O	GigE	USB3.0	USB2.0	Serial port	Extended interface	Power supply	Power consumption	Working temperature	Dimension
MV-VC3101-128G60	Intel® G4900T, 2.9 GHz	8GB	128G SSD	Intel® HD Graphics 610	Windows 10	1	1	Opto-isolated input × 3, opto-isolated output × 8 Output supports NPN/PNP switch	6	4	4	RS-232×2, can be configured as RS-485 and RS-422	No	24 VDC	Approx. 60 W	0~48 °C	161.4 mm × 208.5 mm × 105.5 mm
MV-VC3102-128G60	Intel® G4900T, 2.9 GHz	8GB	128G SSD + 2T HDD	Intel® HD Graphics 610	Windows 10	1	1	Opto-isolated input × 3, opto-isolated output × 8 Output supports NPN/PNP switch	6	4	4	RS-232×2, can be configured as RS-485 and RS-422	PCIe x16 X1/ mSATA X1	24 VDC	Approx. 60 W	0~48 °C	161.4 mm × 208.5 mm × 105.5 mm
MV-VC3201-128G60	Intel® G5400T, 3.1 GHz	8GB	128G SSD	Intel® HD Graphics 610	Windows 10	1	1	Opto-isolated input × 3, opto-isolated output × 8 Output supports NPN/PNP switch	6	4	4	RS-232×2, can be configured as RS-485 and RS-422	No	24 VDC	Approx. 60 W	0~48 °C	161.4 mm × 208.5 mm × 105.5 mm
MV-VC3202-128G60	Intel® G5400T, 3.1 GHz	8GB	128G SSD + 2T HDD	Intel® HD Graphics 610	Windows 10	1	1	Opto-isolated input × 3, opto-isolated output × 8 Output supports NPN/PNP switch	6	4	4	RS-232×2, can be configured as RS-485 and RS-422	PCIe x16 X1/ mSATA X1	24 VDC	Approx. 60 W	0~48 °C	161.4 mm × 208.5 mm × 105.5 mm
MV-VC3301-128G60	Intel® i3-8100T	8GB	128G SSD	Intel® HD Graphics 630	Windows 10	1	1	Opto-isolated input × 3, opto-isolated output × 8 Output supports NPN/PNP switch	6	4	4	RS-232×2, can be configured as RS-485 and RS-422	No	24 VDC	Approx. 60 W	0~42 °C	161.4 mm × 208.5 mm × 105.5 mm
MV-VC3302-128G60	Intel® i3-8100T	8GB	128G SSD + 2T HDD	Intel® HD Graphics 630	Windows 10	1	1	Opto-isolated input × 3, opto-isolated output × 8 Output supports NPN/PNP switch	6	4	4	RS-232×2, can be configured as RS-485 and RS-422	PCIe x16 X1/ mSATA X1	24 VDC	Approx. 60 W	0~42 °C	161.4 mm × 208.5 mm × 105.5 mm
MV-VC3303-128G60	Intel® i3-8100T	8GB	128G SSD + 2T HDD	Intel® HD Graphics 630	Windows 10	1	1	Opto-isolated input × 3, opto-isolated output × 8 Output supports NPN/PNP switch	2+4poe	4	4	RS-232×2, can be configured as RS-485 and RS-422	PCIe x16 X1/ mSATA X1	24 VDC	Approx. 60 W	0~42 °C	161.4 mm × 208.5 mm × 105.5 mm
MV-VC3501-128G60	Intel® i5-8500T, 2.1 GHz, max. 3.5 GHz	8GB	128 GB SSD	Intel® HD Graphics 630	Windows 10	1	1	Opto-isolated input × 3, opto-isolated output × 8 Output supports NPN/PNP switch	6	4	4	RS-232×2, can be configured as RS-485 and RS-422	No	24 VDC	Approx. 60 W	0~60 °C	161.4 mm × 208.5 mm × 105.5 mm

Model	CPU	Memory	Storage	GPU	OS	HDMI	VGA	Digital I/O	GigE	USB3.0	USB2.0	Serial port	Extended interface	Power supply	Power consumption	Working temperature	Dimension
MV-VC3502-128G60	Intel® i5-8500T, 2.1 GHz, max. 3.5 GHz	8GB	128 GB SSD + 2T HDD	Intel® HD Graphics 630	Windows 10	1	1	Opto-isolated input × 3, opto-isolated output × 8 Output supports NPN/PNP switch	6	4	4	RS-232×2, can be configured as RS-485 and RS-422	PCIe x16 X1/ mSATA X1	24 VDC	Approx. 60 W	0-60 °C	161.4 mm × 208.5 mm × 105.5 mm
MV-VC3503-128G60	Intel® i5-8500T, 2.1 GHz, max. 3.5 GHz	8GB	128 GB SSD + 2T HDD	Intel® HD Graphics 630	Windows 10	1	1	Opto-isolated input × 3, opto-isolated output × 8 Output supports NPN/PNP switch	2+4poe	4	4	RS-232×2, can be configured as RS-485 and RS-422	PCIe x16 X1/ mSATA X1	24 VDC	Approx. 60 W	0-60 °C	161.4 mm × 208.5 mm × 105.5 mm

Dimension

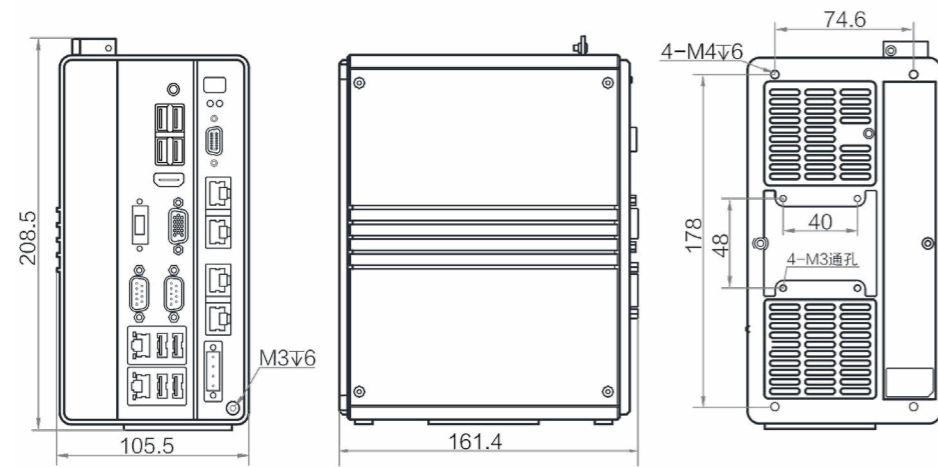

Unit:mm

Lens

HF-E Series (1/1.8" 6MP)



Key Features

- Higher image clarity and contrast ratio.
- Ultra-low distortion and higher relative illumination rate.
- Good optical performance at ultra-short working distance.
- Compact design, convenient for device integration.



Specifications

Model	Focal Length (mm)	F No.	Distortion	Field of View			M.O.D (m)	Filter Thread	Mount	Operating Temperature	Dimension	Label
				D	H	V						
MVL-HF0628M-6MPE	6	F2.8-F16	-0.10%	73.49°	63.11°	44.59°	0.1	M37.5 × 0.5	C-Mount	-10-50 °C	Φ39 × 32.53 mm	A
MVL-HF0828M-6MPE	8	F2.8-F16	0.05%	58.50°	49.46°	34.19°	0.1	M30.5 × 0.5	C-Mount	-10-50 °C	Φ33 × 34.47 mm	B
MVL-HF1228M-6MPE	12	F2.8-F16	-0.01%	40.94°	34.14°	23.17°	0.1	M27 × 0.5	C-Mount	-10-50 °C	Φ33 × 40.23 mm	C
MVL-HF1628M-6MPE	16	F2.8-F16	-0.02%	31.28°	25.94°	17.48°	0.1	M27 × 0.5	C-Mount	-10-50 °C	Φ33 × 31.87 mm	D
MVL-HF2528M-6MPE	25	F2.8-F16	-0.03%	20.32°	16.77°	11.24°	0.2	M27 × 0.5	C-Mount	-10-50 °C	Φ33 × 30.22 mm	E
MVL-HF3028M-6MPE	30	F2.8-F16	-0.03%	16.99°	14.01°	9.38°	0.2	M27 × 0.5	C-Mount	-10-50 °C	Φ33 × 29.37 mm	F
MVL-HF4028M-6MPE	40	F2.8-F16	-0.02%	12.78°	10.53°	7.04°	0.25	M27 × 0.5	C-Mount	-10-50 °C	Φ33 × 41.47 mm	G
MVL-HF5028M-6MPE	50	F2.8-F16	0.30%	9.72°	7.84°	5.24°	0.25	M30.5 × 0.5	C-Mount	-10-50 °C	Φ37 × 51.69 mm	H

Dimension

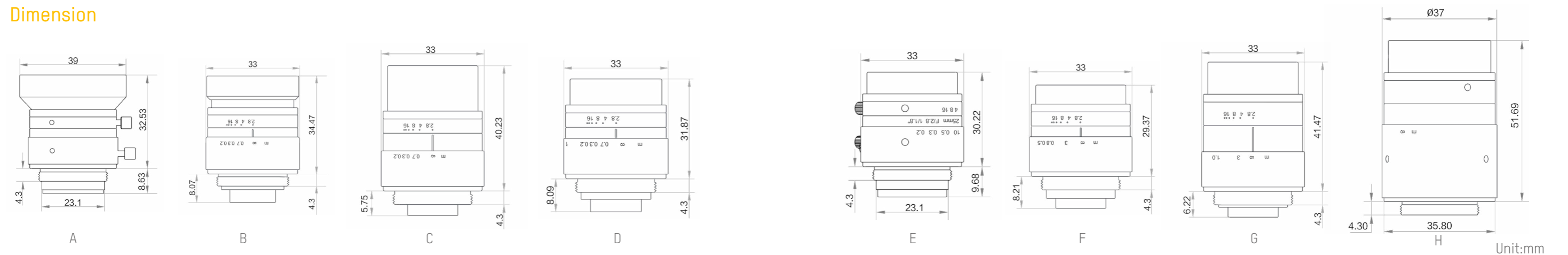

HF-P Series (1/1.8" 10MP)

Key Features

- Ultra-high resolution and consistency of image clarity.
- Bigger aperture, lower distortion and higher relative illumination rate.
- Achromatic optical system design, better imaging performance with color camera.
- Excellent vibration resistance performance, optical axis shifting within pixel level.
- Good stability at high and low temperature.
- Multilayer and broadband coating design, compatible with visible and near-infrared applications.



Specifications

Model	Focal Length (mm)	F No.	Distortion	Field of View			M.O.D (m)	Filter Thread	Mount	Operating Temperature	Dimension	Label
				D	H	V						
MVL-HF0624M-10MP	6	F2.4-F16	0.37%	72.96°	62.46°	44.05°	0.1	-	C-Mount	-10-50 °C	Φ29.8 × 40.9 mm	A
MVL-HF0824M-10MP	8	F2.4-F16	-0.67%	58.81°	49.56°	34.04°	0.1	M27 × 0.5	C-Mount	-10-50 °C	Φ29 × 34.8 mm	B
MVL-HF1224M-10MP	12	F2.4-F16	0.15%	40.2°	33.6°	22.9°	0.1	M27 × 0.5	C-Mount	-10-50 °C	Φ29 × 37 mm	C
MVL-HF1624M-10MP	16	F2.4-F16	-0.02%	30.17°	25.07°	16.92°	0.1	M27 × 0.5	C-Mount	-10-50 °C	Φ29 × 38.36 mm	D
MVL-HF2524M-10MP	25	F2.4-F16	-0.01%	19.67°	16.19°	10.85°	0.1	M27 × 0.5	C-Mount	-10-50 °C	Φ29 × 41.43 mm	E
MVL-HF3524M-10MP	35	F2.4-F16	0.01%	13.47°	11.03°	7.34°	0.15	M27 × 0.5	C-Mount	-10-50 °C	Φ29 × 51.68 mm	F
MVL-HF5024M-10MP	50	F2.4-F16	0.03%	9.10°	7.48°	5.00°	0.3	M27 × 0.5	C-Mount	-10-50 °C	Φ29.5 × 52 mm	G

Dimension

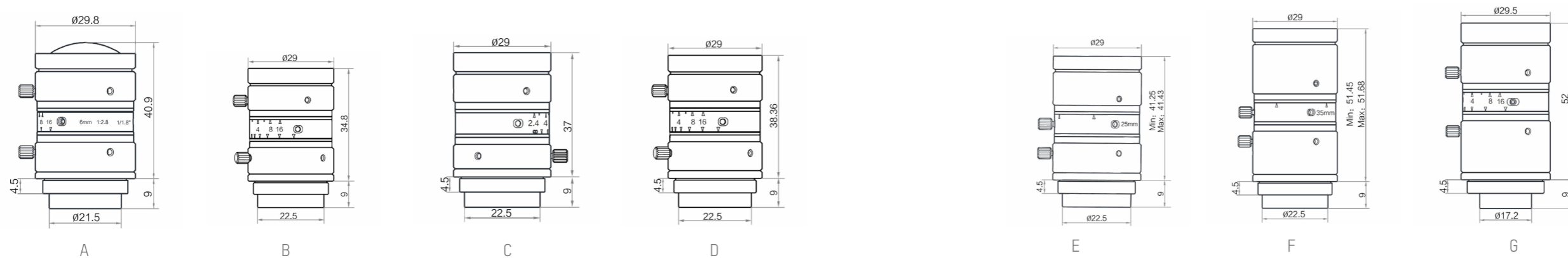

Unit:mm

MF Series (2/3" 8MP)

Key Features

- Ultra-high resolution and consistency of image clarity.
- Lower distortion and higher relative illumination rate.
- Achromatic optical system design, better imaging performance with color camera.
- Good stability at high and low temperature and excellent vibration resistance performance.
- Supports ultra-short working distance with good optical performance.



Specifications

Model	Focal Length (mm)	F No.	Distortion	Field of View			M.O.D (m)	Filter Thread	Mount	Operating Temperature	Dimension	Label
				D	H	V						
MVL-MF0828M-8MP	8	F2.8-F16	0.28%	68.46	54.97	47.06	0.1	~	C-Mount	-10~50 °C	Φ35 × 40.27 mm	A
MVL-MF1228M-8MP	12	F2.8-F16	0.28%	48.6	37.9	32.04	0.1	M30.5 × 0.5	C-Mount	-10~50 °C	Φ32 × 39.4 mm	B
MVL-MF1628M-8MP	16	F2.8-F16	0.33%	37.39	28.9	24.33	0.1	M27 × 0.5	C-Mount	-10~50 °C	Φ28.5 × 39.33 mm	C
MVL-MF2528M-8MP	25	F2.8-F16	0.01%	23.23	17.78	14.91	0.1	M27 × 0.5	C-Mount	-10~50 °C	Φ30 × 38.59 mm	D
MVL-MF3528M-8MP	35	F2.8-F16	0.02%	15.26	11.65	9.76	0.15	M30.5 × 0.5	C-Mount	-10~50 °C	Φ32 × 48.43 mm	E
MVL-MF5028M-8MP	50	F2.8-F16	0.01%	11.67	8.81	7.38	0.4	M27 × 0.5	C-Mount	-10~50 °C	Φ29 × 53.81 mm	F

Dimension

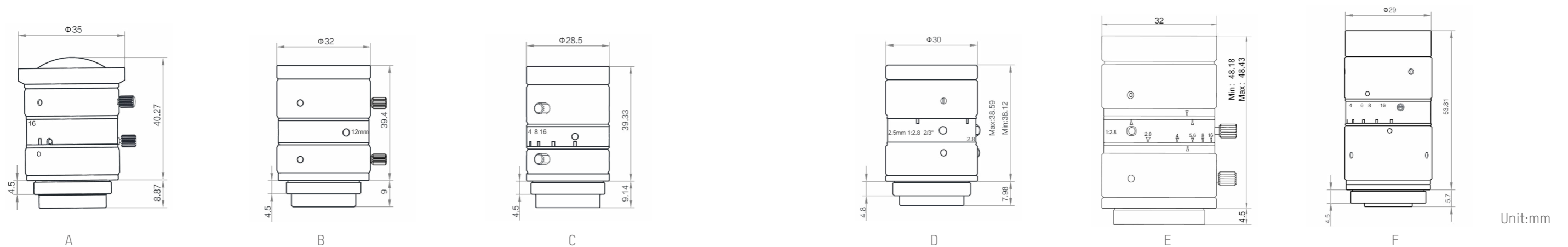

KF-P Series (1.2" 25MP)

Key Features

- Ultra-high resolution and consistency of image clarity.
- Low distortion, high illumination relative.
- Multilayer wide band coating, ensuring high transmittance of visible and near infrared light.
- Support ultra short working distance, maintaining excellent optical properties at different object distances.



Specifications

Model	Focal Length (mm)	F No.	Distortion	Field of View			M.O.D (m)	Filter Thread	Mount	Operating Temperature	Dimension	Label
				D	H	V						
MVL-KF1224M-25MP	12	F2.4-F16	0.39%	76.12°	62.33°	55.33°	0.1	M67 x 0.75	C-Mount	-10-50 °C	Φ50 × 66.96 mm	A
MVL-KF1624M-25MP	16	F2.4-F16	0.07%	61.36°	48.83°	42.86°	0.1	M40.5 x 0.5	C-Mount	-10-50 °C	Φ42.5 × 59.8 mm	B
MVL-KF2524M-25MP	25	F2.4-F16	-0.04%	41.19°	31.42°	27.32°	0.15	M37 x 0.5	C-Mount	-10-50 °C	Φ40 × 58.4 mm	C
MVL-KF3524M-25MP	35	F2.4-F16	0.02%	29.33°	22.51°	19.53°	0.15	M40.5 x 0.5	C-Mount	-10-50 °C	Φ42 × 59.3 mm	D
MVL-KF5024M-25MP	50	F2.4-F16	0.01%	20.5°	15.66°	13.57°	0.25	M40.5 x 0.5	C-Mount	-10-50 °C	Φ42 × 61.2 mm	E

Dimension

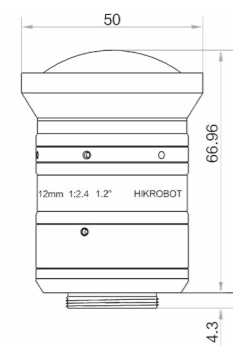

A

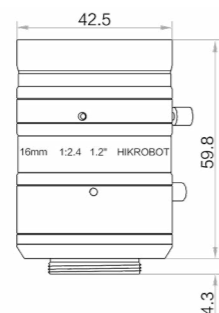

B

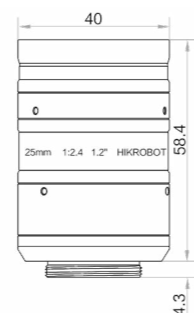

C

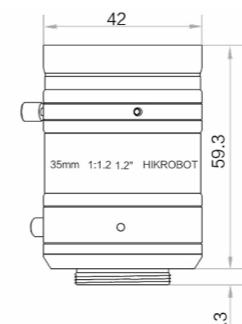

D

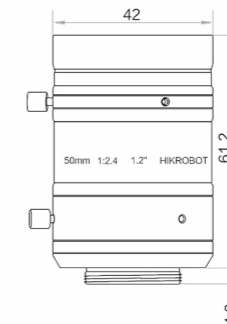

E

Unit:mm

LF Series (Large Image Circle Lens)

Key Features

- Higher resolution, compatible with 3.1 μm pixel size.
- Ultra-high resolution and consistency of image clarity.
- Ultra-low distortion and high relative illumination.
- Optimized optical design for different magnification.
- Optimization for machine vision light sources and sensor.



Specifications

Model	Focal length (mm)	F No.	Optical distortion	Field of View			M.O.D (m)	Recommended Magnification	Filter thread	Mount	Working temperature	Dimension	Label
				D	H	V							
MVL-LF3528M-F	35	F2.8-F16	0.40%	41.96°	35.44°	24.05°	0.13	0.01x-0.16x	M58 × 0.75	F-Mount	-10-50 °C	Φ61 × 81.5 mm	A
MVL-LF5040M-F	50	F4.0-F32	-0.22%	47.02°	39.77°	27.11°	0.15	0.01x-0.33x	M52 × 0.75	F-Mount, extensible to V interface	-10-50 °C	Φ59 × 97.19 mm	B
MVL-LF8040M-F	80	F4.0-F32	0.04%	30.41°	25.47°	17.13°	0.23	0.01x-0.4x	M52 × 0.75	F-Mount, extensible to V interface	-10-50 °C	Φ63 × 120.37 mm	C

Dimension

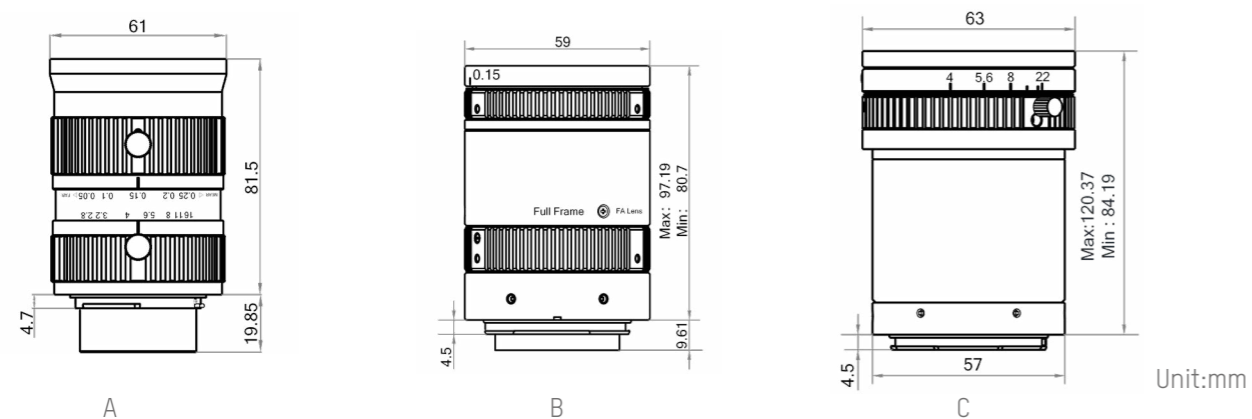

Telecentric Lens

Key Features

- Object telecentric design.
- High resolution, contrast and illumination relative.
- Ultra-low distortion, more suitable for high precision measurement and positioning.
- Standard C-Mount.



Specifications

Model	Amplification Factor	Working Distance (mm)	Image Format	DoF(mm)	Resolution (um)	TV-Distortion	Telecentricity	Aperture	Total Length (mm)	Maximum Diameter(mm)	Optional Coaxial Light Interface	Dimension
MVL-MY-05-110-MP	0.5	110	2/3"	2.98	12	≤0.05%	≤0.1°	9.3	120.5	35	√	Φ35 × 120.5 mm
MVL-MY-07-145-MP	0.7	145	2/3"	3.2	14.3	≤0.1%	≤0.2°	11.2	110.4	28		Φ28 × 110.4 mm
MVL-MY-08-130-MP	0.8	130	2/3"	1.4	9.4	≤0.1%	≤0.1°	11.2	117.1	28	√	Φ28 × 117.1 mm
MVL-MY-1-110-MP	1	110	2/3"	0.88	7.4	≤0.05%	≤0.1°	11	128.4	30	√	Φ30 × 128.45 mm
MVL-MY-2-110-MP	2	110	2/3"	0.27	4.5	≤0.05%	≤0.1°	13.6	130.4	30	√	Φ30 × 130.48 mm
MVL-MY-4-110-MP	4	110	2/3"	0.11	3.7	≤0.05%	≤0.1°	22	110.2	30		Φ30 × 110.24 mm

Dimension

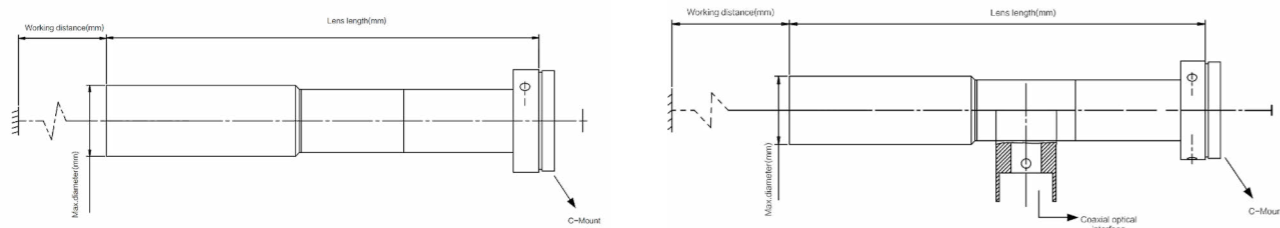

Unit:mm

Machine Vision SDK

Overview

Hikrobot industrial camera SDK is based on GenCam standard, compliant with GigE Vision, USB3 Vision, Camera Link and CoaXPress standard, and can be used to control the connected industrial area cameras and line cameras, supporting camera imaging debugging and secondary development.

Key Features

- High-performance GEV and U3V drivers improve image data transmission and processing capabilities.
- Provide GenTL standard library to access industrial cameras, such as CoaXPress cameras, greatly reducing the development workload.
- Rich API interfaces can be used to facilitate quick and effective secondary development.
- Integrate multiple ISP algorithms to help users obtain the most suitable image through image preprocessing.
- Support implement in Halcon, Labview, Sherlock and other software and can provide DirectShow developing kit.
- Various sample programs, source code, and development documentation are provided for quick start.
- Support further API encapsulation, plug-in, and other forms of customization.

Supported Platforms	Supported Programming Languages
Windows XP/7/10 32/64bits	C
X86/ARM Linux 32/64bits	C++
MacOS 64bits	C#
Android System	VB.NET
	PYTHON
	Delphi
	JAVA

MVS

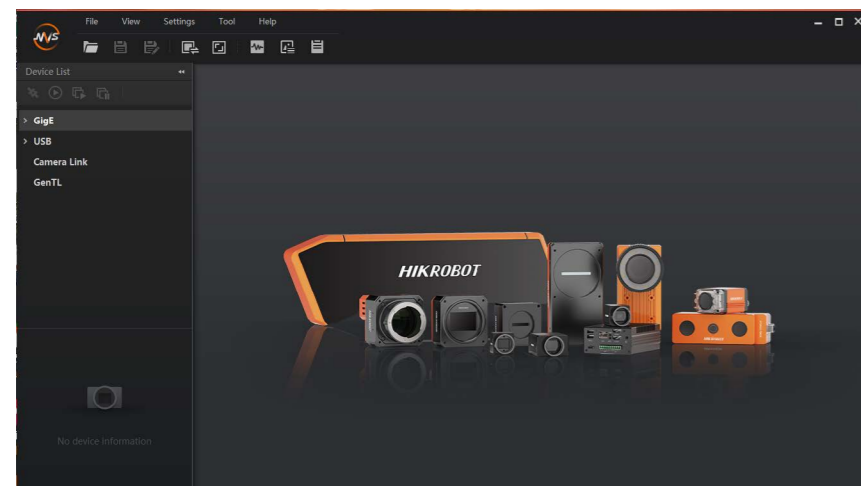

Download



SDK can be downloaded freely by the official website
<https://www.hikrobotics.com/en/machinevision/service/download?module=0>

(Note: the QR code is a link to the download page of Hikrobot official website.)

VM Algorithm Development Platform

Developed by HIKROBOT, VM algorithm development platform is a machine vision software, dedicated to providing users with algorithm tools which help to construct fast visual solutions. It can achieve machine vision applications such as visual locating, size measurement, defect detection, information recognition and etc.

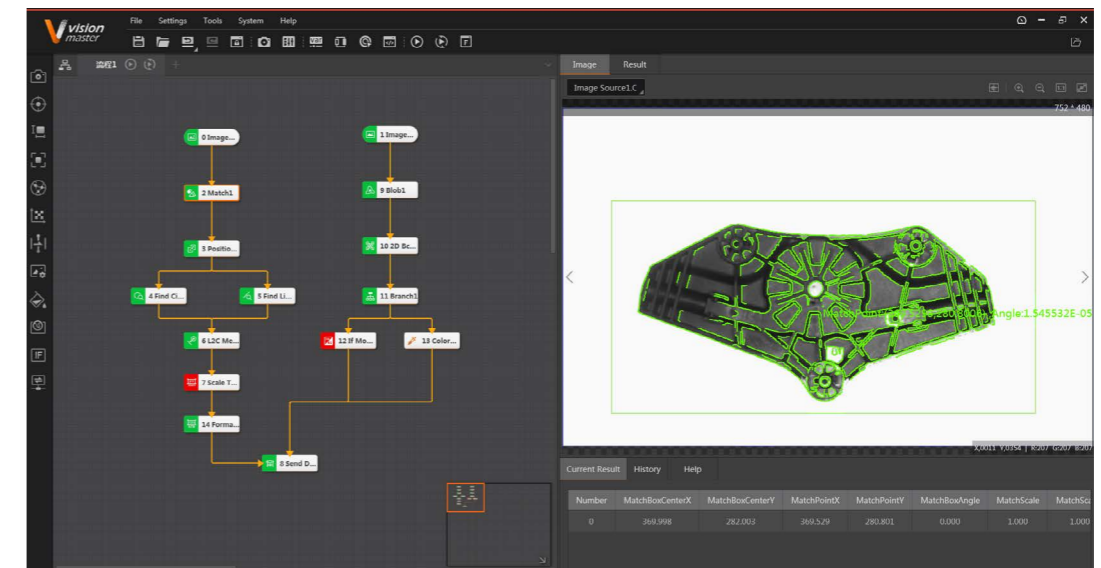

Features

- Composed of over a thousand completely independently developed image processing operators and a variety of interactive development tools, it supports multiple operating systems and image acquisition hardware devices, which can meet the needs of locating, measurement, identification, and detection in the field of machine vision applications.
- Fully graphical interactive interface, intuitive and easy-to-understand function icons, visual solutions can be quickly built with drag-and-drop operation.
- Visual applications can be created according to users' requirements, individual needs from users can be easily achieved by customized operation interface or integrating background images and company logos on it.
- Compatible with GigE Vision and USB3 Vision standards, and cameras of various brands can be connected into the software. Both local image and camera online image processing are supported.

Locating and Measurement Tools

Can accurately and efficiently locate any geometric element in the image, up to 1/16 pixel accuracy.

- Differences caused by sample translation, rotation, zoom and illumination can be overcome with efficient template matching tool.
- Quickly and accurately locating geometries such as circle, line, blob, edge, peak and etc.
- Accurate measurement of shape, size, area, distance, intersection and other geometric characteristics.
- Provide location and presence/absence information for robot guidance and other vision tools.

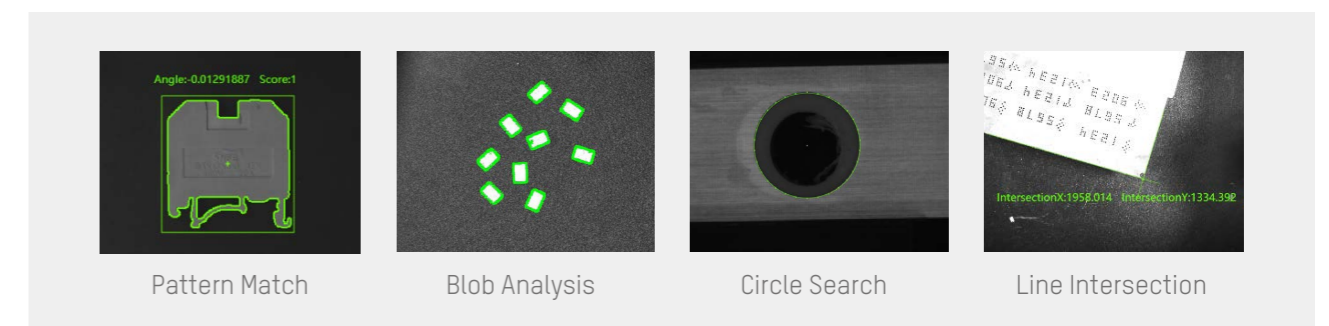

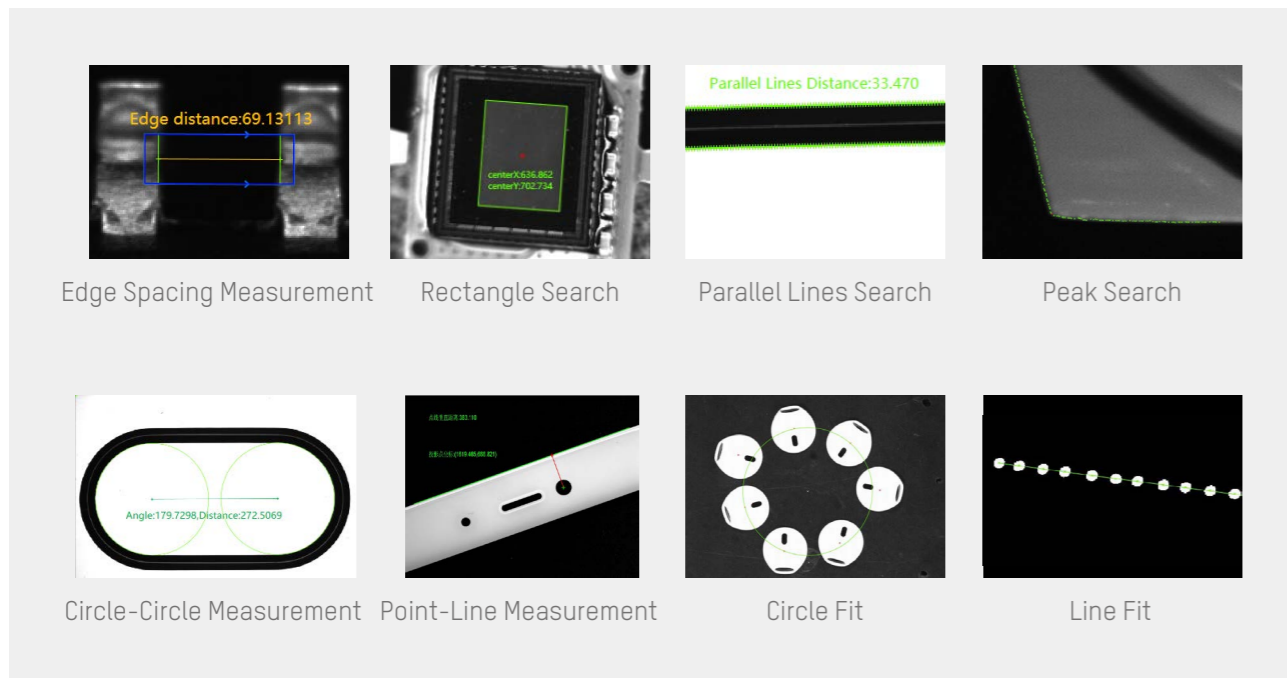

Recognition Tools

- Fast and accurate recognition of digital information codes.
- Well recognition of 1D and 2D codes of multiple formats, different positions, angles, and illumination, regardless the impact of image distortion.
- Provide continuous, accurate, real-time ID information for component tracking.
- Support recognition of multiple VeriCode formats, regardless of strong interference.

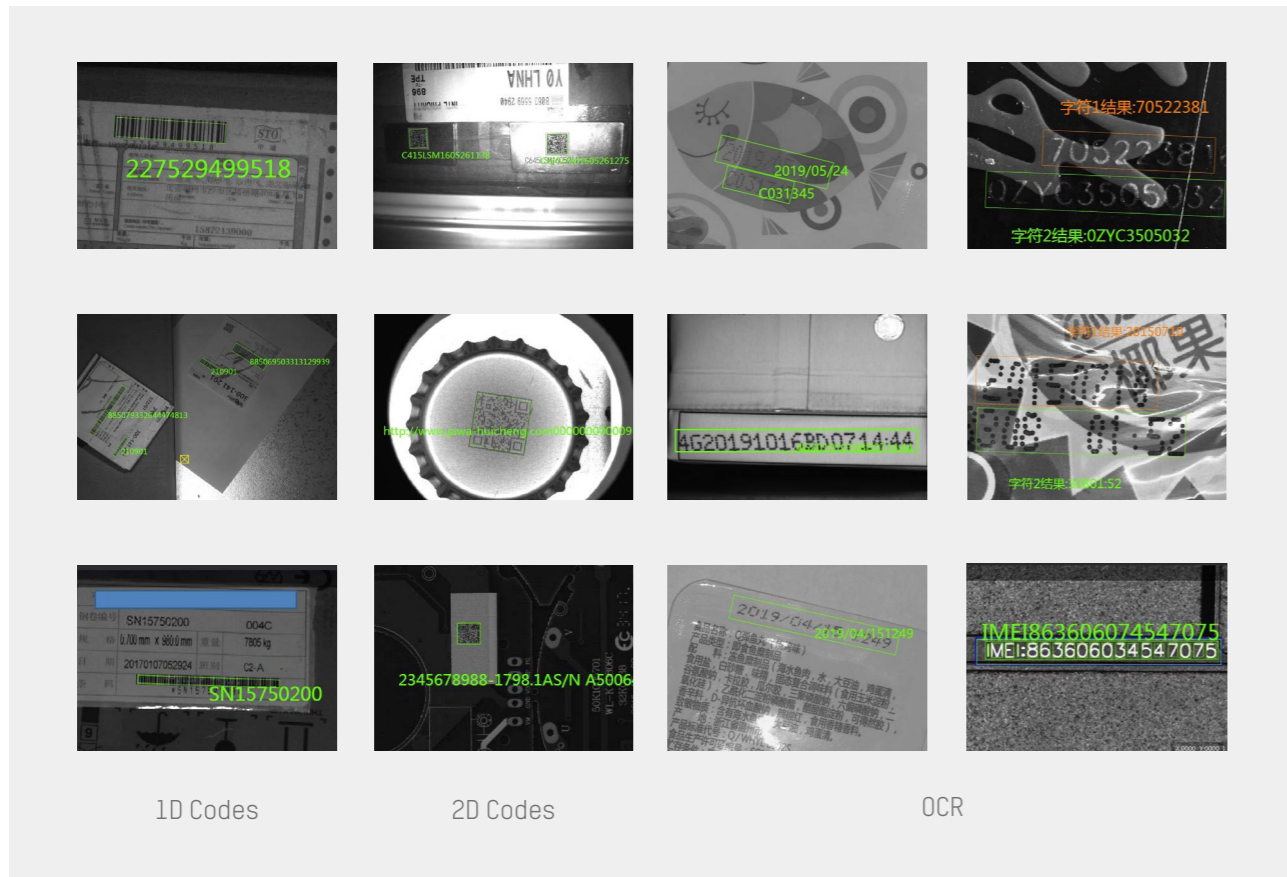

Defect Detection Tools

Accurately identify defects on the surface, shape, and contour of workpiece.

- Deep learning technology based tools can detect small surface scratches and spots, which can overcome the surface texture, color and noise interference of the workpiece.
- Accurate detection of shape and contour defects of the workpiece, which can overcome the interference of burrs, colors and noise.
- Reliable standard parts comparison tool can locate small difference in workpiece.

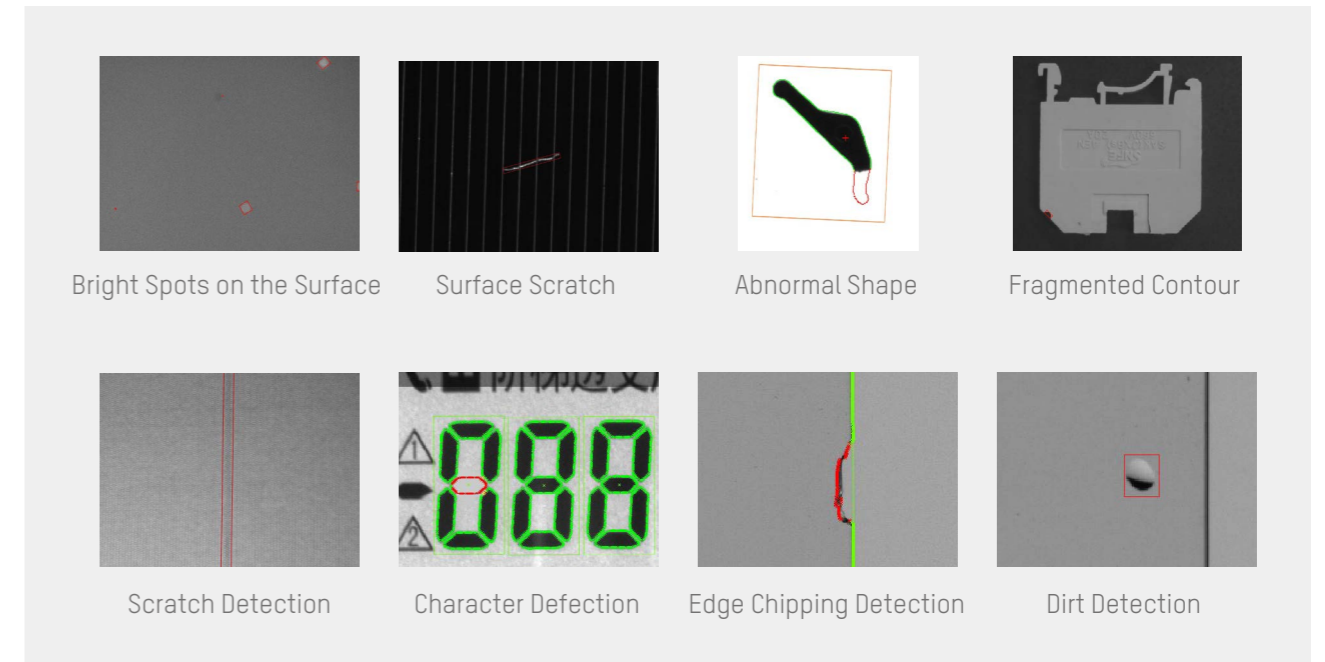

Algorithm Development Platform Tool List

Tool Box	Tool Listing
Collection	Image Source, Multiple Image Acquisition, Output Image, Image Buffer, Light
Locating	Match, Fast Match, Gray Model Match, Mark Find, Find Circle, Find Line, Blob, Caliper, Find Edge, Find Edge Width, Find Rect, Find Peak, Caliper Corner, Find Parallel Lines, Find Quadrangle, Find Line Group, Find Multiple Lines, Path Extraction, Blob Label
Measurement	L2C Measurement, C2C Measurement, P2C Measurement, P2L Measurement, L2L Measurement, P2P Measurement, Circle Fit, Line Fit, Intensity Measurement, Pixel Count, Histogram Tool, Geometry Creation
Recognition	2D BCR, BCR, OCR, DL Character Recognition GPU/CPU, DL Code Recognition GPU/CPU, DL Character Location GPU/CPU
Deep Learning	DL Image Segmentation GPU/CPU, DL Classify GPU/CPU, DL Object Detection GPU/CPU, DL Single Character Detection GPU/CPU, DL Image Retrieval GPU/CPU, DL Abnormal Detection GPU/CPU
Calibration	CalibBoard Calib, N-Point Calibration, Calib Transformation, Scale Transformation, Distortion Calib, Image Distortion Correction, Mapping Calibration, N Image Calibration
Contraposition	Camera Mapping, One Point Counterpoint, Counterpoint of Point Set, Line Alignment
Image Processing	Image Combination, Image Morph, Image Binaryzation, Image Filter, Image Enhancement, Image Math, Image Sharpness, Image Fixture, Shade Correction, Affine Transformation, Polar Unwrap, Copy Fill, Frame Mean, Normalization, Image Correction, Geometric Transformation, Image Stitch, Multiple Image Fusion
Color Processing	Color Extraction, Color Measure, Color Transformation, Color Recognition
Defect Detection	OCV, Arc Edge Defect Detection, Linear Edge Defect Detection, Arc-pair Defect Detection, Line-pair Defect Detection, Edge Combination Defect Detection, Edge-pair Combination Defect Detection, Edge Model Defect Detection, Edge-pair Model Detect Detection, Defect Contrast
Logic Tools	If Module, Branch, Branch String, Save Text, Logic Module, Format Module, Calculator, String Comparison, Shell Module, Group Module, Points Assemble, Time Consuming, Data Set, Protocol Analysis, Protocol Assembly,
Communication	Receive Data, Send Data, Camera IO Module (Modbus, EtherNet/IP, Serial Port, TCP, UDP)

Recognition Tools



Classic Application

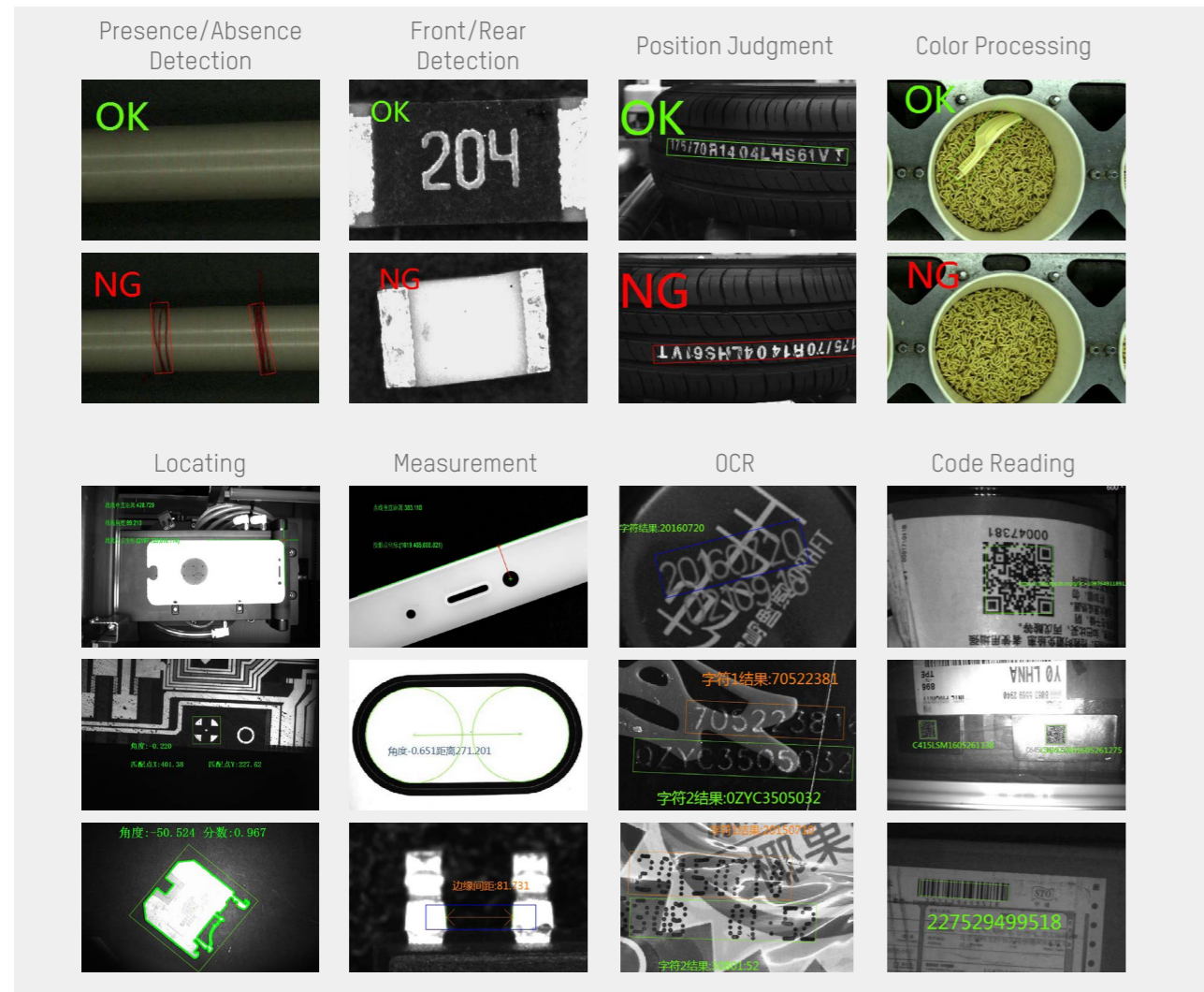

CodePlatform

Hikrobot's CodePlatform is a comprehensive code-reading software platform, including data collection, image processing, communication output, data statistics and other functions. With strong compatibility and rich functions, the platform meets most demands of common code-reading application scenarios.

Diversified Solutions

- 6 typical solutions are provided for users to select based on their actual application scenarios.
- Support user-defined solution configuration: different tool modules can be combined and extended to create new solutions.

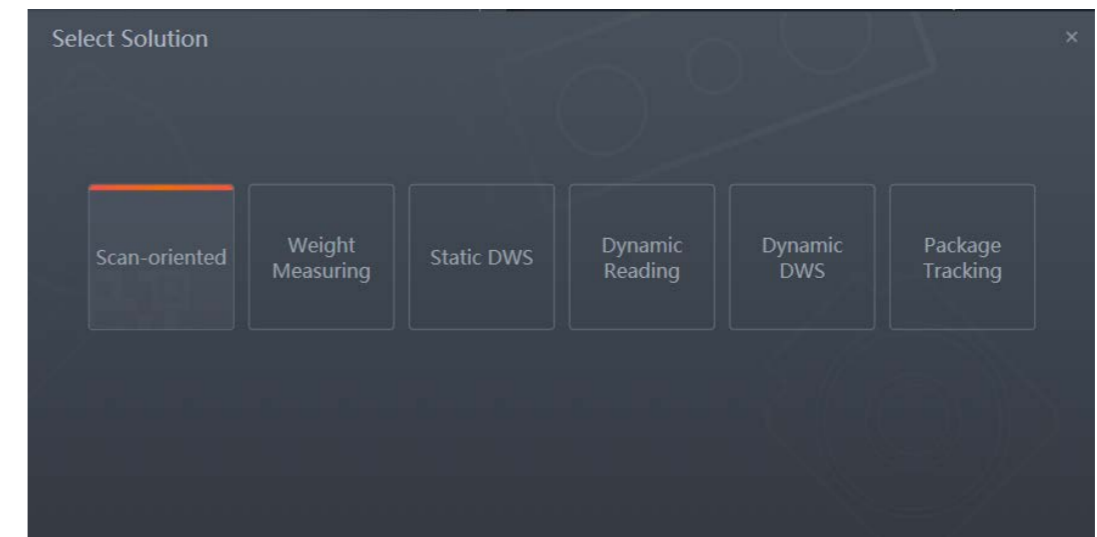

Informative Main Interface

The main interface of new style is rich and clear in information, including real-time information area, picture display area, history area, menu configuration area, quicklist area, etc.

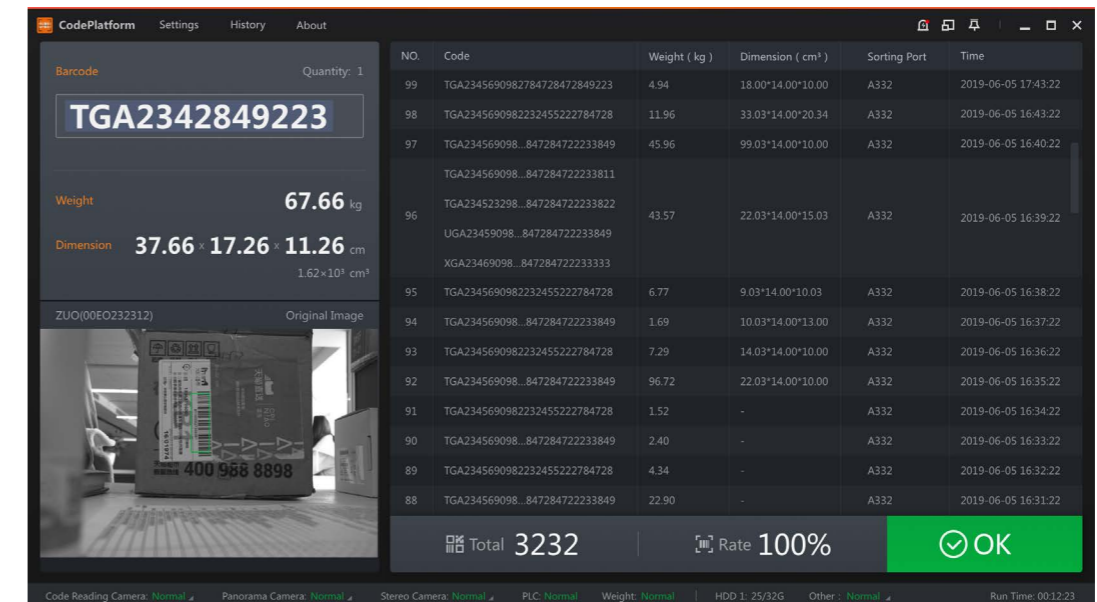

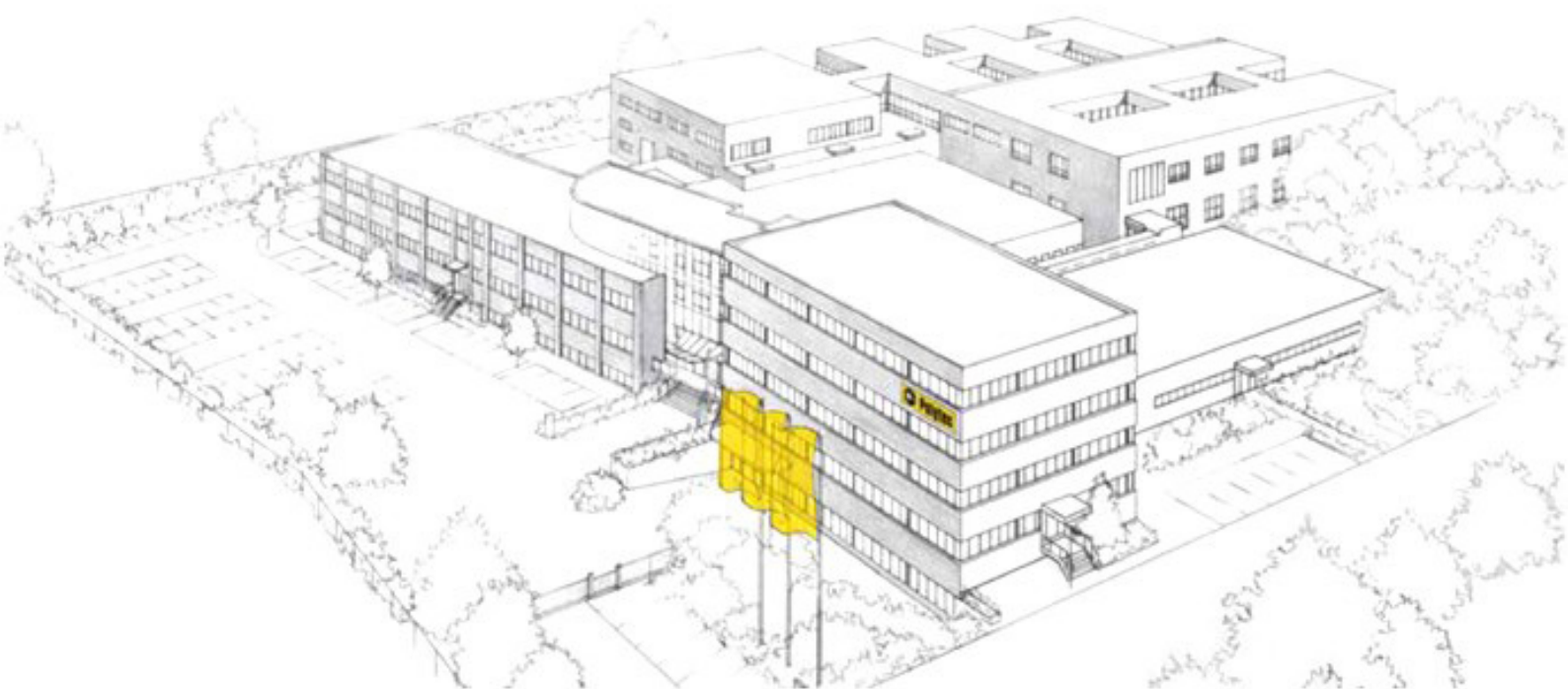

Shapping the future since 1967

Hightech for research and industry
Pioneers. Innovators. Perfectionnists.



Polytec France

Technosud II Bâtiment A, 99 rue Pierre Semard 92320 CHATILLON
Tel. +33 1 49 65 69 00, Fax. +33 1 57 19 59 60, info@polytec.fr

Contactez-nous pour un essai ou pour un devis

www.polytec.fr
www.polytecstore.fr

