



Mât fabriqué en acier S-235-JR galvanisé. Base coloris oxiron noir forge.

Option A : réhausse en inox poli brillant.

Option B : réhausse en acier S-235 JR galvanisé coloris gris RAL 9006.

Épaisseur (base, réhausse): 4 mm, 3 mm.

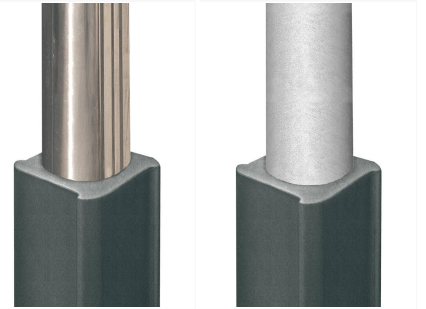

Fiche Technique -
ILDH

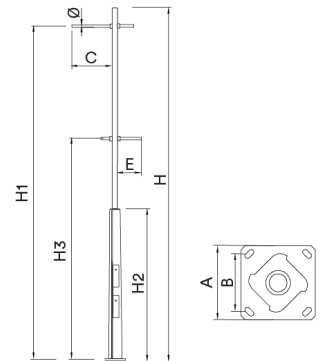

Ref.	H	H1	H2	H3	Ø	C	D	A	B					
ICNT50	5000	4500	1210	4500	60	650	-	300	200	M18x500	x	x	-	-
ICNT70	7000	6500	2500	4500	60	1050	600	400	300	M18x500	x	x	x	-
	7000	-	-	-	-	-	-	-	-	M18x500	-	-	-	x
ICNT90	9000	8500	2500	4500	60	1050	600	400	300	M18x500	x	x	x	-
	9000	-	-	-	-	-	-	-	-	M18x500	-	-	-	x
ICNT110	11000	10500	2500	4500	60	1050	600	400	300	M22x700	x	x	x	-
	11000	-	-	-	-	-	-	-	-	M22x700	-	-	-	x

[Fiche de projet](#) | [CAD](#) | [Catalogue](#) | [Image HD](#)