

SP70DQ

70-ton lifting capacity

- ▶ Engine model: US Original Cummins QSX15
- ▶ Rated power: 257 kW/2000 rpm
- ▶ Operating weight: 47.5 t

Product features

Delivering ultimate power, lift and value, the SP70DQ features an US Original Cummins QSX15 engine, load feedback, overload prevention, anti-rollover protection and precise controls. Our first offering for larger loads.



SHANTUI

VALUE THAT WORKS

Shantui Construction Machinery Co., Ltd.

ADDRESS:
No. 58, G327 Highway
Jining City, Shandong, CHINA

TEL: +86-537-2909369
FAX: +86-537-2311219
EMAIL: trade@shantui.com

SP70DQ







Technical specifications:

Overall length: 5560 mm

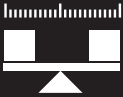
Overall width: 3780 mm

Overall height: 3640 mm

SP70DQ

	WEIGHT AND DIMENSIONS	Operating weight	47500 kg
		Maximum lifting weight	70000 kg
		Track shoe width	760 mm
		Minimum turning radius	3950 mm
		Ground length	3620 mm
		Ground clearance	485 mm
	SERVICE REFILL CAPACITIES	Fuel tank capacity	550 L
		Hydraulic tank capacity	196 L
		Engine oil	45 L
		Cooling system	121 L
	ENGINE	Rated power	257 kW
		Model	US Original Cummins QSX15
		Piston displacement	15 L
		Stroke-bore × stroke	6-137 × 169 mm
		Rated revolution	2000 rpm
	TRANSMISSION SYSTEM	Type	Hydraulic transmission
		Hydraulic torque converter	3-element, 1 stage, 1 phase
		Transmission	Planetary gear, forced lubrication
		Number of track rollers (each side)	9
		Number of carriers (each side)	2
		Travel speed 1st (forward/reverse)	3.7/4.5 km/h
		Travel speed 2nd (forward/reverse)	6.8/8.2 km/h
Travel speed 3rd (forward/reverse)	9.63/12.53 km/h		
	WORKING PUMP	Type	Duplex pump
		Displacement of large pump	201.49 ml/r
		Displacement of small pump	10.16 ml/r
		Rated working pressure	20 MPa
	PIPELAYING EQUIPMENT	Boom Length	7300 mm (9000 mm)
		Max.lifting height	6550 mm (8150 mm)
		Boom swing amplitude	1200~7200 mm (1200~8800 mm)
		Boom Line speed	0~15.6 m/min
		Gradeability	20°
		Ground press	0.086 MPa

OVERALL DIMENSIONS

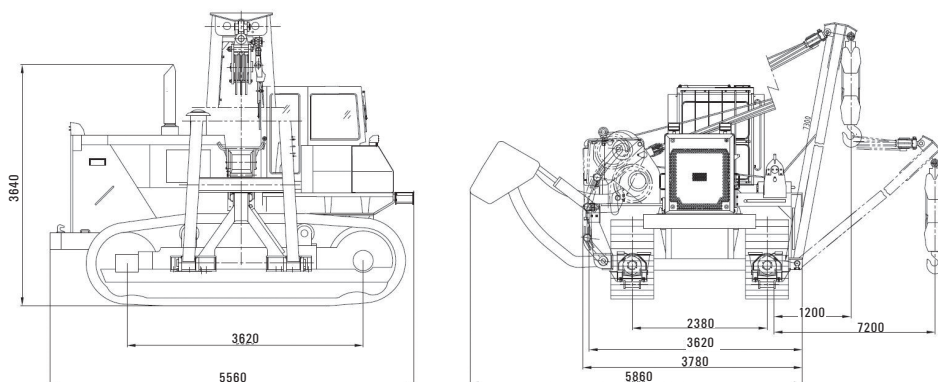

▶ THE SPECIFICATIONS ARE SUBJECT TO CHANGE WITHOUT NOTICE. THE PICTURES MAY INCLUDE OPTIONS. THE ACTUAL COLOR & APPEARANCE OF THE PRODUCT MAY DIFFER FROM WHAT IS SHOWN.

WWW.SHANTUI.COM