

AVAILABLE ROTOR PROFILES



Uni-wing: For gentle handling of media with large solids and dough-like products



Bi-wing: Robust standard variant for most applications



Multilobe: For low shear, low pulsation and gentle product handling

PROGRAM OVERVIEW

Pump model	NOVALOBE 10/0.06	NOVALOBE 20/0.12	NOVALOBE 30/0.33	NOVALOBE 40/0.65	NOVALOBE 50/1.29	NOVALOBE 60/2.1 ¹
Displacement (l/rev)	0.06	0.12	0.33	0.65	1.29	2.1
Differential pressure (bar)	16	16	16	16	16	16
Max. speed (rpm)	1,500	1,500	1,250	1,000	800	650
Max. liquid temperature	up to 95 °C, 150 °C (SIP)	up to 95 °C, 150 °C (SIP)	up to 95 °C, 150 °C (SIP)	up to 95 °C, 150 °C (SIP)	up to 95 °C, 150 °C (SIP)	up to 95 °C, 150 °C (SIP)
Rotor design	uni-wing bi-wing multilobe	uni-wing bi-wing multilobe	uni-wing bi-wing multilobe	uni-wing bi-wing multilobe	uni-wing bi-wing multilobe	uni-wing bi-wing multilobe
Surface roughness R _a (µm)	≤ 0.8 / ≤ 0.4 ²	≤ 0.8 / ≤ 0.4 ²	≤ 0.8 / ≤ 0.4 ²	≤ 0.8 / ≤ 0.4 ²	≤ 0.8 / ≤ 0.4 ²	≤ 0.8 / ≤ 0.4 ²
Connection size (mm)	25	40	50	65	80	100
Max. particle size (mm) (non-abrasive)	12	16	23	29	35	41
Max. viscosity (mPas)	1,000,000	1,000,000	1,000,000	1,000,000	1,000,000	1,000,000

¹ available summer 2017

² optional



We live our values.

Excellence • Passion • Integrity • Responsibility • GEA-versity

GEA Group is a global engineering company with multi-billion euro sales and operations in more than 50 countries. Founded in 1881, the company is one of the largest providers of innovative equipment and process technology. GEA Group is listed in the STOXX® Europe 600 Index.

GEA Germany

GEA Hilge GmbH & Co. KG

Hilgestraße 37–47

55294 Bodenheim, Germany

Tel +49 6135 7016-0

Fax +49 6135 1737

info@gea.com

gea.com

GEA VARIPUMP



GEA Hilge NOVALOBE

Rotary Lobe Pumps
for Advanced Applications



gea.com

Revolutionary Design for Viscous Media

The GEA Hilge NOVALOBE range in the GEA VARIPUMP line is specifically designed for viscous media – and for applications where gentle pumping or dosing is required.

The GEA Hilge NOVALOBE pump range meets the highest hygienic requirements and is EHEDG certified.

Robust Construction

Through the pump's robust construction the shaft overhang and clearance in the pump have been minimized. The pump's compact design and the rigid shaft geometry reduce the risk of galling to an absolute minimum. The GEA Hilge NOVALOBE range has thus been designed for a differential pressure of up to 16 bar.

Unique Rotor Mounting Design

Precision-ground cylinders for the location and accurate connection of rotors and shafts minimize play and reduce vibrations as well as noise.

Flexible Rotor Profiles

The rotor housing can be equipped with various rotor profiles. This makes it possible to adapt the GEA Hilge NOVALOBE pump to specific applications for an optimum performance in different conditions.

A Variety of Applications

The GEA Hilge NOVALOBE pumps offer extremely reliable operation and gentle product handling. The hygienic design and use of pore-free materials make the pumps suitable for a variety of applications, such as:

Food & Beverage

- Dairy
- Food processing plants
- Soft drink applications
- Confectionary and sugar
- Meat industry
- Brewery

Pharmaceutical, Biotechnology and Personal Care

- Fermentation processes
- Vaccine
- Blood products
- Enzyme production
- Cosmetics
- Personal care

Other Industrial Applications

- Paper
- Textile
- Chemical

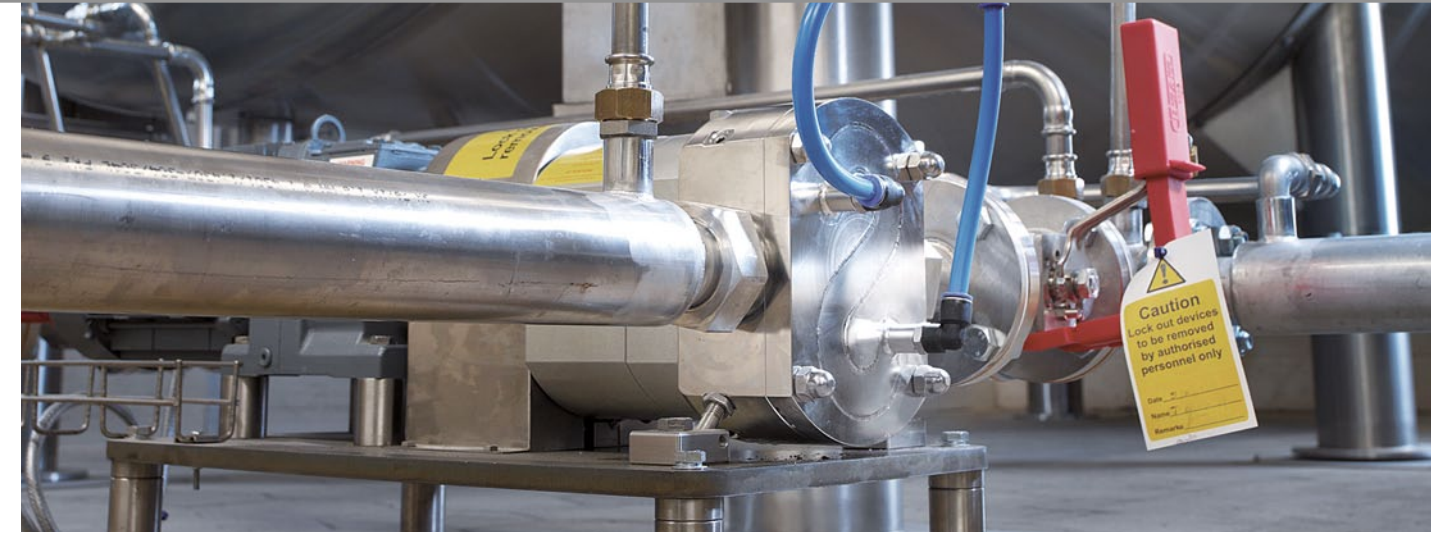

FEATURES AND BENEFITS

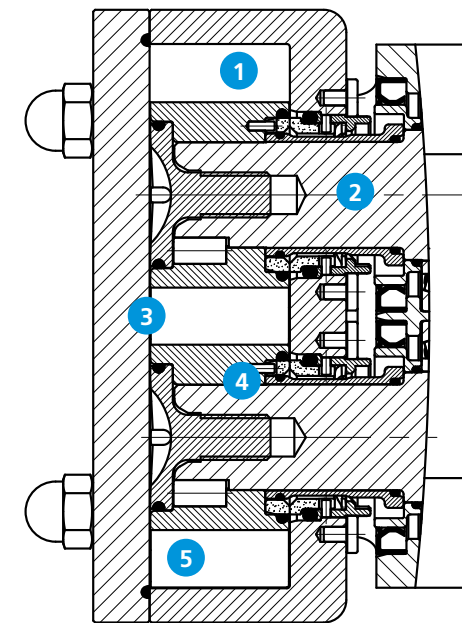

1 Flexibility

Interchangeable rotor and shaft seal designs. Various connection types

2 Robust and reliable

Large shaft diameter and compact design for high differential pressure

3 Smooth surfaces

Standard surface finish of $R_a \leq 0.8 \mu\text{m}$ for easy cleanability

4 Service-friendly

Front-loaded seals and a unique rotor fixation

5 Hygienic design

EHEDG-certified cleanability with full drainability in vertical installation

Shaft Seals

To accommodate different applications and media, GEA Hilge NOVALOBE pumps are available with different seal types:

- Single mechanical seal
- Single-flush mechanical seal
- Double mechanical seal
- O-ring seal

The mechanical seals are single inboard seals placed in the optimum position in the pump to ensure outstanding lubrication and cooling. They also comply with the hygienic design criteria in CIP and SIP processes.

Seal face materials are carefully selected to suit the specific media. Standard materials are carbon/silicon carbide with EPDM elastomers (FDA-compliant).

Connections

- Threads to DIN 11851 (standard)
- Flanges to DIN EN 1092-1 / DIN 2642 PN 16
- Sterile threads to DIN 11864-1 / DIN 11853-1
- Sterile flanges to DIN 11864-2 / DIN 11853-2
- Other connections available upon request. This includes SMS, RJT, clamp connections to DIN, ISO, Tri-Clamp etc., and special sterile threads and flanges
- Rectangular inlet for improved inlet conditions

GEA Hilge NOVALOBE Variants

- With bare shafts
- With geared motor and coupling mounted on stainless steel base frame
- With stainless steel motor shroud
- Mounted on trolley
- With horizontal or vertical ports

ADDITIONAL OPTIONS

Pressure Relief Valve

Positive displacement rotary lobe pumps will continue to build up pressure when operating against a closed valve. With this in mind, it is very important to add in a safety device to prevent accidental over-pressurization and subsequent damage to the pump or system. GEA Hilge NOVALOBE pumps can be equipped with an integrated pressure relief valve to avoid these damages.

Thermal Jackets

Thermal jackets are available for all pump sizes. This option makes it possible to heat the pump chamber and to ensure that products which solidify at ambient temperature are kept liquid. Alternatively, the thermal jackets can be used to cool the pumped media where necessary. Thermal jackets for GEA Hilge NOVALOBE are available for the rotor case and the front cover. Due to the integrated design in the pump, it is a highly efficient system without any compromise in the hygienic design and cleanability.

Aseptic Front Cover

Combining the benefits of a circulating barrier fluid and double mechanical seals, the aseptic front cover and the double mechanical seal greatly increase safety – ideal where high containment requirements apply.

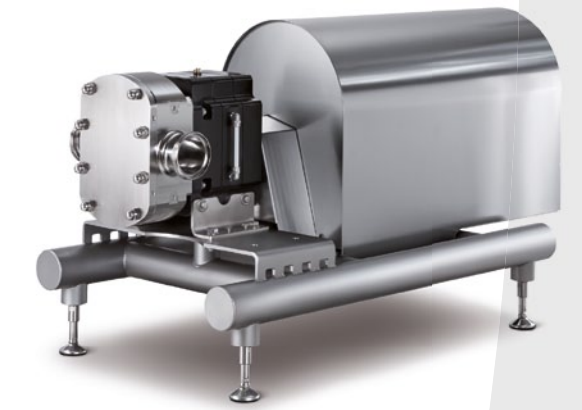

GEA Hilge NOVALOBE 60 on sterile base frame with stainless steel shroud

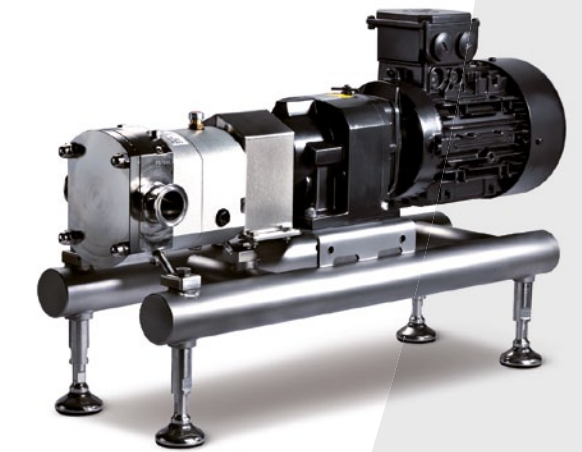

GEA Hilge NOVALOBE 20 with geared motor on sterile base frame



GEA Hilge NOVALOBE with thermal jacket



GEA Hilge NOVALOBE with pressure relief valve