



Industrie

Agro-Alimentaire

Pharmaceutique

Visserie

FGinox

www.fginox.fr

Accessoires à souder → Fonds bombés ANSI

Fonds bombés SCH10S

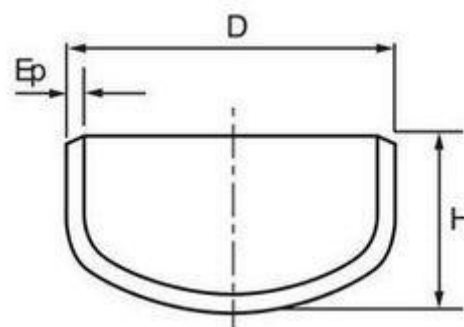

I.2CAPS_S10

DN	D	H	Ep	Poids (Kg)	Nature	Réf.	Nature	Réf.
1/2"	21,3	25,4	2,11	0,02	304L	2CAPS21S10	316L	4CAPS21S10
3/4"	26,7	25,4	2,11	0,06	304L	2CAPS26S10	316L	4CAPS26S10
1"	33,4	38,1	2,77	0,07	304L	2CAPS33S10	316L	4CAPS33S10
1"1/4	42,2	38,1	2,77	0,1	304L	2CAPS42S10	316L	4CAPS42S10
1"1/2	48,3	38,1	2,77	0,14	304L	2CAPS48S10	316L	4CAPS48S10
2"	60,3	38,1	2,77	0,18	304L	2CAPS60S10	316L	4CAPS60S10
2"1/2	73	38,1	3,05	0,31	304L	2CAPS73S10	316L	4CAPS73S10
3"	88,9	50,8	3,05	0,45	304L	2CAPS88S10	316L	4CAPS88S10
4"	114,3	63,5	3,05	0,77	304L	2CAPS114S10	316L	4CAPS114S10
5"	141,3	76,2	3,4	1,1	304L	2CAPS141S10	316L	4CAPS141S10
6"	168,3	88,9	3,4	1,6	304L	2CAPS168S10	316L	4CAPS168S10
8"	219,1	101,6	3,76	2,5	304L	2CAPS219S10	316L	4CAPS219S10

Ces accessoires à souder répondent aux normes ANSI B16.9 et ASTM A403.

Les cotes d'encombrement sont susceptibles de varier. En cas de cotes impératives, merci de nous consulter.

FGinox 3 route de Lyon 69530 BRIGNAIS France

France : T. +33 (0)437 20 17 17 F. +33 (0)437 20 00 26 E. commercial@fginox.fr

Export : T. +33 (0)437 20 17 00 F. +33 (0)437 20 21 95 E. export@fginox.fr

SAS au capital de 490 000 Euros • N° Siret : 330 458 340 00065 • Naf : 4674A • N° ident. TVA FR 15330458340



Industry

Food industry

Pharmaceutical industry

Fastener

FGinox

www.fginox.com

Welding accessories → ANSI Pipe caps

SCH10S CAPS

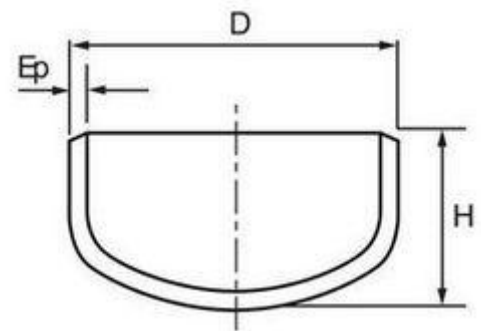

I.2CAPS_S10

DN	D	H	Ep	Weight (kg)	Nature	Réf.	Nature	Réf.
1/2"	21,3	25,4	2,11	0,02	304L	2CAPS21S10	316L	4CAPS21S10
3/4"	26,7	25,4	2,11	0,06	304L	2CAPS26S10	316L	4CAPS26S10
1"	33,4	38,1	2,77	0,07	304L	2CAPS33S10	316L	4CAPS33S10
1"1/4	42,2	38,1	2,77	0,1	304L	2CAPS42S10	316L	4CAPS42S10
1"1/2	48,3	38,1	2,77	0,14	304L	2CAPS48S10	316L	4CAPS48S10
2"	60,3	38,1	2,77	0,18	304L	2CAPS60S10	316L	4CAPS60S10
2"1/2	73	38,1	3,05	0,31	304L	2CAPS73S10	316L	4CAPS73S10
3"	88,9	50,8	3,05	0,45	304L	2CAPS88S10	316L	4CAPS88S10
4"	114,3	63,5	3,05	0,77	304L	2CAPS114S10	316L	4CAPS114S10
5"	141,3	76,2	3,4	1,1	304L	2CAPS141S10	316L	4CAPS141S10
6"	168,3	88,9	3,4	1,6	304L	2CAPS168S10	316L	4CAPS168S10
8"	219,1	101,6	3,76	2,5	304L	2CAPS219S10	316L	4CAPS219S10

These welding pipe accessories are manufactured according the ANSI B16.9 and ASTM A403 norms.

Dimensions datas are subject to change. In case of imperative dimensional datas, please contact us.

FGinox 3 route de Lyon 69530 BRIGNAIS France

France : T. +33 (0)437 20 17 17 F. +33 (0)437 20 00 26 E. commercial@fginox.fr

Export : T. +33 (0)437 20 17 00 F. +33 (0)437 20 21 95 E. export@fginox.fr

SAS au capital de 490 000 Euros • N° Siret : 330 458 340 00065 • Naf : 4674A • N° ident. TVA FR 15330458340



Industria

Industria
Agroalimentaria

Industria
Farmacéutica

Tornillería

FGinox

www.fginox.com

Accesorios soldables → Tapas para tubos ANSI

Tapas para tubos SCH10S

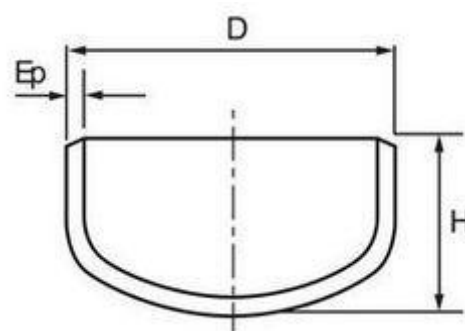

I.2CAPS_S10

DN	D	H	Ep	Peso (kg)	Natureza	Réf.	Natureza	Réf.
1/2"	21,3	25,4	2,11	0,02	304L	2CAPS21S10	316L	4CAPS21S10
3/4"	26,7	25,4	2,11	0,06	304L	2CAPS26S10	316L	4CAPS26S10
1"	33,4	38,1	2,77	0,07	304L	2CAPS33S10	316L	4CAPS33S10
1"1/4	42,2	38,1	2,77	0,1	304L	2CAPS42S10	316L	4CAPS42S10
1"1/2	48,3	38,1	2,77	0,14	304L	2CAPS48S10	316L	4CAPS48S10
2"	60,3	38,1	2,77	0,18	304L	2CAPS60S10	316L	4CAPS60S10
2"1/2	73	38,1	3,05	0,31	304L	2CAPS73S10	316L	4CAPS73S10
3"	88,9	50,8	3,05	0,45	304L	2CAPS88S10	316L	4CAPS88S10
4"	114,3	63,5	3,05	0,77	304L	2CAPS114S10	316L	4CAPS114S10
5"	141,3	76,2	3,4	1,1	304L	2CAPS141S10	316L	4CAPS141S10
6"	168,3	88,9	3,4	1,6	304L	2CAPS168S10	316L	4CAPS168S10
8"	219,1	101,6	3,76	2,5	304L	2CAPS219S10	316L	4CAPS219S10

Estos accesorios soldables cumplen con las normas ANSI B16.9 y ASTM A403

Las dimensiones pueden variar. En caso de dimensiones específicas obligatorias, póngase en contacto con nosotros.

FGinox 3 route de Lyon 69530 BRIGNAIS France

France : T. +33 (0)437 20 17 17 F. +33 (0)437 20 00 26 E. commercial@fginox.fr

Export : T. +33 (0)437 20 17 00 F. +33 (0)437 20 21 95 E. export@fginox.fr

SAS au capital de 490 000 Euros • N° Siret : 330 458 340 00065 • Naf : 4674A • N° ident. TVA FR 15330458340



Industria

Industria
Agroalimentare

Industria
Farmaceutica

Viteria

FGinox

www.fginox.com

ACCESSORI A SALDARE → FONDELLI BOMBATI ANSI

Fondelli bombati SCH10S

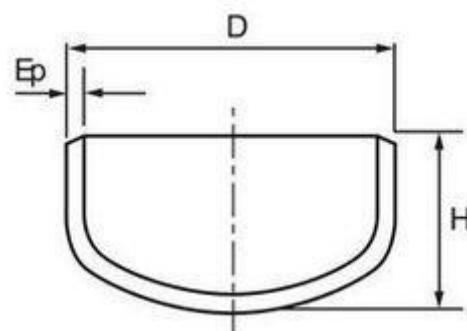

I.2CAPS_S10

DN	D	H	Ep	Peso (kg)	Tipologia	Réf.	Tipologia	Réf.
1/2"	21,3	25,4	2,11	0,02	304L	2CAPS21S10	316L	4CAPS21S10
3/4"	26,7	25,4	2,11	0,06	304L	2CAPS26S10	316L	4CAPS26S10
1"	33,4	38,1	2,77	0,07	304L	2CAPS33S10	316L	4CAPS33S10
1"1/4	42,2	38,1	2,77	0,1	304L	2CAPS42S10	316L	4CAPS42S10
1"1/2	48,3	38,1	2,77	0,14	304L	2CAPS48S10	316L	4CAPS48S10
2"	60,3	38,1	2,77	0,18	304L	2CAPS60S10	316L	4CAPS60S10
2"1/2	73	38,1	3,05	0,31	304L	2CAPS73S10	316L	4CAPS73S10
3"	88,9	50,8	3,05	0,45	304L	2CAPS88S10	316L	4CAPS88S10
4"	114,3	63,5	3,05	0,77	304L	2CAPS114S10	316L	4CAPS114S10
5"	141,3	76,2	3,4	1,1	304L	2CAPS141S10	316L	4CAPS141S10
6"	168,3	88,9	3,4	1,6	304L	2CAPS168S10	316L	4CAPS168S10
8"	219,1	101,6	3,76	2,5	304L	2CAPS219S10	316L	4CAPS219S10

La presente raccorderia a saldare è conforme alle norme ANSI B16.9 e ASTM A403

Le dimensioni d'ingombro possono variare. In caso di esigenze particolari relative alle dimensioni d'ingombro si prega di consultarci.

FGinox 3 route de Lyon 69530 BRIGNAIS France

France : T. +33 (0)437 20 17 17 F. +33 (0)437 20 00 26 E. commercial@fginox.fr

Export : T. +33 (0)437 20 17 00 F. +33 (0)437 20 21 95 E. export@fginox.fr

SAS au capital de 490 000 Euros • N° Siret : 330 458 340 00065 • Naf : 4674A • N° ident. TVA FR 15330458340



Schweißfittings → ROHRKAPPEN ANSI

Rohrkappen SCH10S

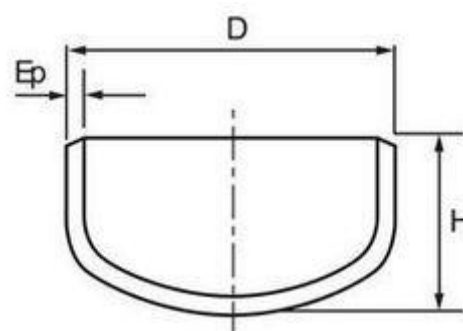

I.2CAPS_S10

DN	D	H	Ep	Gewicht (Kg)	Material	Réf.	Material	Réf.
1/2"	21,3	25,4	2,11	0,02	304L	2CAPS21S10	316L	4CAPS21S10
3/4"	26,7	25,4	2,11	0,06	304L	2CAPS26S10	316L	4CAPS26S10
1"	33,4	38,1	2,77	0,07	304L	2CAPS33S10	316L	4CAPS33S10
1"1/4	42,2	38,1	2,77	0,1	304L	2CAPS42S10	316L	4CAPS42S10
1"1/2	48,3	38,1	2,77	0,14	304L	2CAPS48S10	316L	4CAPS48S10
2"	60,3	38,1	2,77	0,18	304L	2CAPS60S10	316L	4CAPS60S10
2"1/2	73	38,1	3,05	0,31	304L	2CAPS73S10	316L	4CAPS73S10
3"	88,9	50,8	3,05	0,45	304L	2CAPS88S10	316L	4CAPS88S10
4"	114,3	63,5	3,05	0,77	304L	2CAPS114S10	316L	4CAPS114S10
5"	141,3	76,2	3,4	1,1	304L	2CAPS141S10	316L	4CAPS141S10
6"	168,3	88,9	3,4	1,6	304L	2CAPS168S10	316L	4CAPS168S10
8"	219,1	101,6	3,76	2,5	304L	2CAPS219S10	316L	4CAPS219S10

Dieses Schweißfittings entsprechen den Normen ANSI B16.9 und ASTM A403

Änderungen der Abmessungen vorbehalten. Bei zwingend vorgeschriebenen Abmessungen wenden Sie sich bitte an uns.

FGinox 3 route de Lyon 69530 BRIGNAIS France

France : T. +33 (0)437 20 17 17 F. +33 (0)437 20 00 26 E. commercial@fginox.fr

Export : T. +33 (0)437 20 17 00 F. +33 (0)437 20 21 95 E. export@fginox.fr

SAS au capital de 490 000 Euros • N° Siret : 330 458 340 00065 • Naf : 4674A • N° ident. TVA FR 15330458340