



Laboratory permeameters

User manual



Brand data laboratory permeameter

Type number :

Serial number :

Meet the difference

Contents

1. Information on this manual	3
Introduction.....	3
1. Description.....	3
2. Technical specifications.....	4
3. Safety instructions	5
4. Preparation	5
4.1 Installation	5
4.2 Choice of measuring solution	5
5. The use of permeameters	5
5.1 Samples and sampling	5
5.2 Saturation of the samples.....	6
5.3 Placing the ring samples in the ringholders	7
5.4 Determining permeability	7
5.4.1 Constant head	8
5.4.2 Falling head method.....	9
6. Processing the results	9
6.1 Determining permeability using the constant head method	9
6.2 Determining permeability using the falling head method	10
6.3 Temperature correction.....	11
7. Discussion	11
8. Application	12
9. Troubleshooting	12
10. Maintenance	13
Literature	13
Appendix:	
Derivation of formulas	14
Measuring permeability using the constant head method	14
Determining permeability using the falling head method	14
Evaporation correction	15

1. Information on this manual



If the text follows a mark (as shown on the left), this means that an important instruction follows.



If the text follows a mark (as shown on the left), this means that an important warning follows relating to danger to the user or damage to the apparatus. The user is always responsible for its own personal protection.

Text

Italic indicated text indicates that the text concerned appears in writing on the display or the apparatus (or must be typed).

Introduction

The laboratory permeameter is a laboratory tool to measure the saturated permeability of soil samples as described in NEN5789 Soil Unsaturated zone, Determination of the saturated hydraulic conductivity; ISO/FDIS 17312 Determination of the hydraulic conductivity of saturated porous materials; ISO/TS 17892-11 Laboratory testing of soil: part 11 Determination of permeability by constant and falling head and in Methods of Soil Analysis van de American Society of Agronomy en de Soil Science Society of America SSSA Book series 5. It comes in several models, suitable for 5 to 25 samples. The use of a water pump permits the set-up of a closed water system, which assures a constant water quality and temperature, and in addition saves water.

Permeability refers to the capacity of the soil to drain off water. The permeability coefficient (K-factor) is the measure of permeability and is determined on one hand by the geometry of the complex of pores, depending on the texture and structure of the soil, and on the other hand on the intrinsic features of the soil solution (viscosity and density). Saturated soil is referred to as saturated permeability.

Soil compactness, expansion and contraction, and the occupation of the absorption complex of soil minerals affect soil permeability. A heterogeneous soil may in a vertical direction have a different permeability than in a horizontal one. This is called anisotropy.

The saturated permeability of the soil is determined during geohydrological research, often preceding the planning and execution of hydraulic and agricultural engineering projects (such as drainage and irrigation). Also in environmental protection and management it is essential to have an understanding of the prevailing hydrological conditions.

The laboratory permeameter is applied to establish the horizontal and vertical permeability of separate soil layers. It forms an alternative to field research methods to determine the saturated permeability such as the auger hole method, the double ring infiltrometer or pump tests.

1. Description

The laboratory permeameter operates on the basis of the principle outlined below (see figure overleaf): by creating a difference in water pressure on both ends of a saturated soil sample and measuring the resulting flow of water the permeability can be determined.

In a closed system water is being pumped up from a storage cistern (1: see drawing on page 4), using a circulation pump (2), to an adjustable level regulator (4) through a filter (3). The regulator is connected to a plastic container (5), and has a pipe to lead back surplus water to the storage cistern. A cover closes the cistern to reduce evaporation during measuring.

In an open system the water flows directly from the main water supply into the level regulator. Since both the level regulator and the container are part of a communicating vessel the regulator will maintain the water level in the container (the water in the regulator is level with the water in the container).

A complete saturated ring sample (6) is placed in a ringholder and a sieve disc is put on top of it. The ringholder in turn is placed inside a container. A plastic siphon (7) leads the water oozing from the sample to a burette

(8). The burettes are different in length which allows easy operation of the stop cocks. A leak basin (9) catches the water from the burettes and leads it back to the storage cistern. In an open system the water is led from the leak basin to a wash stand. The effect of the siphon is that it creates a difference in water level inside and outside the ringholder. This difference induces a continuous flow of water through the sample.

A one-point (battery operated) measuring bridge is used to measure the water levels (see figure below). The measuring bridge measures the height h (see drawing at the right) of the water column. Which in fact is the difference between the water level in the container and inside the holder of the sample rings.

By collecting the drained off water in a burette during a fixed period of time, the permeability coefficient (K-factor) of a sample can be established by applying a formula.

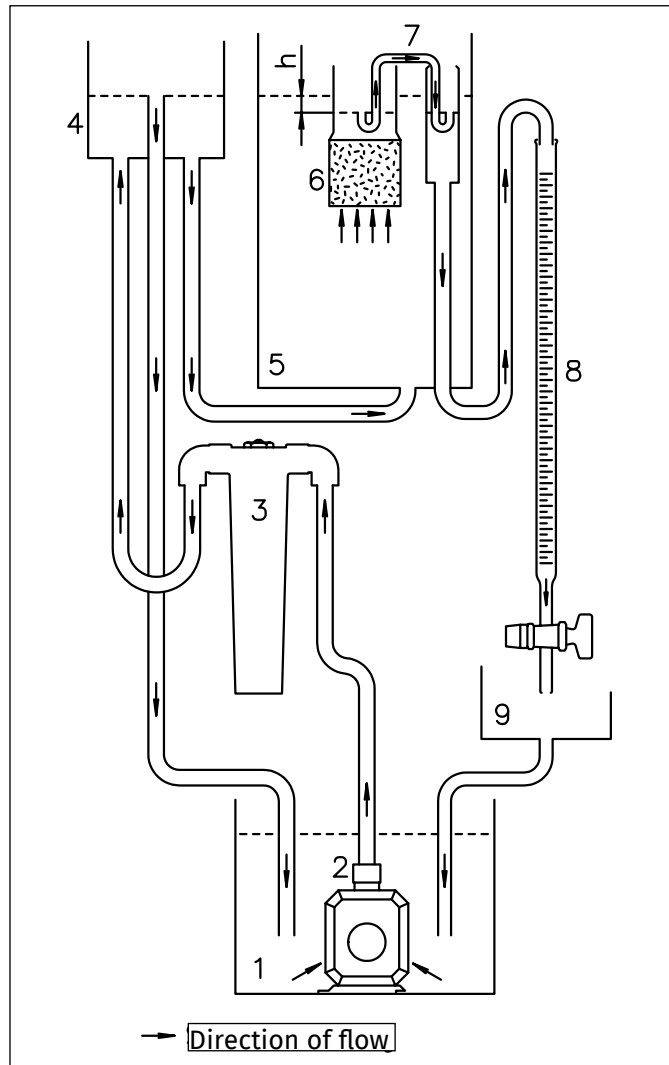
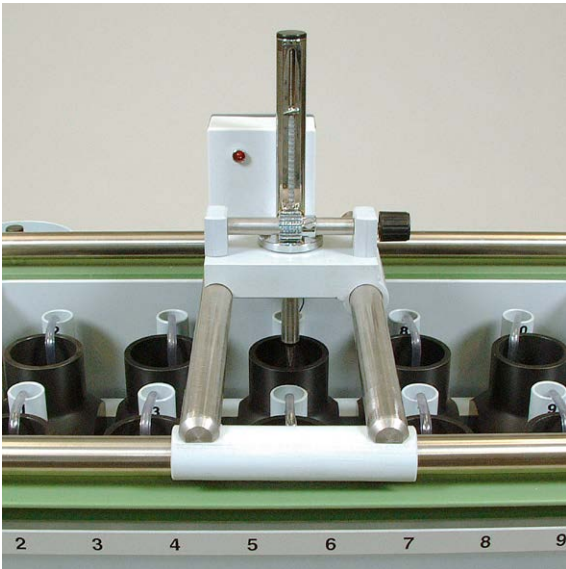

The permeameter is available in several models of different dimensions. The size depends on the number of soil samples for simultaneous measuring of permeability. Models may contain 5, 10 or 25 samples. The standard permeameter is suitable for holding samples with a 53- and 60-mm diameter.

2. Technical specifications

Permeameter models

Open system	Sample rings \varnothing 53 and 60 mm	5, 10 or 25 samples
Closed system	Sample rings \varnothing 53 and 60 mm	5, 10 or 25 samples

Pump

Type	Eheim 1048
Power rating	230 V, 50 Hz
Power	10 W
Capacity	10 liter per minute
IP67	Up to 1 meter (suitable for continuous use under water to a max. depth of 1 meter)
Maximum lift	1.5 meter (it is recommended to apply a maximum lift of 1.0 meter).

3. Safety instructions



Select the correct voltages for the pump.



Do not place the pump over 1 meter below the water level (see 2.1 Technical specifications).



Caution when handling the burette's stop cock. When exercising too much power the burette may break.

4. Preparation

4.1 Installation

Prepare the permeameter for use as follows:

1. Setup the permeameter at spirit level. If necessary, place it on an elevation.
2. Fill the storage cistern with water.

An open system is ready for use now. For a closed system:

3. Connect the pump.
4. Remove the air from the pipes. Attach the tube filled with water, between pump and filter to the filter.

4.2 Choice of measuring solution

The closed system offers the possibility to measure with solutions other than running water. It is recommended to use a measuring solution that is practically identical to the original soil solution.

To handle soil samples taken from a salty environment a salt solution is required to prevent an exchange of cations to the exchange complex of soil particles. The soil sample permeability will decrease when the electrolyte concentration is lowered. A high concentration of Na⁺ -ions may cause clay particles to disperse, thereby clogging up the capillaries and reducing permeability.

In all cases it is recommended not to use demineralised or distilled water.

5. The use of permeameters

5.1 Samples and sampling

To determine permeability with a laboratory permeameter, undisturbed soil samples in stainless steel sample rings (pF-rings) are used.

The following sample rings are suitable for use in the permeameter:

- Ring Ø 53 x 50 mm, height 51 mm, contents 100 cc
- Ring Ø 60 x 56 mm, height 40.5 mm, contents 100 cc

Sampling may be carried out at the ground surface, in auger holes and in profile pits (various soil sample ring kits and gouge auger sets and are available from Eijkelkamp Soil & Water).

Taking a ring sample should be done carefully. Make sure the rings contain the appropriate volume of undisturbed soil, and that the sample does not stick to the cutting edges. Disturbed samples are not suitable for measuring.

Obtaining representative data requires a sufficient number of samples. In homogeneous, sandy deposits, triplicate sampling will suffice. However, in heavy clay soils the soil structure is of great importance as expansion and contraction of the soil may cause crevices, leading to variation in local soil permeability. In that case sampling in clay soils should be carried out in groups of twenty or thirty.

Also the level of humidity during sampling is essential. A high level may cause the sample to clog the pores and crevices. When drying out, the clay sample may become hard and crumbly.

5.2 Saturation of the samples

After taking the samples they need to be saturated. The following methods may be followed, depending on the available soil material and research requirements:

- In a water tank
- In a desiccator (vacuum, with de-aerated water)
- In the container of the permeameter

Water tank

Place a small piece of hydrophilic gauze and a strainer cap on the bottom end of the samples. Place the samples in the water tank for saturation. The water level should remain approx. 1 cm below the bottom side of the sample.



The water level should never rise above the sample's edge; this may cause disturbance of the sample.

The period of saturation depends on the type of soil. A sandy sample will be saturated within a day, whereas poorly permeable clay will take a couple of weeks. This method does not render full saturation as in the process air is encapsulated in the pores.

Desiccator

The use of a desiccator forms a rapid method of saturation. Saturation takes place under vacuum, achieving full saturation (no encapsulation of air in the pores).

De-aerate the water in the desiccator. Place the samples with hydrophilic gauze attached, under vacuum in the desiccator for approx. 15 minutes to saturate them with de-aerated water. The samples will be fully saturated after 12 hours.

Container of the permeameter

Saturation of the samples may also take place in the container of a permeameter. First place the ring samples in the ring holders (see paragraph 5.4). Then place the ringholders in the permeameter (paragraph 5.4) to gradually saturate them, using the adjustable level regulator. The period of saturation depends on the type of soil and varies from one to three days.



Encapsulation of air reduces the permeability, make sure to saturate the samples gradually.

5.3 Placing the ring samples in the ringholders

1. Clean the outside of the sample ring well.
2. Attach hydrophilic gauze with a synthetic O-ring to the double strainer cap. Attach the strainer cap (3) to the blunt side of the sample ring (see figure).
3. Place the sample ring (2) with the cutting edge against the (exchangeable) O-ring (1) in the ringholder (see figure). This will cause the water, during measuring, to flow through the sample as it would in a natural situation of a downward flow of water.
4. Close the bridge (5) and tighten the nylon block (4) against the strainer cap so as to press the sample ring firmly against the O-ring. The double strainer cap helps preventing deformation of the sample when the strainer cap is pressed, and ensures a free flow of water through the sample.

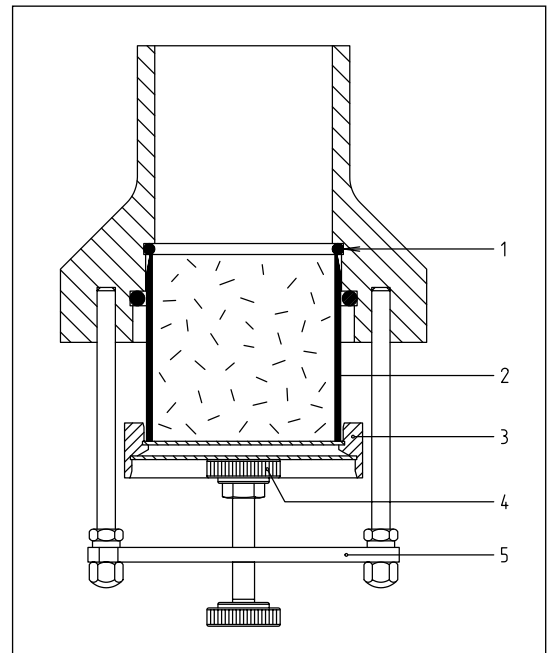

5.4 Determining permeability

Two methods to determine the permeability of soil samples can be distinguished:

- Measuring with constant water head
- Measuring with falling water head

The samples to be measured can be divided into three groups:

- a. Highly permeable samples: the water level in the ringholder is even with the water level in the container within an hour. In this case the first method can be used.
- b. Moderately permeable samples: it may take several hours before the levels are even. In most cases the samples can be measured using the first method.
- c. Poorly permeable samples: if only after one day the water appears above the sample: use the second method. If after three days no water has appeared above the sample, then for all practical purposes the permeability can be considered as nil.

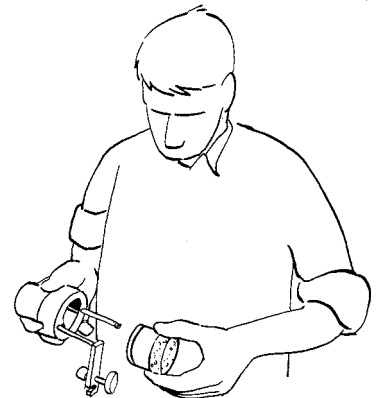

1. Prepare the permeameter for use: fill the container with water and activate the pump. If necessary, slightly tip the measuring bridge so it will not hinder placement of the ringholders.



The pump should at all times be fully submerged. It will incur serious damage when running dry. Keep the storage cistern filled with water.

2. Place the ringholders with the (nearly) saturated samples on the removable nylon platform in the container.
3. Use the level regulator to adjust the water level. When placing the samples, allow a small volume of water in the container, to increase it in a couple of hours to a desired level. This will prevent the samples to be pushed out of the ringholders by too high a water pressure.



The difference in water level created inside and outside the ringholder, equals the difference in water pressure on both sides of the sample and ensures an upward flow of water through the sample.

4. Select a method to determine the permeability. Use the scheme undermentioned and see paragraphs 5.4.1 and 5.4.2.

These methods help to determine the horizontal and vertical permeability, depending on the way the samples have been taken.

Saturated permeability [m/d] at 20°C

	10 ⁴	10 ³	10 ²	10 ¹	10 ⁰	10 ⁻¹	10 ⁻²	10 ⁻³	10 ⁻⁴	10 ⁻⁵	10 ⁻⁶
Class	High		Medium		low		Very low		Practically impermeable		
Material	Gravel	Sand		Sandy clay Silt Mix of sand, silt and clay		Fine sand	Loess Loam	Structured clay		Homogeneous clay	
Method	← Constant head →					← Falling head →					
	10 ⁶	10 ⁵	10 ⁴	10 ³	10 ²	10 ¹	10 ⁰	10 ⁻¹	10 ⁻²	10 ⁻³	10 ⁻⁴

Saturated permeability [cm/d] at 20°C

5.4.1 Constant head

This method is used with virtually any soil, apart from poorly permeable soils such as clay and peat.

1. Make sure the water level in the ringholders and in the container is even. Then place the siphons filled with water. To fill a siphon with water: move the siphon under water and slowly tilt the siphon a couple of times to make sure all the air has escaped. Place the siphon with one 'leg' in the ringholder and with the other in the numbered synthetic pipe.

The water above the sample in the ringholder will fall to the level of the siphon. Drained off water will flow into the pipe and will, the moment the pipe is filled, leak from the outflow opening of the burette (only if the level of the outflow opening is below the water level in the container). The outflow opening's level is adjustable.

2. Adjust the water level in the container to a required position by sliding the level regulator up or down. When measuring, a constant level difference (h) should be maintained inside and outside of the ringholder. This will vary, depending on the soil permeability, between 2 mm for highly permeable soils to 20 mm for poorly permeable soils.



It is recommended to determine permeability at the smallest possible level difference.

3. Measure the volume of water flowing through a sample in a unit of time. Close the stop cock on the burette and read at eye level the initial water level (in ml). Read the water level in the burette again after some time. The flow is stationary when during a unit of time a constant volume of water flows through the sample. Empty the burette by opening the stop cock and flush the water into the leak basin.



Caution when handling the burette's stop cock. When exercising too much power the burette may break.

- Slide the measuring bridge above the required spot using both hands. The measuring bridge holds a water level meter operated by a light signal. Turn the rotary knob to move the metering pin downwards. The moment the measuring point touches the water level, the light will flare and the water level can be read (0,5-mm accuracy). Similarly, the water level in both the container and in the ringholders can be read. The measured water level difference is used for every sample to calculate the saturated permeability coefficient (see Chapter 6).

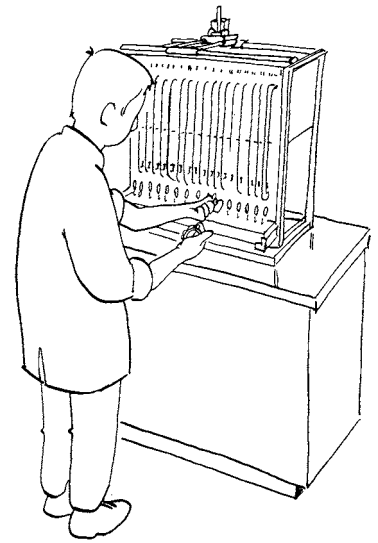

5.4.2 Falling head method

This method is used to measure low permeability in f.i. clay or peat samples. In this case the siphon is not used.

The basic difference with the method outlined in paragraph 5.4.1 is that here the change in water level difference (∂h) is measured during a certain time interval (∂t), and not the volume of drained off water.

- Make sure the water level in the ringholder and in the container is even. This may take (also for a fully saturated sample) days and even weeks.
- Lower the water level in the ringholder to just above the sample. Use a siphon or a pipette for this purpose.
- Use the measuring bridge (see previous paragraph, step 4) to measure the water level in the ringholder. This is the initial level. Put a cover on the container to prevent evaporation. Measure the water level again after a certain period of time (final level). Also measure the water level in the container. The change in water level difference is used in the calculations in paragraph 6.2.

Since the water in the container is in direct contact with the air, a certain degree of evaporation should be considered (see 6. Processing the results).

6. Processing the results

6.1 Determining permeability using the constant head method

Darcy's Law is used to calculate the K-factor when applying the constant head method to determine permeability. (see Appendix for derivations and formulas)

Darcy's Law states:

$$V = K \cdot i \cdot A \cdot t$$

Whereas:

V = volume of water flowing through the sample	(cm ³)
K = permeability coefficient or "K-factor"	(cm/d)
h = water level difference inside and outside ringholder	(cm)
L = length of the soil sample	(cm)
i = permeability rise gradient, or: h / L	(-)
A = cross-section surface of the sample	(cm ²)
t = time used for flow through of water volume V	(d)
(d = time dimension day)	

During measuring (paragraph 5.4.1) the following parameters have been determined:

- L and A : constants, depending on the type of sample ring used.
- V : volume measured in the burette (1 ml = 1 cm³)
- t : length of time lapse
- h : calculated with the water levels measured with the water level meter.

👉 **Calculate the K-factor as follows:**

$$K = \frac{V \cdot L}{A \cdot t \cdot h}$$

👉 **When filling in the formulas make sure the various parameter unities match. It is recommended to express K in (cm/d) or in (m/d).**

6.2 Determining permeability using the falling head method

Darcy's Law is used to calculate the K-factor when applying the falling head method to determine permeability (see Appendix for derivations and formulas). However, since the flow rate and the permeability rise change over time, an adjusted version of Darcy's Law is used.

Whereas:

- V = volume of water flowing through the sample (cm³)
- K = permeability coefficient or 'K-factor' (cm/d)
- A = surface of a cross-section of the sample (cm²)
- h = water level difference inside and outside ringholder (cm)
- L = length of the soil sample (cm)
- t = time between beginning and end of the measuring (t₂ - t₁) (d)
- a = cross-section surface of a ringholder (cm²)

During measuring (paragraph 5.4.1) the following parameters have been determined:

- L, A and a : constants, depending on the type of sample ring used.
- V : volume measured in the burette (1 ml = 1 cm³)
- t₂-t₁ : time interval between beginning and end of the measuring.
- h₁ and h₂ : water level difference inside and outside the ringholder at respectively t₁(start) and t₂(end).

Since this measure may take several days and the water surface is in direct contact with the atmosphere, and in view of the rather poor permeability of the samples, evaporation of water in the ringholder should not be ignored (despite the use of a cover). A change in water level difference may in the case of very poor permeability be wholly ascribed to evaporation. To correct for evaporation a correction is made using the average value for water level difference (see also Appendix).

x : evaporation factor (literature value): 0.0864 cm/d or 0.000864 m/d

👉 **Calculate the K-factor as follows:**

$$K = \frac{a \cdot L}{A \cdot (t_2 - t_1)} \cdot \ln \frac{h_1}{h_2} + \frac{x \cdot a \cdot L}{A \cdot \sqrt{h_1 \cdot h_2}}$$

👉 **When filling in the formulas make sure the various parameter unities match. It is recommended to express K in (cm/d) or in (m/d).**

L Length of soil sample in cm

a surface of cross section of sample ring

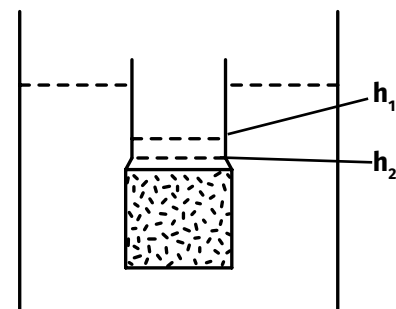

A surface of cross section of sample in cm²

6.3 Temperature correction

As mentioned earlier in the Introduction the permeability of the soil is also determined by viscosity of the soil solution. Viscosity (syrupiness) depends on the temperature (see table). The laboratory water temperature varies from 18 to 22°, whereas the average groundwater temperature is 10°. In wintertime the temperature may fall to 5° (values for moderate climates, in other regions other values). Therefore, for certain applications the permeability will have to be corrected for the viscosity of the soil solution (usually water).

Temperature °C	Viscosity water (10 ⁻³ Pa.s)
5	1.52
10	1.31
15	1.14
18	1.05
20	1.01
22	0.96
25	0.89
30	0.81

Correct the K-factor for viscosity using the following formula (Wit 1963):

$$k_{10} = k_T * h_T / h_{10}$$

Whereas

k_{10}	=	corrected K-factor at 10 °C (under natural circumstances)	(cm/d)
k_T	=	K-factor at the applied temperature	(cm/d)
h_{10}	=	dynamic viscosity of water at 10 °C	(Pa.s)
h_T	=	dynamic viscosity of water at T °C	(Pa.s)

7. Discussion

- Despite the accuracy of the laboratory permeameter, the measured values for the saturated permeability will always deviate from field conditions, which is caused by inaccuracies in sampling and by spatial variability in the field.
- The measuring results reflect the permeability of the soil where the sample was taken. For proper mapping of the area a large number of samples will have to be taken.
- The methods used here are based on Darcy's Law. However, Darcy's Law is based on homogeneous soils and a one-dimensional flow. In reality a soil will always be heterogeneous and contain crevices and macro-pores. Therefore, the assumption that samples comply with Darcy's Law can not be justified.
- The size of the samples is too small to include crevices and macro-pores. The measured permeability of clay soils will often be less than the real field values. The contribution of macro-pores to water transport well exceeds the contribution of the volume equivalent to small pores.
- The permeameter is not suitable for highly permeable soils, the reason being that it is not possible to keep a water level above the sample. The draining off speed exceeds the feeding speed.

- When using an open system in which running water is added to the measuring system dissolved gasses may accumulate in the pores, which can not be avoided. The resulting inaccuracy (a slightly lower level of permeability is read) however, is within bounds of other inaccuracies caused among other things by sampling. The use of de-aerated water is recommended.

8. Application

The laboratory permeameter is suitable for measuring the saturated permeability of undisturbed soil and ground in sample rings. The permeability coefficient or 'K-factor' can be determined for virtually all types of soils, except for highly permeable or soils susceptible to expansion and contraction. Depending on the sampling method the vertical or horizontal permeability is determined.

Saturated permeability measurement using a laboratory permeameter is applied to determine the speed of flow of groundwater in:

- Drinking water collection
- Irrigation and drainage
- Civil- and hydraulic engineering, such as the construction and reinforcement of dams and dikes
- Agricultural engineering
- Environmental research, such as the transport of polluting solutions, manure or radio-active waste in the groundwater
- Ecological surveys and nature conservation
- Agriculture and horticulture

9. Troubleshooting

- The light of the water level meter does not flare when it touches the water level. This may have a twofold cause:
 - The battery is empty. Replace it (see 10. Maintenance)
 - The circuit has been interrupted. Check the circuit. It runs from the battery via the measuring bridge's cross beams to a stainless steel tube. Small screws connect these parts. The tube, via a wire in one of the corners, makes contact with the water surface. A screw may have come undone, thereby interrupting contact, or dirt on the tube may impede contact between the cross beam and the tube.
- In a closed system insufficient water circulates. Possible causes are:
 - The pump runs dry. Fill the storage cistern with water.
 - The tubes of the level regulator or of the leak basin do not lead to the storage cistern causing loss of water. Lead the tubes through the opening into the storage cistern.
 - There is air in the tube between the filter and the level regulator. Lift the level regulator to remove the air from the tube.
- No water feeds into the burette. Possible causes are:
 - The siphon contains air. Submerge the siphon and tilt it slowly. Repeat until all air has escaped. Hold the siphon in the middle and remove it straight up from the water. Place it with one 'leg' in the ringholder and with the other in the numbered synthetic pipe.
 - The synthetic pipe is not fully filled with water. Fill it beforehand with water, or wait for a sufficiently large volume of water to pass through the samples to fill the pipe.
 - The tube under the pipe contains air. Move it to and fro to make the air escape.
 - The outflow opening on top of the burette is above the water level in the container. Lower it to below the level in the container.
 - The soil sample is un-saturated. Saturate it prior to determining the permeability using the permeameter, or wait for it to be saturated.
- The burette's stop cock is stiff. Remove the blue cap behind the stop cock and take the stop cock carefully from the burette. Apply Vaseline to the stop cock.



Make sure not to clog the outflow opening of the stop clock.

- The burette has broken off. Order a new one (order the right size!)
- The sample floods the sample ring. Attach a filter sleeve to the bottom end of the sample (between the strainer cap and the sample ring). Make sure the water level in the container rises gradually (several hours) after placement of new samples.

10. Maintenance

- Replacement of the measuring bridge battery: Remove the cover and insert a new 9 V battery. Put the cover back in place.
- Clean the instrument after use. Do not use too hot water to clean the plastic syphons because they will straighten.
- Clean the storage cistern and the filter to prevent algal growth.
- If a salt solution has been used for measuring clean all parts well to prevent the deposit of salt crystals.
- The print on the burettes is not acid resistant, do not clean with acid solutions.

Literature

Klute, A. & C.Dirksen, 1986. Hydraulic Conductivity and Diffusivity: Laboratory Methods. In: A.Klute (ed.). Methods of Soil Analysis. Part 1. Physical and Mineralogical Methods. SSA Book Series: 5.

Koorevaar, P.G. Menelik & C. Dirksen, 1983. Elements of Soil Physics. Developments in Soil Science 13. Elsevier, Amsterdam.

Wit, K.E., 1963 Meting van de doorlatendheid in ongeroerde monsters. Rapport 17. ICW, Wageningen.

Disclaimer

Nothing from this document may be copied and/or made public by means of printing, photocopy, microfilm or in any other way without the prior written approval of the publisher. Technical data can change without prior notification. Eijkelkamp Soil & Water is not responsible and/or liable for any damage and/or personal injury due to (incorrect) use of this product. Eijkelkamp Soil & Water would be pleased to receive your reactions and comments about this product and the user instructions.

Appendix Derivation of formulas

For additional information on Darcy's Law, the saturated permeability and methods of calculation and the use of the permeameter see: Klute & Dirksen 1986, Koorevaar et al 1983, Wit 1963.

Measuring permeability using the constant head method

Darcy's Law for one-dimensional, vertical flow reads as follows:

$$q = -K \cdot i = K \cdot \frac{\partial H}{\partial z}$$

The minus symbol indicates a decreasing energy state in the direction of the flow of water.

K = permeability coefficient or K-factor	(cm/d)
t = time needed for flow through of volume V through the sample	(d)
V = volume of water which flows through the sample in the measured time t	(cm ³)
Q = flow rate or 'volume flow': volume of water flowing through a sample per unit of time (or V/t)	(cm ³ /d)
q = flux or 'flow density': the volume of water per time unit and per unit-area flowing through a sample, or Q / A	(cm/d)
i = permeability rise gradient	(-)
H = permeability rise	(cm)
z = length of the column of soil through which water flows	(cm)
h = water level difference inside and outside ringholder	(cm)
L = length of the soil sample	(cm)
A = cross-section surface of the sample	(cm ²)
(d = time dimension day)	

The permeability (K) is constant in a homogeneous, water-saturated soil (such as a saturated soil sample). The flux (q) is in proportion to the permeability rise gradient (i).

When determining the saturated permeability, using the permeameter, a stationary, one-dimensional flow through the sample occurs which is influenced through the difference in pressure caused by the water level difference inside and outside ringholder. Using the permeameter to calculate the saturated permeability of a sample with cross-section A and length L applies:

$$K = \frac{Q \cdot L}{h \cdot A}$$

Determining permeability using the falling head method

When determining permeability using the falling head method, the flow rate changes with time.

The flux (q) is in proportion to the water level difference h.

The speed of change of the volume of the water flown through can be expressed as:

$$dV/dt = -K \cdot h \cdot A / L$$

As a consequence of the flow through, the height of the water level difference changes too.

The change in volume can also be expressed as a function of change in water level difference:

$$dV = a \cdot dh$$

From which can be deduced:

$$dh/h = -K \cdot A / a \cdot L \cdot dt$$

$$\frac{dh}{h} = \frac{-K \cdot A \cdot dt}{a \cdot L}$$

Integration of both sides gives:

$$K = \frac{a \cdot L}{A \cdot (t_2 - t_1)} \cdot \ln \frac{h_1}{h_2}$$

Whereas:

h_1, h_2	=	water level difference inside and outside the ringholder at resp. start (t_1) and end (t_2)	[cm]
a	=	cross section surface of the ringholder	[cm ²]
t	=	length of time lapse	[d]

Evaporation correction

The value of K brought about by evaporation in the ringholder is calculated on the basis of the falling head method for the determination of permeability. An evaporation correction factor has been added.

Evaporation in the ringholder is approx. 0,00006 cm/min. There are minor deviations. (Wit 1963).

The evaporation factor is called x and equals 0,000864 m/d or 0,0864 cm/d (which equals 0,00006 cm/min or 0,0036 cm/h).

The following formula for the 'evaporation aspect' of K reads:

whereas $x \cdot a$ represents the volume of water evaporating in the ringholder, expressed in (cm/d).

The average water level difference between t_1 and t_2 is as follows (ave = average):

$$h_{ave} = \sqrt{(h_1 \cdot h_2)}$$

which added to the falling head formula for determination of permeability results in:

$$K = \frac{a \cdot L}{A \cdot (t_2 - t_1)} \cdot \ln \frac{h_1}{h_2} + \frac{x \cdot a \cdot L}{A \cdot \sqrt{(h_1 \cdot h_2)}}$$