

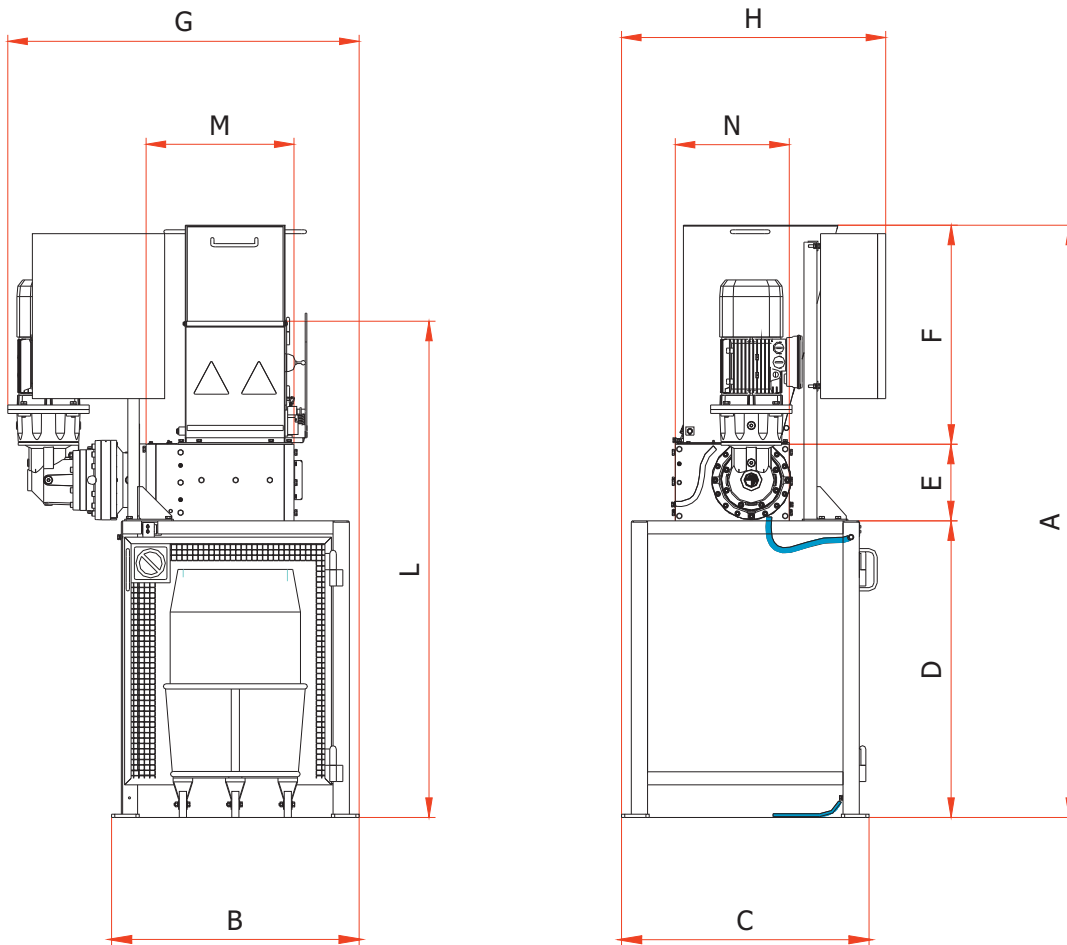

S3/3

Caractéristiques Technical data	S3/3
Chambre de broyage (mm) Shredding chamber (mm)	300x306
Lames de 12 mm (u) 12 mm blades (no.)	24
Puissance électrique (kW) Power (kW)	3
Tension (V) Voltage (V)	220/400/460
Poids (kg) Weight (kg)	340

Documentation Technique / Technical Data



S3/3	
A	1815
B	760
C	760
D	910
E	240
F	665
G	1080
H	810
L	1520
M	455
N	350

Déchets traités / Some applications:

Déchets issus des navires de pêche
Ship waste on board



Bouteilles en plastique
Plastic bottles



Canettes en aluminium
Aluminium cans



Déchets hospitaliers
Hospital waste



Circuits imprimés
PC boards



CAT1025 Rev. A 04/15

SatrindTech S.r.l.
Via Monfalcone, 122 - 20010, Arluno (MI) - Italie
Tel. (+39) 02 90 37 66 83

sales@satrindtech.com
satrindtech.com

SatrindTech France - Groupe SEREX
19, chemin de la Violette, 31240 L'Union - France
Tel. (+33) 05 62 89 08 88

contact@satrindtech-france.fr
www.satrindtech-france.fr

