

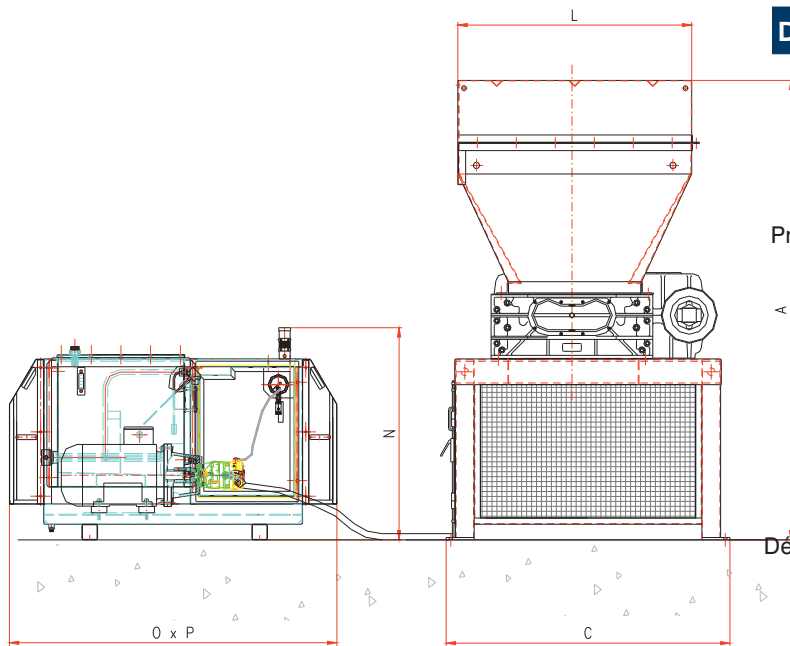







K 8/50
K10/50
K13/50

Caractéristiques Technical data	K 8/50	K 10/50	K 13/50
Chambre de broyage (mm) Shredding chamber (mm)	758x850	1008x850	1258x850
Lames de 30 mm (u) 30 mm blades (no.)	25	33	41
Lames de 50 mm (u) 50 mm blades (no.)	15	20	25
Puissance électrique (kW) Power (kW)	37	37	37
Tension (V) Voltage (V)	220/400/460	220/400/460	220/400/460
Poids (kg) Weight (kg)	3600+1100	4000+1100	4400+1100

Documentation Technique / Technical Data



Déchets traités / Some applications:

- Fûts en métal
Metal drums  60 ÷ 100 pcs/h
- Pneus véhicules légers
Car tyres  2,5 ÷ 3 t/h
- Plastiques
Plastics  0,8 ÷ 2 t/h
- Déchets industriels
Industrial scraps  1 ÷ 3 t/h
- Déchets urbains solides
Urban waste  1 ÷ 3 t/h

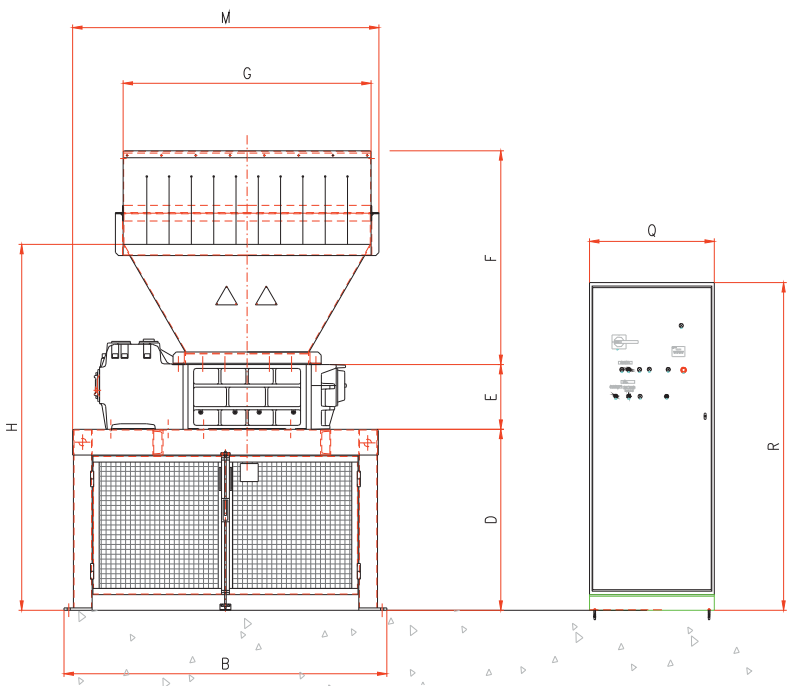

	K8/50	K10/50	K13/50
A	2945	2945	2945
B	2070	2170	2420
C	1820	1820	1820
D	1160	1160	1160
E	415	415	415
F	1370	1370	1370
G	1590	1840	2090
H	2345	2345	2345
L	1500	1500	1500
M	1964	2189	2439
N	1360	1360	1360
O	2100	2100	2100
P	1120	1120	1120
Q	800	800	800
R	2100	2100	2100

CAT1010 Rev. A 04/15

SatrindTech S.r.l.
Via Monfalcone, 122 - 20010, Arluno (MI) - Italie
Tel. (+39) 02 90 37 66 83

sales@satrindtech.com
satrindtech.com

SatrindTech France - Groupe SEREX
19, chemin de la Violette, 31240 L'Union - France
Tel. (+33) 05 62 89 08 88

contact@satrindtech-france.fr
www.satrindtech-france.fr

