

# DRAW WIRE SENSOR



## Content:

<b>Introduction</b>	<b>....2</b>
<b>Technical Data</b>	<b>....3</b>
<b>Analog outputs</b>	<b>....3</b>
<b>Digital output CANopen</b>	<b>....4</b>
<b>Electrical connection</b>	<b>....4</b>
<b>Technical Drawing</b>	<b>....5</b>
<b>Options</b>	<b>....6</b>
<b>Accessories for teachable outputs</b>	<b>....7</b>
<b>General accessories</b>	<b>....7</b>
<b>Installation and warning notices</b>	<b>....8</b>
<b>Order code</b>	<b>....9</b>

## Series MH60 for mobile hydraulics applications

### Key-Features:

- Cost-effective sensor for construction machinery
- Measurement ranges from 1 to 4 m
- extreme robust construction
- Analog outputs: Potentiometer, 0...5 V, 0...10 V, 4...20 mA, optional redundant
- teachable outputs: 0...5 V, 0...10 V, with an additional Open-Collector switching output
- Digital output: CANopen, optional redundant
- Linearity up to  $\pm 0.1$  % of full scale
- Protection class up to IP69K (suitable for close-range high pressure, high temperature spray downs)
- Temperature range -20...+85 °C (optional -40 °C)

## INTRODUCTION

The draw wire sensors of the mobile hydraulic series MH were specially developed for the demanding area of construction machines and construction equipment. The sensor can be individually configured depending on the application, in which it is used. Small adhesive and abrasive particles with small grain size can easily be removed when using the open MH versions. Seawater resistant protective grating provide a maximum protection against larger foreign objects like tree branches. In case of applications with high safety requirements, thicker stainless-steel wire ropes are available, as well as redundant, analogue outputs. This mobile hydraulics series offers the possibility the perform accurate and cost-effective distance measurement on construction machinery.

## HOUSING VARIANTS

The MH60 series comprises three different types of housings.

Common to all versions:

- Aluminium housing with bore holes for the mounting, optionally with base plate
- easy rope fixation by rope clip, secured against twisting
- stainless steel wire rope with synthetic coating
- Sensor element inside an enclosed housing
- M12 connector system or cable output
- dynamic spring drive with PA6 case

### Standard: open housing

Especially suited for applications under the conditions of fine dust and fluids.

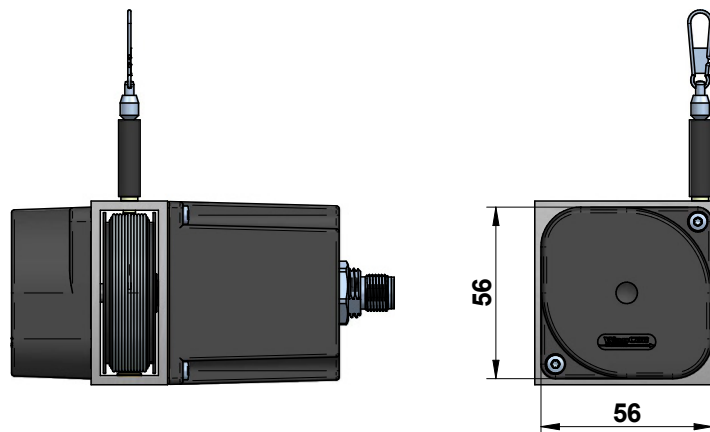

### Version C1: housing with perforated plate covering

Especially suited for applications under the conditions of dirt, particle size > 2 mm and fluids.

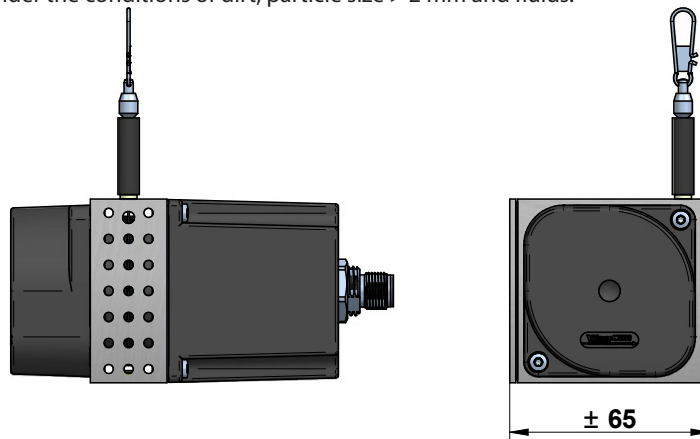

### Version C3: closed housing

Especially suited for applications under the conditions of adhesive dust, cement, concrete, clay, protection against impact and shock.

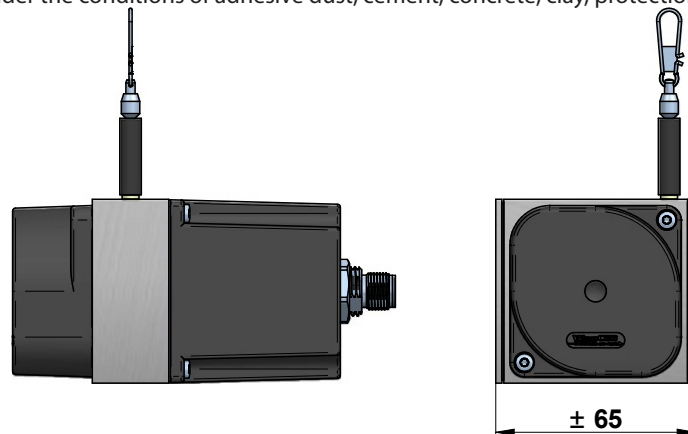

## TECHNICAL DATA

Measurement range	[m]	1			1.5			2			2.5			3			3.5			4		
Draw wire diameter	[mm]	0.5	0.7	1	0.5	0.7	1	0.5	0.7	1	0.5	0.7	1	0.5	0.7	1	0.5	0.7	0.5	0.7	0.5	0.7
Linearity	[±%]	0.5			0.5			0.5			1			0.5			1			0.5		
Improved linearity L25 <sup>1</sup>		√	√	√	√	√	√	√	√	√	-	√	-	√	-	-	-	-	-	-	-	-
Improved linearity L10 <sup>1</sup>		√	√	√	√	√	√	√	√	√	-	√	-	√	-	-	-	-	-	-	-	-
Resolution		see output types																				
Sensor element		potentiometer																				
Output signals <sup>2</sup>		potentiometer, 0...5 V, 0...10 V, 0...5 V (teachable), 0...10 V (teachable), 4...20 mA, CANopen																				
Redundant output signals		optional for: potentiometer, 0...5 V, 0...10 V, 4...20 mA, CANopen																				
Connection		connector output M12 radial or cable output radial (TPE cable, standard length 2 m)																				
Protection class		IP67, optional IP69K (only in combination with cable output)																				
Humidity		max. 90 % relative, no condensation																				
Temperature		see output types below																				
Rope extraction speed	[m/s]	max 3																				
Acceleration	[m/s <sup>2</sup> ]	max. 50																				
Extraction force	[N]	approx. 4 up to 6																				
Housing		Aluminium, spring case PA6																				
Weight	[g]	up to approx. 500 (depending on the measurement range)																				

<sup>1</sup> Options L25 and L10 only in combination with rope tube (see page 6) and not possible in combination with options S1 and S2.

The row show the possible combinations of improved linearity, measurement range and draw wire diameter.

√ = combination possible

- = combination **not** possible

<sup>2</sup> other output signals on request

## ANALOG OUTPUTS

	Potentiometer 1 kΩ	Voltage 0...5 V, 0...10 V	Current 4...20 mA	Voltage 0...5 V, 0...10 V (teachable up to 50 % MR)
Output	1 kΩ	0...5 V, 0...10 V, galvanically isolated, 4 conductors	4...20 mA, 2 conductors	0...5 V, 0...10 V, 3 conductors
Supply	max. 30 V	12...30 VDC		8...35 VDC
Recommended cursor current	< 1 μA	-		
Current consumption max.	-	22.5 mA (unloaded)	-	
Current consumption max.	-	-	-	150 mW
Output current	-	max. 10 mA, min. load 10 kΩ	max. 50 mA in case of error	max. 10 mA, min. load 1 kΩ
Dynamics	-	< 3 ms from 0...100 % and 100...0 %	< 1 ms from 0...100 % and 100...0 %	1 ms
Resolution	theoretically unlimited, limited by the noise			1 mV
Noise	dependent on the quality of the power supply	3 mV <sub>pp</sub> typical, max. 37 mV <sub>pp</sub>	0.03 mA <sub>pp</sub> = 6 mV <sub>pp</sub> at 200 Ω	3 mV <sub>pp</sub> typical, max. 37 mV <sub>pp</sub>
Inverse-polarity protection	-	yes, infinite		
Short-circuit proof	-	yes, permanent	-	yes, permanent
Working temperature	-20...+85 °C / optional: -40...+85 °C			
Temperature coefficient	± 0.0025 %/K	0.0037 %/K	0.0079 %/K	0.0016 %/K
Elektromagnetic compatibility (EMC)	according to EN 61326-1:2013			

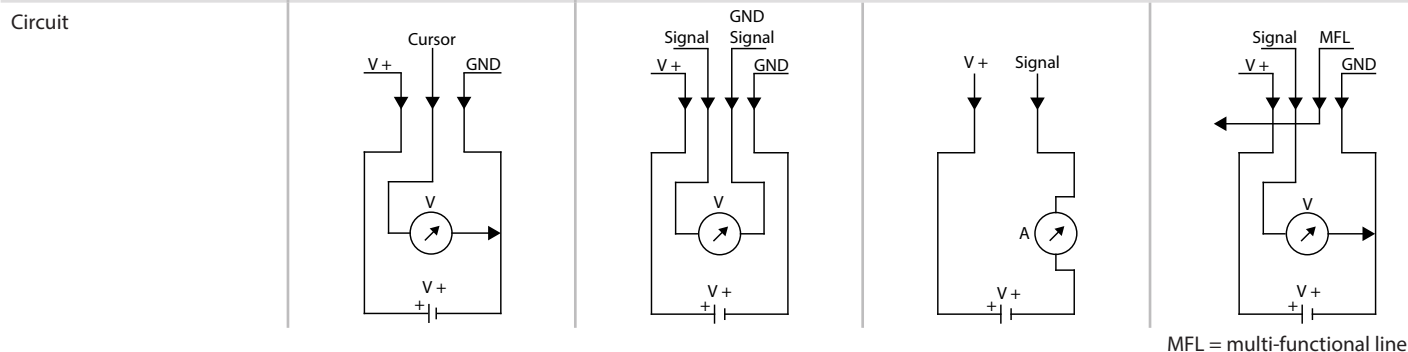

## DIGITAL OUTPUT CANopen

CAN specification		Full CAN 2.0B (ISO11898)
Communication profile		CANopen CiA 301 V 4.2.0
Device profile		Encoder, absolute linear; CIA 406 V 3.2.0
Error control		Producer Heartbeat, Emergency Message, Node Guarding
Node ID		Default: 7, configurable via SDO and Squeezer (offline configuration)*
PDO		1 x TPDO, static mapping
PDO Modes		Event-triggered, Time-triggered, Sync-cyclic, Sync-acyclic
Transmission rate		1 Mbps, 800, 500, 250, 125, 50, 20 kbps configurable via SDO and Squeezer (offline configuration)*
Bus connection		M12 connector, 5 pins
Integrated Bus termination resistor		120 Ω, connectible via SDO and Squeezer (offline configuration)*
Bus, galvanic separation		No
Supply	[VDC]	8...30
Current consumption		10 mA typical at 24 V, 20 mA typical at 12 V
Measurement rate		1 kHz with 16-bit resolution
Repeatability	[%]	±0.5, ±0.25 or ±0.1 (according to the selected linearity)
Resolution		0.002 % of measurement range
Electrical protection		inverse polarity protection
Working temperature	[°C]	Standard: -20...+85 / optional: -40...+85
Temperature coefficient	[%/K]	0.0014
EMV		DIN EN61326-1:2013, conformity with directive 2014/30/EU

\* Offline configuration via Squeezer only in combination with M12 connector 8 pins.  
For more information on the offline configuration please refer to the CANopen [manual](#).

## ELECTRICAL CONNECTION

### Analog output

- axiale cable or axiale connector M12, 4 pins

Cable colour	PIN	0...5 V, 0...10 V	0...5 V, 0...10 V (teachbar)	4...20 mA	1 kΩ
BN	1	V +	V +	V +	V +
WH	2	Signal	Signal	n. c.	Cursor
BL	3	GND	GND	Signal	GND
BK	4	GND Signal	MFL*	n. c.	n. c.

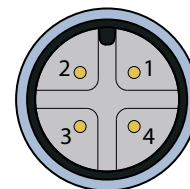

\* multi-functional line

### Redundant analog output

- axiale cable or axiale connector M12, 8 pins

Cable colour	PIN	0...5 V, 0...10 V	4...20 mA	1 kΩ
WH	1	V 1 +	V 1 +	V 1 +
BN	2	Signal 1	n. c.	Cursor 1
GN	3	GND 1	Signal 1	GND 1
YE	4	GND 1 Signal	n. c.	n. c.
GY	5	V 2 +	V 2 +	V 2 +
PK	6	Signal 2	n. c.	Cursor 2
BU	7	GND 2	Signal 2	GND 2
RD	8	GND 2 Signal	n. c.	n. c.

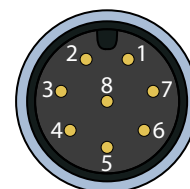

\* multi-functional line

### Cable specifications

	cable, 4 poles	cable, 8 poles
Cable type	TPE, flexible	
Direction	radial	
Length	2 m standard (other lengths on request)	
Diameter	Ø 4.5 mm	Ø 6.6 mm
Wire	0.14 mm <sup>2</sup>	0.25 mm <sup>2</sup>
Temperature	fixed installation -30...+85 °C, flexible installation -20...+85 °C	

For the assignment of the digital output CANopen (WCAN) please refer to the [manual](#).

# TECHNICAL DRAWING

## Standard: open housing

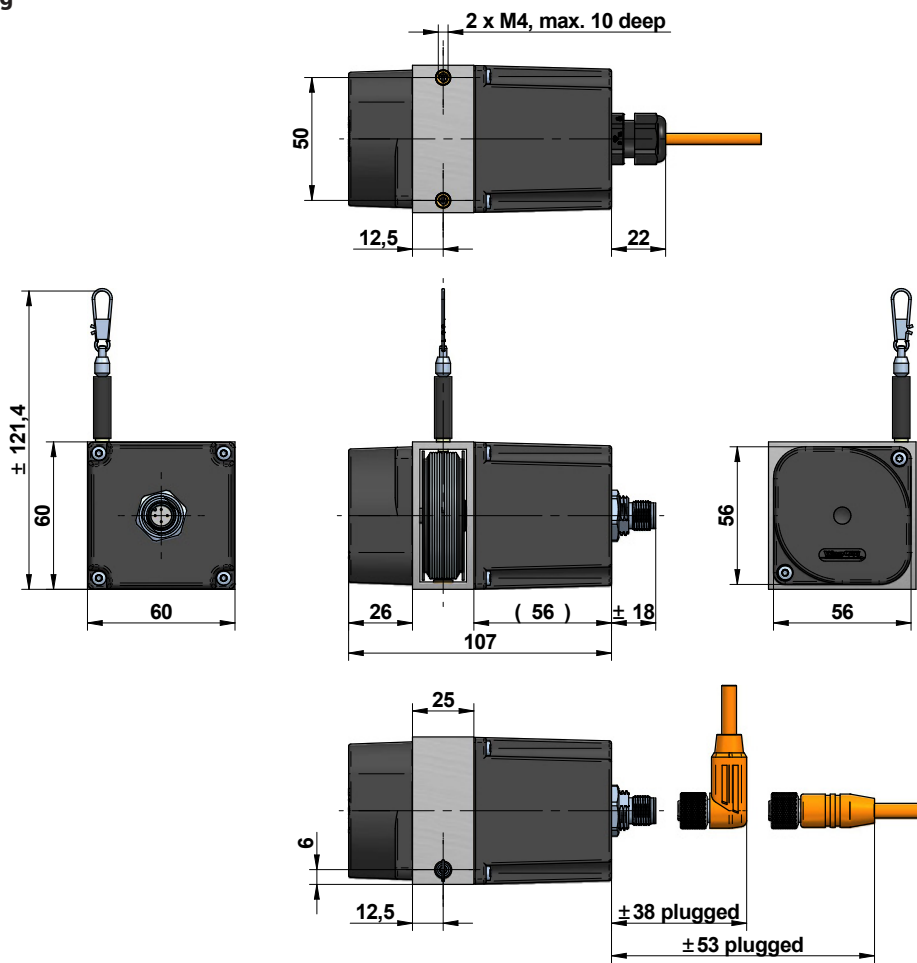

## Version with rope tube (options L10 and L25)

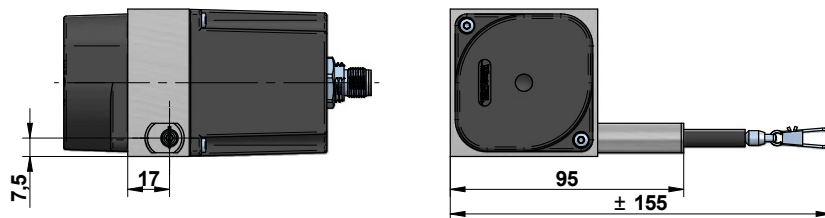

## Version with base plate (option BP)

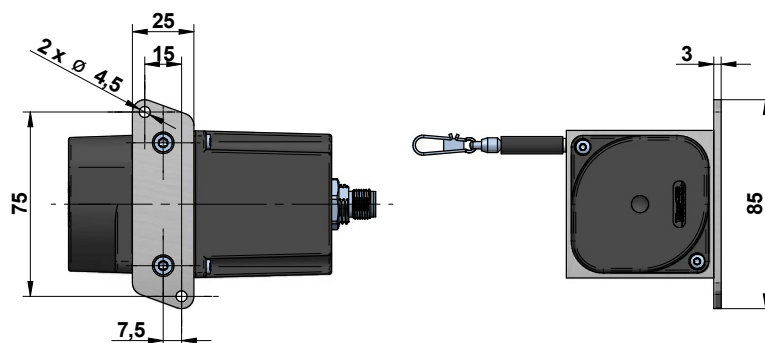

## OPTIONS

The following table gives an overview of frequently used options, with which the standard sensors can be equipped.

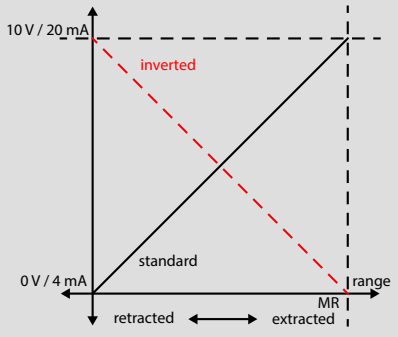
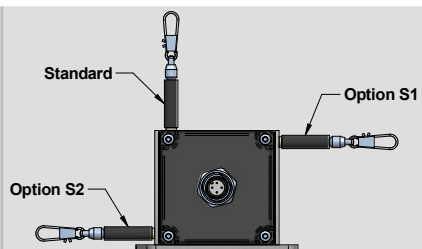
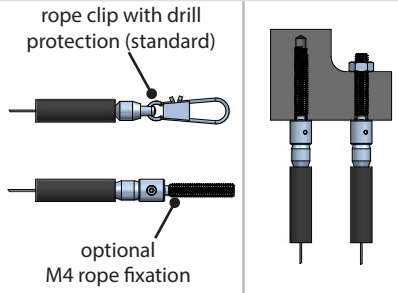
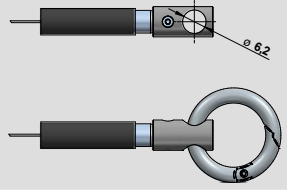
Option	Order code	Description
Improved linearity (not in combination with S1 or S2; further restriction see page 3)	L10, L25	Improved linearity 0.1 % (L10) or 0.25 % (L25)
Inverted output signal (only analog output)	IN	The analog signal of the sensor is increasing by extracting the rope (standard). Option IN inverts the signal, i.e. the signal of the sensor declines by extracting the rope. 
Redundant output signal	R1, R2, R3, R4	By using a double potentiometer the sensor delivers two independent output signals. R1: 2 x 1 kΩ R2: 2 x 0...5 V or 2 x 0...10 V R3: 2 x 4...20 mA R4: 2 x CANopen
Changed rope outlet (only in combination with C1 or C3)	S1, S2	Standard: rope outlet at the top S1: rope outlet on the right side S2: rope outlet on the left side 
Sensor housing	C1, C3	Standard: open housing C1: housing with perforated plate covering C3: closed housing
Wire rope diameter	D05K, D07K, D10K	The wire rope is made of V4A stainless steel, 1.4401 with a synthetic coating. Please choose the wire rope diameter in part two of the order code. D05K: Ø 0.5 mm (Standard) D07K: Ø 0.7 mm D10K: Ø 1 mm (not with measurement ranges 3.5 m and 4 m)
Rope fixation by M4 thread	M4	Optional, pivoted rope fixation with screw thread M4, length 22 mm. Ideal for attachment to through holes or thread holes M4. 
Rope fixation with cylindrical pin and M6 through bore	ZH, ZR	ZH: cylindrical pin with M6 through bore ZR: cylindrical pin with M6 through bore and carbide ring 
Protection class IP69K	IP69	All relevant components are completely encapsulated. Suitable for close-range high pressure or high temperature spray downs. Only in combination with cable output.
Increased temperature range Low	T40	The use of special components allow a working temperature down to -40 °C (up to +85 °C).
Base plate	BP	The MH60 is equipped with a base plate.

## ACCESSORY SQUEEZER FOR TEACHABLE OUTPUTS 5VT AND 10VT

Draw wire sensors with the analogue output versions 5VT and 10VT are equipped with teachable, internal electronics, called VT-Electronics. The signals provided by the sensor's potentiometer are digitized by the VT-Electronics. This digital information is first processed by the electronics, then transformed back and given out as an analogue output signal 0 to 5 V or 0 to 10 V.

The digitization offers two possibilities of adjustment, by which the sensor can be configured individually using the Squeezer:

1. Teaching of the measurement range. After a successful teaching process, the squeezer can be pulled off the sensor and be replaced by a standard cable or connector.
2. Setting an individual switching point. The squeezer allows the setting of an individual switching point open collector. The switching signal is emitted through the multi-functional line MFL.

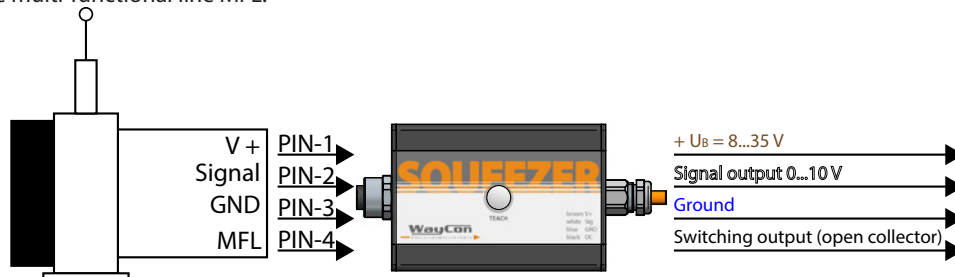

A detailed description of the functions can be found in a separate [manual](#).

### Electrical connection Squeezer

Accessory:  
Connection cable sensor to  
Squeezer:  
K4P1,5M-SB-M12

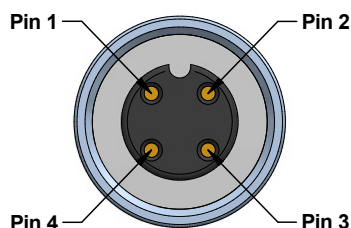

#### Connector (to sensor)

PIN 1	V +
PIN 2	Signal
PIN 3	GND
PIN 4	MFL*

#### Cable ends (to PLC)

BN	V +
WH	Signal
BU	GND
BK	NPN*

MFL = multi-functional line

\* The open collector is a NPN switching output

## GENERAL ACCESSORIES

### Deflection pulley - UR2

The rope must be extracted from the sensor vertically. The maximum variation from the vertical is 3°. A deflection pulley allows a change in the direction of the wire rope. Several pulleys may be used. The rope clip must not be guided over the deflection pulley.

- Material foot: anodised aluminium  
 Material rope wheel: POM-C  
 Mounting: by 2 hexagon socket or countersunk screws M6, vertical or horizontal mounting possible. Ball bearings: with special low temperature grease and RS-sealing.  
 Temperature: -40...+80 °C

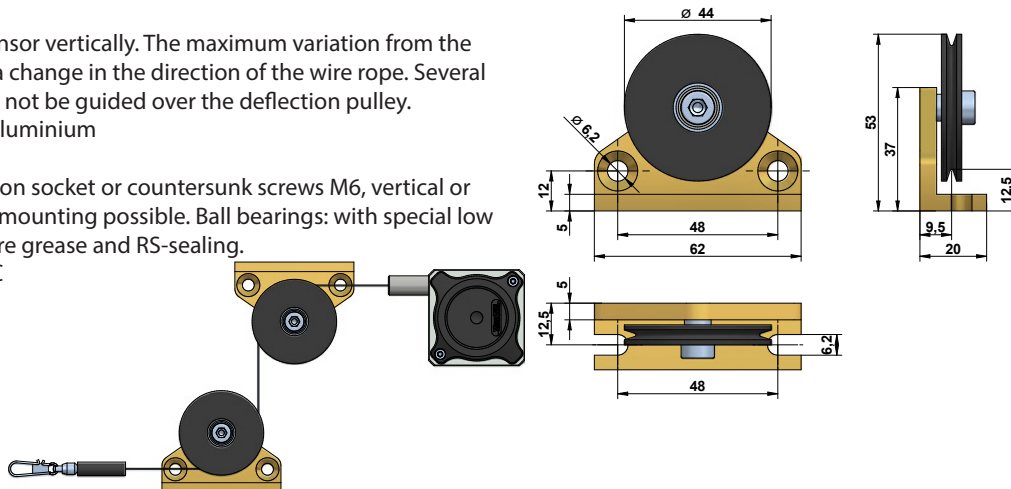

### Rope extension - SV

For bridging a greater distance between the measuring target and the sensor a rope extension can be applied. The rope clip must not be guided over the deflection pulley.

Please specify the length needed in your order (XXXX). The minimum length is 150 mm:

- SV1-XXXX: rope extension (150...4995 mm)  
 SV2-XXXX: rope extension (5000...19995 mm)  
 SV3-XXXX: rope extension (20000...40000 mm)

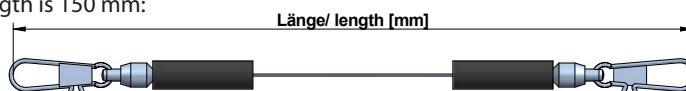

### Magnetic clamp - MGG1

Use the magnetic clamp to quickly attach the rope to metallic objects without any assembly time. A rubber coating provides gentle contact (e. g. on varnished surfaces) and prevents from slipping due to vibration. The magnet consists of a neodym core for an increased adhesive force of 260 N. The hook makes it easy to attach the rope clip.

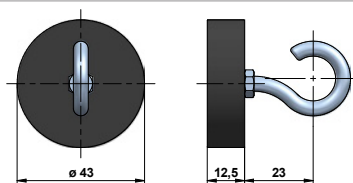

## ACCESSORIES CABLES AND CONNECTORS

### Single analog signal

#### Cable with connector M12, 4 poles, shielded

K4P2M-S-M12	2 m, connector straight
K4P5M-S-M12	5 m, connector straight
K4P10M-S-M12	10 m, connector straight
K4P2M-SW-M12	2 m, connector angular
K4P5M-SW-M12	5 m, connector angular
K4P10M-SW-M12	10 m, connector angular

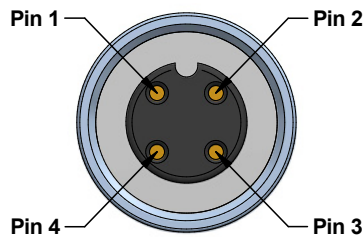

#### Mating connector M12, 4 poles, shielded, IP67

D4-G-M12-S	straight, M12 for self assembly
D4-W-M12-S	angular, M12 for self assembly
	cable passage: $\varnothing$ 4...8 mm
	wire cross-section: 0.14...0.34 mm <sup>2</sup>



PIN	1	2	3	4
Cable colour	BN	WH	BU	BK

### Digital signal CANopen

#### Cable with connector M12, 5 poles, shielded

K5P2M-S-M12	2 m, connector straight IP67
K5P2M-SW-M12	2 m, connector angular, IP67

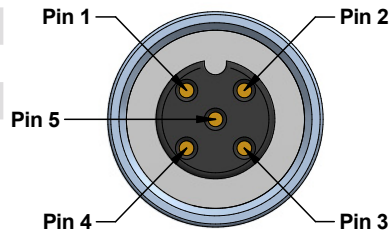

PIN	1	2	3	4	5
Cable colour	BN	WH	BU	BK	GY

### Redundant analog signal and CANopen with offline configuration via Squeezer

#### Cable with connector M12, 8 poles, shielded

K8P2M-S-M12	2 m, connector straight
K8P5M-S-M12	5 m, connector straight
K8P10M-S-M12	10 m, connector straight
K8P2M-SW-M12	2 m, connector angular
K8P5M-SW-M12	5 m, connector angular
K8P10M-SW-M12	10 m, connector angular

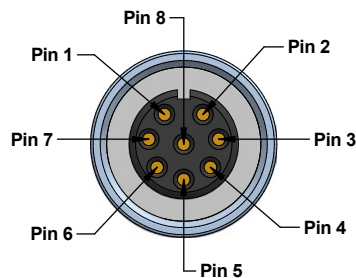

#### Mating connector M12, 8 poles, shielded, IP67

D8-G-M12-S	straight, M12 for self assembly
D8-W-M12-S	angular, M12 for self assembly
	cable passage: $\varnothing$ 4...8 mm
	wire cross-section: 0.14...0.34 mm <sup>2</sup>



PIN	1	2	3	4	5	6	7	8
Cable colour	WH	BN	GN	YE	GY	PK	BU	RD

## INSTALLATION

- Mount the sensor at the designated place by using the fixing holes before extracting the rope and before attaching the rope to the measuring target.
- Open the rope clip after the sensor is fully mounted and extract the measuring rope. Hook the rope clip on the measuring object and close the bracket of the clip. For safety reasons put a screw driver trough the clip to extract the rope.
- Check the track of the measuring target on collision with the sensor housing and on exceeding the specified measurement range. When installing the sensor make sure that the rubber stopper does not touch the rope outlet.
- Connect the electronics according to the sensor type. When laying the cables be careful not to under-run the minimal allowed bending radius of the cable (5 x cable diameter).
- The rope must be extracted from the sensor vertically.** The maximum variation from the vertical is 3°. Avoid carefully extracting the rope at an inclination, since the durability of the instrument would shorten considerably. If it is not possible to keep the limit of 3°, a deflection pulley has to be used.
- The measuring range begins after approximately 2 mm extracted rope.
- When mounting outdoors protect the sensor and the rope from icing at temperatures below 0 °C.
- Guide the rope preferably in corners or guarded in channels to prevent pollution or accidental touch.
- When operating the sensor, take care **not to let the rope snap back** by mistake or extract the rope **over the specified measurement range**, as this might destroy the sensor.
- Maintenance: These instruments are maintenance-free. If however, the rope is soiled due to adverse environmental conditions, it can be cleaned with a cloth drenched in resin-free machine oil.



## WARNING NOTICES

- Do not let the rope snap back. If the rope is retracted freely, this may lead to injuries (whiplash effect) and the device may be damaged.
- Caution when unhooking and retracting the rope into the sensor.
- Never exceed the specified measurement range when extracting the rope!
- Do not try to open the device. The stored energy of the spring drive may lead to injuries when being mishandled.
- Do not touch the rope when operating the sensor.
- Avoid guiding the rope over edges or corners. Use a deflection pulley instead.
- Do not operate the sensor if the rope is buckled or damaged. A ripping of the rope may lead to injuries or a damaging of the sensor.
- Only for standard version with open housing: the free turning of the rope drum **must** be ensured. In case the rope drum gets blocked there is a serious danger of injury and the sensor may get destroyed.

## ORDER CODE

MH60 — □ — □ — □ — □ — □

<b>Measurement range MR [m]</b> 1 / 1.5 / 2 / 2.5 / 3 / 3.5 / 4				-		<b>Version</b> Standard Sensor with options	
<b>Wire rope</b> Diameter 0.5 mm (Standard) Diameter 0.7 mm Diameter 1 mm (not MR 3,5 and 4)		D05K D07K D10K		O			
<b>Output signal</b>							
Potentiometer	1 kΩ	1R					
Voltage	0...5 V	5V					
Voltage	0...10 V	10V					
Voltage	0...5 V (teachable)	5VT					
Voltage	0...10 V (teachable)	10VT					
Current	4...20 mA	420A					
Digital	CANopen	WCAN					
Digital	CANopen offline configurable via Squeezer	WCANP					
<b>Connection</b>							
Connector output M12 axial, 4 pole <sup>1</sup>		SA12					
Cable output axial <sup>2</sup>		KA_ _					
				<b>Option</b>		<b>Description (see page 7)</b>	
				L10		improved linearity 0.1 %	
				L25		improved linearity 0.25 %	
						<b>(possible combination for improved linearity see page 3)</b>	
				IN		inverted output signal	
				R1		redundant output signal 1 R	
				R2		redundant output signal 5V, 10V	
				R3		redundant output signal 420A	
				R4		redundant output signal WCAN	
				S1		rope outlet on the right side (only in combination with C1 or C3)	
				S2		rope outlet on the left side (only in combination with C1 or C3)	
				C1		perforated plate covering	
				C3		closed housing	
				M4		rope fixation M4	
				ZH		cylindrical pin	
				ZR		cylindrical pin with carbine ring	
				IP69		Protection IP69K, only cable output	
				T40		Temperature range -40...+85 °C	
				BP		version with base plate	

<sup>1</sup> 5 pole in combination with WCAN or option R4  
8 pole in combination with WCANP or options R1, R2, R3

<sup>2</sup> only in combination with option IP69  
Length in m (Minimum 2 m)  
Examples: KR02 = 2 m, KR05 = 5 m

## GENERAL ACCESSORIES

SQUEEZER2M	accessory for VT or WCANP output, 2 m cable
SQUEEZER5M	accessory for VT or WCANP output, 5 m cable
SQUEEZER10M	accsy for VT or WCANP output, 10 m cable
UR2	deflection pulley

MGG1	magnetic clamp
SV1-XXXX	rope extension (150 mm up to 4995 mm)
SV2-XXXX	rope extension (5000 mm up to 19995 mm)
SV3-XXXX	rope extension (20000 mm up to 40000 mm)

## ACCESSORIES CABLE AND CONNECTOR

### Cable with mating connector M12, 4 poles, shielded

K4P2M-S-M12	2 m, straight connector
K4P5M-S-M12	5 m, straight connector
K4P10M-S-M12	10 m, straight connector
K4P2M-SW-M12	2 m, angular connector
K4P5M-SW-M12	5 m, angular connector
K4P10M-SW-M12	10 m, angular connector

### Mating connector M12, 4 poles, shielded

D4-G-M12-S	straight, M12 for self assembly
D4-W-M12-S	angular, M12 for self assembly

### Cable with mating connector M12, 5 poles, shielded

K5P2M-S-M12	2 m, straight connector
K5P2M-SW-M12	2 m, angular connector

### Cable with mating connector M12, 8 poles, shielded

K8P2M-S-M12	2 m, straight connector
K8P5M-S-M12	5 m, straight connector
K8P10M-S-M12	10 m, straight connector
K8P2M-SW-M12	2 m, angular connector
K8P5M-SW-M12	5 m, angular connector
K8P10M-SW-M12	10 m, angular connector

### Mating connector M12, 8 poles, shielded

D8-G-M12-S	straight, M12 for self assembly
D8-W-M12-S	angular, M12 for self assembly

### Connection cable sensor to Squeezer

K4P1,5M-SB-M12	1.5 m, 4-pole, shielded
K48P03M-SB-M12	0.3 m, shielded, 8 poles to 4 poles *

### Adapter cable WCANP to CAN-Bus

K58P03M-SB-M12	0.3 m, shielded, 8 poles to 5 poles
----------------	-------------------------------------

\* for redundant analog signal and CANopen with offline configuration via Squeezer (WCANP)

## ACCESSORY DISPLAY

### Digital display 2 channels, 0...10 V / 4...20 mA

WAY-AX-S	Touchscreen, supply: 18...30 VDC
WAY-AX-S-AC	Touchscreen, supply: 115...230 VAC

More information about digital displays can be found [here](#).