

GROUPES D'EAU GLACÉE

CHILLERS - ENFRIADORAS

PUISSANCES DE 8 À 200 kW

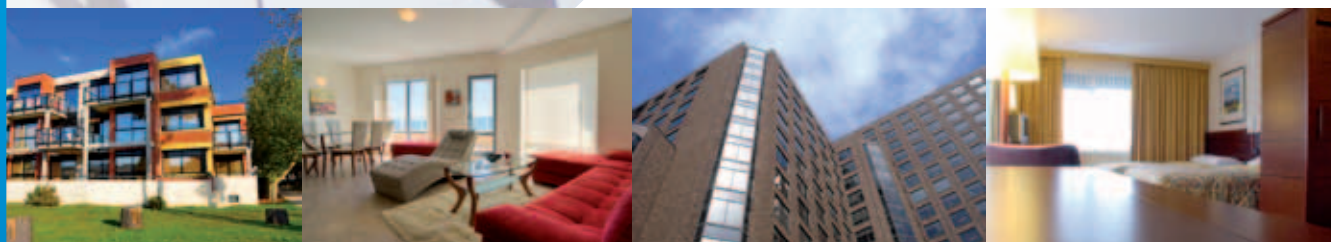

GROUPES D'EAU GLACÉE
 CLIMATISATION & RAFFRAÎCHISSEMENT
 CHÂSSIS : INOX 304 L - INSONORISÉ
 FLUIDE FRIGORIGÈNE : R410a

CHILLERS
 AIR CONDITIONING & COOLING
 CHASSIS : STAINLESS STEEL - SOUNDPROOF
 REFRIGERANT : R410a

ENFRIADORAS DE AGUA
 CLIMATIZACION & REFRIGERACION
 BASTIDOR : INOXIDABLE - INSONORIZADA
 FLUIDO REFRIGERANTE : R410a

Tableau des caractéristiques Groupe d'eau glacée

Conditions Nominales : Entrée d'air extérieur +35°C - Température d'eau glacée 7°C/12°C

Groupe d'eau glacée	PUISSANCE Frigorifique	PUISSANCE Absorbée	E.E.R	TENSION	INTENSITÉ MAX.	FLUIDE	DÉBIT D'EAU	RACCORDS	POIDS	DIMENSIONS H - L - P	Lp à 10 M
GEG - 8M	8100	2790	2,90	230/1/50Hz	24	R410a	1,4	1" [26x34]	100	81.5/110/45.5	37
GEG - 10M	10700	3550	3,01	230/1/50Hz	28	R410a	1,8	1" [26x34]	103	81.5/110/45.5	37
GEG - 13T	13300	4700	2,83	400/3+N/50Hz	12.2	R410a	2,3	1" [26x34]	132	112/110/45.5	39
GEG - 17T	16400	5360	3,06	400/3+N/50Hz	15	R410a	2,8	1" [26x34]	137	122/110/45.5	40
GEG - 20M	21400	7100	3,01	230/1/50Hz	2x28	R410a	3.6	1"1/2 [40x49]	230	160/110/45.5	40
GEG - 20T	20500	6590	3,11	400/3+N/50Hz	21	R410a	3,5	1"1/2 [40x49]	205	122/110/45.5	40
GEG - 27T	27200	8690	3,13	400/3+N/50Hz	25	R410a	4,7	1"1/2 [40x49]	207	122/110/45.5	42
GEG - 30T	30100	9640	3,12	400/3+N/50Hz	31	R410a	5,2	1"1/2 [40x49]	211	170/100/100	47
GEG - 35T	35800	11500	3,11	400/3+N/50Hz	34	R410a	6,2	1"1/2 [40x49]	285	170/100/100	47
GEG - 45T	45100	14750	3,06	400/3+N/50Hz	40	R410a	7,8	1"1/2 [40x49]	365	170/100/100	48
GEG - 57T	57200	18700	3,06	400/3+N/50Hz	48.5	R410a	9,9	2" [50x60]	460	170/200/100	51
GEG - 75T	74100	23800	3,11	400/3+N/50Hz	65.4	R410a	12,8	2" [50x60]	485	170/200/100	53
GEG - 96T	96400	30800	3,13	400/3+N/50Hz	82.5	R410a	16,6	2"1/2 [66x76]	505	170/200/100	58
GEG - 115T	114400	37400	3,06	400/3+N/50Hz	2x48.5	R410a	19,7	2"1/2 [66x76]	920	170/250/200	58
GEG - 150	148200	47600	3,11	400/3+N/50Hz	2x65.4	R410a	25,6	Bride DN 80	970	170/250/200	59
GEG - 200	190000	61600	3,08	400/3+N/50Hz	2x82.5	R410a	32,8	Bride DN 80	1003	170/250/200	61

Watt Watt E.E.R Volt A Fluide m³/h Pouces kg cm dB(A)



NOUVEAUTÉS 2011



08-10kW

13kW

20W
Monophasé

17-27 kW

30 - 45kW

57 - 96kW

115 - 200kW



Schéma d'implantation - Scheme of installation - Esquema de instalación

Vue de profil
Side view
Vista lateral

Vue de dessus
Top view
Vista superior

Vue de profil
Side view
Vista lateral

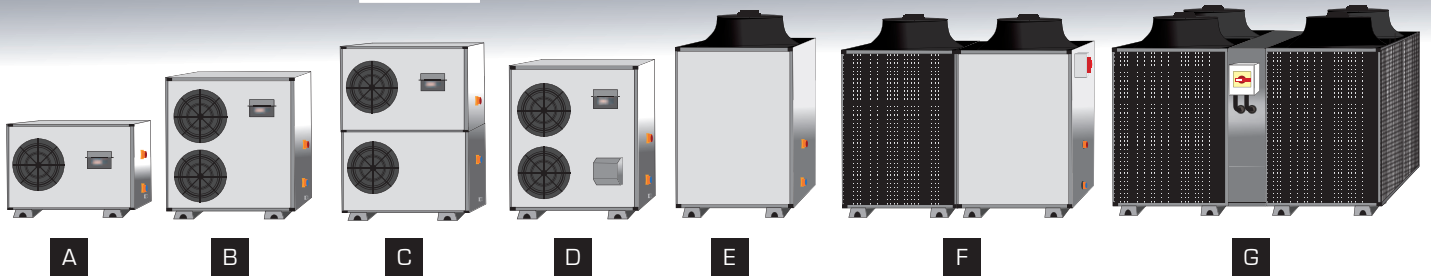
Vue de dessus
Top view
Vista superior

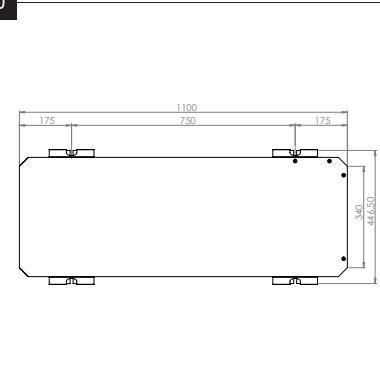
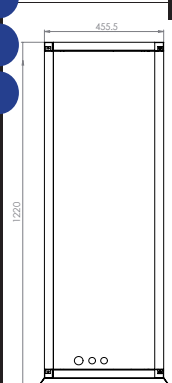
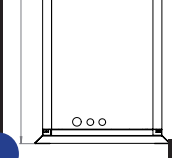
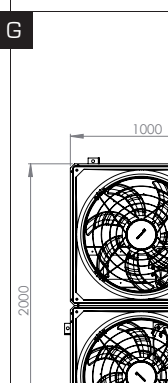
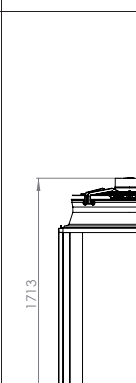
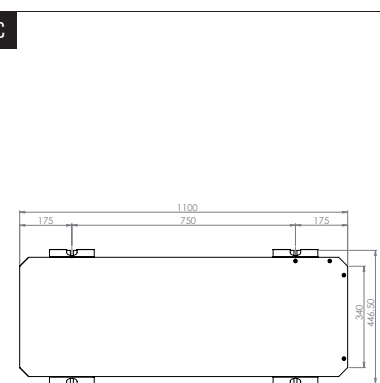
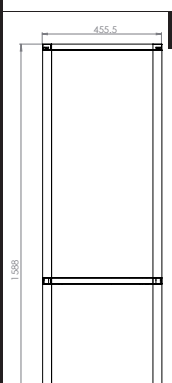
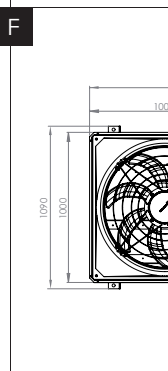
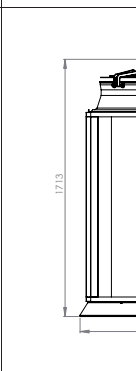
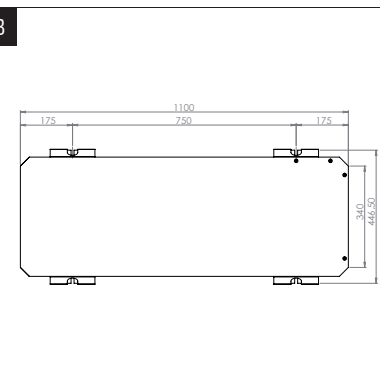
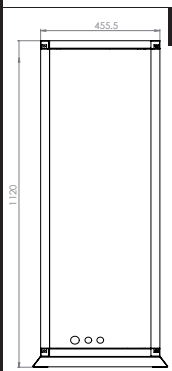
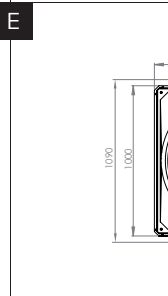
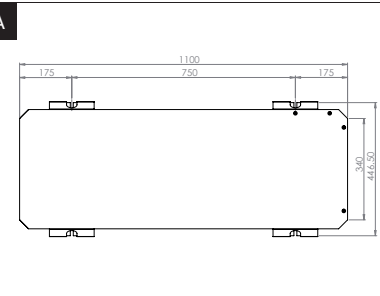
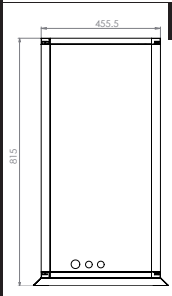

GROUPES D'EAU
GLACÉE
 CHILLERS - ENFRIADORAS