

Mod.
PDB

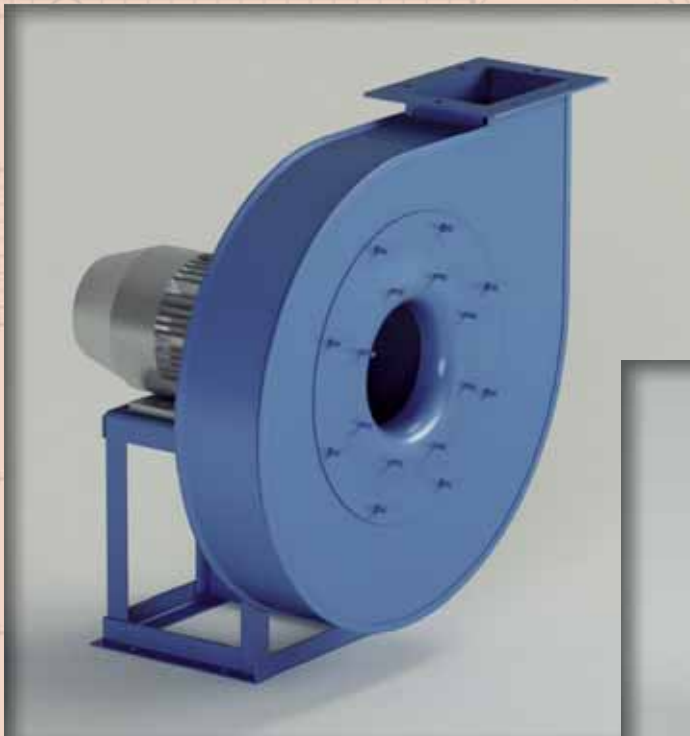

$Q = 450 \div 15000 \text{ m}^3/\text{h}$

$Q = 0.12 \div 4 \text{ m}^3/\text{s}$

$p_t = 200 \div 1000 \text{ mmH}_2\text{O}$

$p_t = 2000 \div 10000 \text{ Pa}$

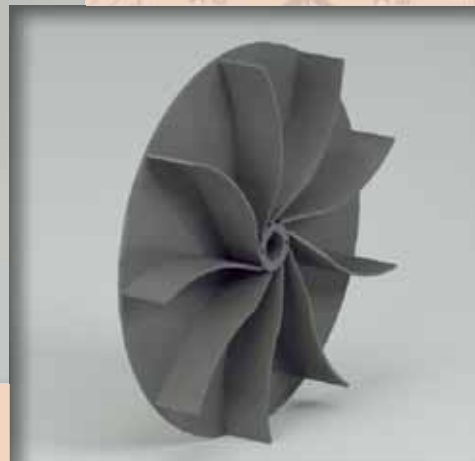

Campo di lavoro

Portate medio-basse. Pressioni medio-alte.

Tipo di pala

Pale radiali curve, aperta.

Applicazioni

Per trasporto pneumatico, di materiali solidi in miscela con aria, segatura e trucioli di legno; anche per materiali filamentosi che ostruirebbero una ventola chiusa a pale rovesce.

Esecuzioni costruttive standard

Es.1-Es.4-Es.5-Es.8-Es.9-Es.12, vedi pag. 2.5 - 2.6.

Temperature del fluido standard

-10÷+60°C. Per altre temperature vedi da pag. 1.12 a pag. 1.15.

Tipo di costruzione

Ventilatore in lamiera di Fe360, girante in Fe360 equilibrata staticamente e dinamicamente. Per altri materiali vedi da pag. 1.12 a pag. 1.15.

Dati di funzionamento

Condizioni dell'aria all'aspirazione T=20°C, 0m.s.l.m. e ρ=1.205 kg/m³.

Rumorosità

Espressa in potenza sonora L_{wA} [dB(A)] rilevata in campo libero con ventilatore canalizzato, vedi da pag. 1.43 a pag. 1.49.

Orientamenti

N°8 RD (rotazione oraria vista lato trasmissione) e N°8 LG. Ventilatore in versione imbullonata orientabile per le taglie 400-630, con supporto anteriore e quindi non orientabile dalla grandezza 710 a trasmissione, sempre orientabile nei ventilatori direttamente accoppiati senza supporto anteriore. Vedi pag. 2.7.

Costruzioni speciali

Vedi da pag. 2.20 a pag. 2.30.

Avviamento ventilatore

L'avviamento deve avvenire con ventilatore parzializzato, in funzione dell'assorbimento massimo del ventilatore.

Classi giranti

La seguente tabella fa riferimento a condizioni di lavoro standard. In condizioni di esercizio gravose si consiglia di contattare il servizio clienti di CORAL per conoscere la tipologia di girante più idonea.

■ Domaine de travail

Débits moyens-faibles. Moyennes-hautes pressions.

Type d'ailette

Ailettes radiales courbées, ouverte.

Applications

Pour transport pneumatique, de matières solides en mélange dans l'air, de sciure et de copeaux de bois, également pour des matières filamenteuses qui obstrueraient une hélice fermée à ailettes inversées.

Configurations de constructions standard

Ex.1 - Ex.4 - Ex.5 - Ex.8 - Ex.9 - Ex.12, voir pages 2.5 - 2.6.

Températures du fluide standard

-10÷+60°C. Pour d'autres températures voir pages 1.12-1.15.

Type de fabrication

Ventilateur en tôle de Fe360, turbine en Fe360 équilibrée statiquement et dynamiquement. Pour d'autres matériaux, voir pages 1.12-1.15.

Données de fonctionnement

Conditions de l'air à l'aspiration T=20°C, 0 m asl et ρ=1.205 kg/m³.

Niveau sonore

Exprimé en puissance sonore L_{wA} [dB(A)], relevé à l'air libre avec un ventilateur canalisé, voir pages 1.43 - 1.49.

Orientations

8 RD (rotation dans le sens des aiguilles d'une montre côté transmission) et 8 LG. Ventilateur en version boulonnée orientable pour les tailles 400-630, avec un support avant et donc non orientable de la grandeur 710 à transmission, toujours orientable dans les ventilateurs directement accouplés sans support avant. Voir page 2.7.

Fabrications spéciales

Voir pages 2.20-2.30.

Mise en marche du ventilateur

Le démarrage doit se faire avec un ventilateur partialisé, en fonction de l'absorption maximale du ventilateur.

Classes de turbines

Le tableau ci-dessus fait référence aux conditions de travail normales, en conditions de travail pénibles, on préconise de contacter le service clientèle de CORAL pour connaître le type de turbine le plus adapté.

GRANDEZZA VENTILATORE • Grandeur • Size • Größe • Tamaño	RPM MASSIMO • Maxi tours/min. • Max rpm • Max. U/min • R.p.m. máx.
	CLASSE I
PDB400	5300
PDB450	4750
PDB500	4250
PDB560	3750
PDB630	3350
PDB710	3000
PDB800	2950
PDB900	2350
PDB1000	2100

VALORI VALIDI FINO A 60°C

• Valeurs valables jusqu'à 60°C • Values valid up to 60°C
• Werte bis 60°C gültig • Valores válidos hasta 60°C

FRA	60°C	E	100°C	DECLASSARE VELOCITÀ	4%
	100°C		150°C		10%
• entre • between • zwischen • entre	150°C	• et • and • und • y	200°C	• déclasser vitesse • degrade speed • Geschwindigkeit herabsetzen • rebajar velocidad	16%
	200°C		250°C		23%
	250°C		300°C		30%
	300°C		350°C		37%
	350°C		400°C		45%
	400°C		450°C		54%
	450°C		500°C		64%

■ Field of operation

Medium-low flow rates. Medium-high pressures.

Blade type

Curved radial blades, open.

Applications

For pneumatic transport of solid materials mixed with air, sawdust and wood chips; also suitable for filaments which would block a reversed blade closed fan.

Standard constructional arrangements

Arr.1 - Arr.4 - Arr.5 - Arr.8 - Arr.9 - Arr.12, see pgs. 2.5 - 2.6.

Standard fluid temperatures

-10÷+60°C. For other temperatures see pgs. 1.12 to 1.15.

Type of construction

Fan in Fe360 plate, impeller in Fe360 statically and dynamically balanced. For other materials see pgs. 1.12 to 1.15.

Operating specifications

Condition of inlet air T=20°C, 0 m above sea level and ρ=1.205 kg/m³.

Noise level

Expressed as sound power L_{wA} [dB(A)] measured in free field with ducted fan, see pgs. 1.43 to 1.49.

Orientations

No.8 RD (clockwise viewed from transmission side) and No.8 LG. Fan in bolted orientable version for sizes 400-630, with front support and so not orientable for sizes 710 and above with transmission drive, always orientable for directly coupled fans without front support. See pag. 2.7.

Special applications

See pgs. 2.20 to 2.30.

Fan start-up

During start-up the fan flow rate must be limited, calibrated for the fan's maximum electrical input.

Impeller classes

The above table refers to standard operating conditions, in heavy-duty service conditions it is advisable to contact the CORAL Customer Service to establish the most suitable type of impeller.

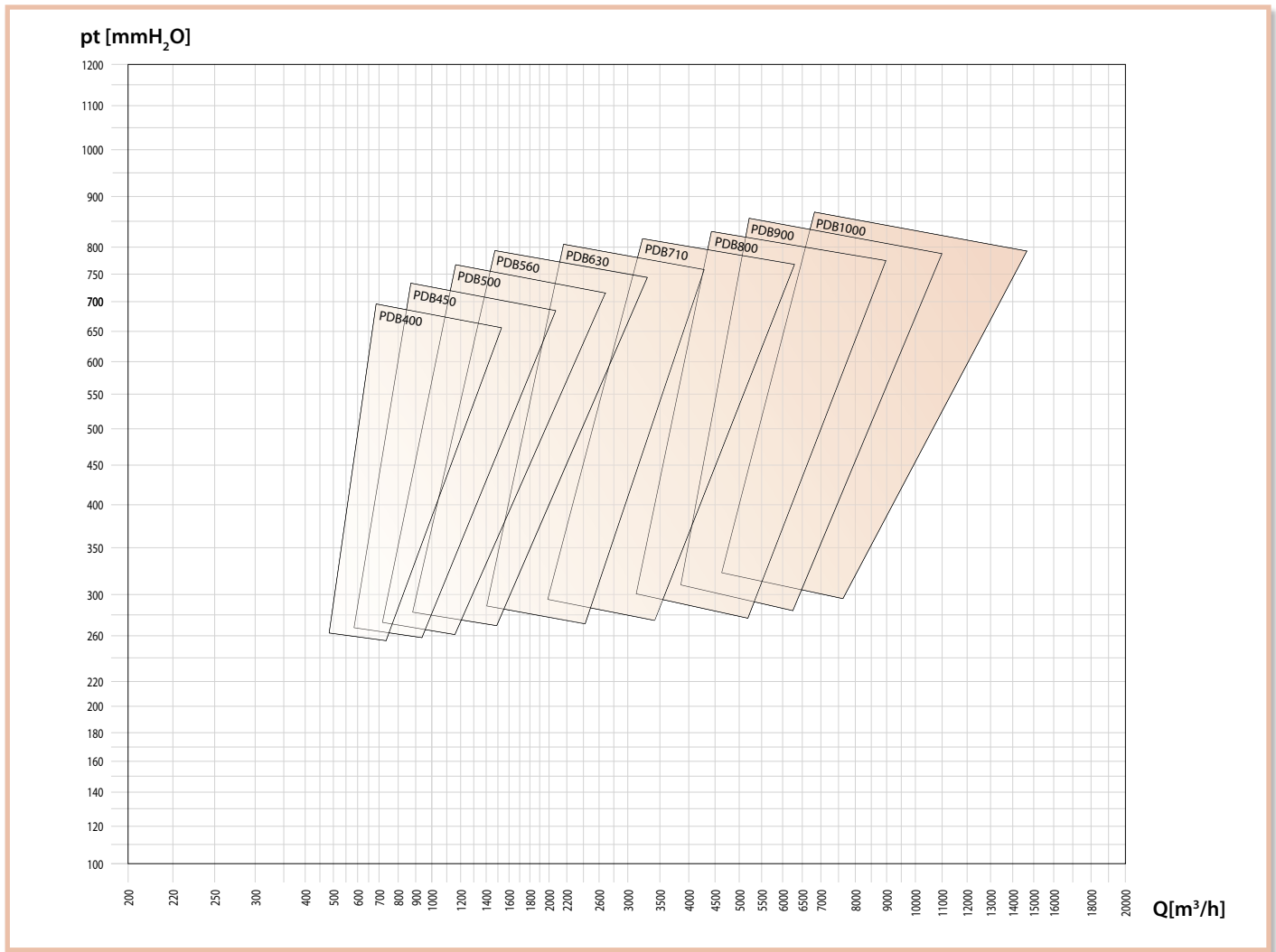

PDB

■ **Arbeitsbereich**

Mittlere - niedrige Fördermengen. Mittlere - hohe Drücke.

Schaufelform

Gekrümmte Radialschaufeln, offen.

Anwendungen

Zum Transport von in Luft vermischten Feststoffen, Sägestaub und Holzspäne, auch für fadenförmige Materialien, die einen geschlossenen Ventilator mit rückwärts gekrümmten Schaufeln zusetzen würden.

Konstruktive Standardausführungen

Ausf. 1-Ausf. 4-Ausf. 5-Ausf. 8-Ausf. 9-Ausf. 12, siehe Seiten 2.5 - 2.6.

Standardtemperatur des Mediums

-10 ÷ +60°C. Für andere Temperaturen siehe Seiten 1.12 bis 1.15.

Konstruktionsart

Ventilator aus Blech Fe360, Laufrad aus Fe360, statisch und dynamisch ausgewuchtet. Für andere Materialien siehe Seiten 1.12 bis 1.15.

Betriebsdaten

Physikalischer Zustand der Ansaugluft T = 20°C, 0 m ü. M. und ρ = 1.205 kg/m³.

Geräuschpegel

angegeben als Schalleistungspegel L_{WA} [dB(A)] mit Messung im Freifeld und an Rohren angeschlossenen Ventilatoren, siehe Seiten 1.43 bis 1.49.

Ausrichtung

8 Modelle RD (Drehrichtung im Uhrzeigersinn, von Antriebsseite aus gesehen) und 8 Modelle LG. Angeschraubter, in der Ausrichtung veränderbarer Ventilator in den Größen 400 - 630, mit Vorderstütze und damit nicht veränderbar ab Größe 710 mit Riementrieb, immer ausrichtbar bei allen direkt angetriebenen Ventilatoren ohne Vorderstütze, siehe Seite 2.7.

Spezialausführungen

Siehe Seiten 2.20 bis 2.30.

Ventilator-Anlauf

Der Ventilatoranlauf muss bei teilweise geschlossenem Ventilator erfolgen, in Abhängigkeit von der maximalen Stromaufnahme des Motors.

Laufradklassen

Die obestehende Tabelle bezieht sich auf normale Betriebsbedingungen. Bei erschwerenden Betriebsbedingungen wird empfohlen, den Kundenservice von CORAL zu kontaktieren, um den am besten geeigneten Laufradtyp zu bestimmen.

■ **Campo de trabajo**

Caudales medio-bajos. Presiones medio-altas.

Tipo de pala

Palas radiales curvas, abierta.

Aplicaciones

Para transporte neumático de materiales sólidos mezclados con aire, serrín y virutas de madera; también para materiales filamentosos que obstruirían un ventilador cerrado de palas invertidas.

Variantes constructivas estándares

Ejec.1-Ejec.4-Ejec.5-Ejec.8-Ejec.9-Ejec.12, ver págs. 2.5 - 2.6.

Temperaturas del fluido estándares

De -10 a +60°C. Para otras temperaturas, ver págs. de 1.12 a 1.15.

Tipo de construcción

Ventilador de chapa en Fe360, rotor en Fe360 equilibrado estática y dinámicamente. Para otros materiales, ver págs. de 1.12 a 1.15.

Datos de funcionamiento

Condiciones del aire en aspiración T=20°C, 0 m SNM y ρ=1.205 kg/m³.

Niveles de ruido

Expresados en potencia sonora L_{WA} [dB(A)] medida en campo abierto con ventilador canalizado, ver págs. de 1.43 a 1.49.

Orientaciones

8 RD (rotación dextrógira vista desde el lado de transmisión) y 8 LG. Ventilador en versión empernada orientable para tamaños 400-630, con soporte delantero, por lo cual no es orientable a partir del tamaño 710 de transmisión, siempre orientable en ventiladores acoplados directamente sin soporte delantero. Ver pág. 2.7.

Construcciones especiales

Ver págs. de 2.20 a 2.30.

Puesta en marcha del ventilador

La puesta en marcha debe efectuarse con ventilador parcializado, en función de la absorción máxima del ventilador.

Clases de rotores

La tabla arriba hace referencia a condiciones de trabajo estándares, en condiciones de funcionamiento pesadas se aconseja llamar al Servicio de atención al cliente de CORAL para conocer el tipo de rotor más adecuado.

Tipo • Type • Type • Typ • Tipo		P inst. [kW]	n	LpA [dB(A)]	Tolleranza sulla portata ±5% • Tolérance sur le débit ±5% • Load tolerance ±5% • Durchsatztoleranz ±5% • Tolerancia respecto caudal ±5%									
Ventilatore • Ventilateur • Fan • Ventilator • Ventilador	Motore • Moteur • Motor • Motor • Motor				Q [m³/h]									
					430	470	540	650	720	790	865	935	1080	1225
		pt[mmH ₂ O]												
PDB400/P2	90	2,2	2900	70	290	290	290	285	285	285	285	285	284	280
PDB450/P2	100	3	2920	72				372	372	370	370	368	368	367
PDB450/P2	112	4	2920	74				372	372	370	370	368	368	367
PDB500/P2	132	5,5	2920	76								460	459	458
PDB500/P2	132	7,5	2960	78								470	469	468
PDB560/P2	132	7,5	2960	78										
PDB560/P2	160	11	2960	80										
PDB630/P2	160	15	2960	80										
PDB630/P2	160	18,5	2960	82										
PDB710/P2R	180	22	2960	82										
PDB710/P2	200	30	2960	83										
PDB710/P2	200	37	2960	85										
PDB800/P2R	200	37	2960	86										
PDB800/P2	225	45	2960	87										
PDB800/P2	250	55	2970	88										
PDB800/P4R	132	7,5	1470	74										
PDB800/P4	160	11	1480	75										
PDB900/P4R	160	11	1480	75										
PDB900/P4	160	15	1480	77										
PDB1000/P4R	180	18,5	1480	78										
PDB1000/P4	180	22	1480	79										

PDB
CARATTERISTICHE IN ASPIRAZIONE

Tipo • Type • Type • Typ • Tipo		P inst. [kW]	n	LpA [dB(A)]	Tolleranza sulla portata ±5% • Tolérance sur le débit ±5% • Load tolerance ±5% • Durchsatztoleranz ±5% • Tolerancia respecto caudal ±5%									
Ventilatore • Ventilateur • Fan • Ventilator • Ventilador	Motore • Moteur • Motor • Motor • Motor				Q [m³/h]									
					430	470	540	650	720	790	865	935	1080	1225
		pt[mmH ₂ O]												
PDB400/P2	90	2,2	2900	70	281	281	281	275	275	274	273	273	270	264
PDB450/P2	100	3	2920	72				358	357	355	355	353	352	350
PDB450/P2	112	4	2920	74				358	357	355	355	353	352	350
PDB500/P2	132	5,5	2920	76								439	437	436
PDB500/P2	132	7,5	2960	78								448	447	445
PDB560/P2	132	7,5	2960	78										
PDB560/P2	160	11	2960	80										
PDB630/P2	160	15	2960	80										
PDB630/P2	160	18,5	2960	82										
PDB710/P2R	180	22	2960	82										
PDB710/P2	200	30	2960	83										
PDB710/P2	200	37	2960	85										
PDB800/P2R	200	37	2960	86										
PDB800/P2	225	45	2960	87										
PDB800/P2	250	55	2970	88										
PDB800/P4R	132	7,5	1470	74										
PDB800/P4	160	11	1480	75										
PDB900/P4R	160	11	1480	75										
PDB900/P4	160	15	1480	77										
PDB1000/P4R	180	18,5	1480	78										
PDB1000/P4	180	22	1480	79										

Il livello di pressione sonora ponderato A, LpA (cap.14), corrisponde al valore rilevato, nelle condizioni di prova, nel punto di massima rumorosità.

CARATTERISTICHE IN MANDATA

■ CARACTERISTIQUES EN SOUFFLAGE ■ DELIVERY CHARACTERISTICS ■ LEISTUNGSMERKMALE ■ CARACTERISTICAS EN EMPUJE



Tolleranza sulla rumorosità ±4dB(A)																	
• Tolérance sur le bruit ±4dB(A) • Noise tolerance ±4dB(A)																	
• Geräushtoleranz ±4dB(A) • Tolerancia respecto a ruido ±4dB(A)																	
Q [m³/h]																	
1370	1440	1620	1800	2160	2520	2880	3240	3600	3960	4320	4680	5400	6120	7200	7920	9000	10600
pt[mmH ₂ O]																	
276																	
367	367	362															
367	367	362	357	352													
457	455	453	451	448	442												
467	465	463	461	458	452	438	407										
594	593	592	590	588	585	581											
594	593	592	590	588	585	581	577	568	561								
	765	767	768	769	772	774	775	775	773	766							
	765	767	768	769	772	774	775	775	773	766	757	752					
					870	869	868	868	868	867	866	865	852				
					980	984	986	988	989	989	988	987	986	970			
					980	984	986	988	989	989	988	987	986	970	940		
								1143	1144	1145	1146	1147	1148	1147			
									1233	1233	1233	1236	1238	1239	1239		
									1241	1241	1241	1244	1246	1247	1247	1233	1213
			283	283	283	282	282	282	281	279	276	270	258				
			305	305	305	305	304	304	304	304	304	298	290				
					369	369	369	368	368	368	367	365	362	355			
						395	395	395	395	394	394	392	390	385	380		
								449	449	449	448	448	448	445	443	436	
									486	486	486	486	486	484	482	481	470

PDB

CARATTERISTICHE IN ASPIRAZIONE

■ CARACTERISTIQUES EN FAIT D'ASPIRATION ■ SUCTION CHARACTERISTICS ■ ANSAUGEIGENSCHAFTEN ■ CARACTERISTICAS EN ASPIRACION

Tolleranza sulla rumorosità ±4dB(A)																	
• Tolérance sur le bruit ±4dB(A) • Noise tolerance ±4dB(A)																	
• Geräushtoleranz ±4dB(A) • Tolerancia respecto a ruido ±4dB(A)																	
Q [m³/h]																	
1370	1440	1620	1800	2160	2520	2880	3240	3600	3960	4320	4680	5400	6120	7200	7920	9000	10600
pt[mmH ₂ O]																	
259																	
348	348	341															
348	348	341	335	325													
434	432	429	426	421	412												
443	441	438	435	430	421	405	372										
560	559	557	555	551	547	541											
560	559	557	555	551	547	541	535	524	515								
	711	712	713	713	714	715	714	713	709	701							
	711	712	713	713	714	715	714	713	709	701	691	682					
					800	798	796	795	794	792	790	785	771				
					893	895	896	896	896	895	893	889	885	865			
					893	895	896	896	896	895	893	889	885	865	835		
								1026	1026	1026	1026	1025	1024	1019			
								1098	1097	1096	1097	1096	1094	1091			
								1104	1103	1103	1103	1103	1100	1097	1082	1057	
			274	274	273	271	271	270	268	265	261	252	237				
			295	295	294	293	291	290	289	288	287	279	268				
					355	354	354	352	352	351	349	346	341	331			
						379	378	377	377	375	374	371	367	359	352		
								428	428	428	426	425	424	419	416	407	
									462	462	461	460	459	455	452	448	433

■ Le niveau de pression sonore pondérée A, LpA (chap. 14), correspond à la valeur relevée dans les conditions d'essai au point de niveau sonore maximum.

■ Der nach A bewertete Schalldruckpegel LpA (Kap. 14) entspricht in den Testbedingungen dem höchsten gemessenen Wert des Geräuschpegels.

■ The A-weighted sound power level, LpA (Chap.14), is the value measured in test conditions at the point of maximum noise level.

■ El nivel de presión sonora ponderado A, LpA (cap. 14), corresponde al valor medido, en las condiciones de prueba, en el punto con máximos niveles de ruido.

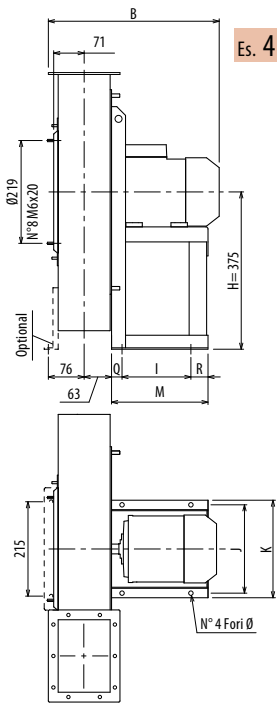

Es. 4

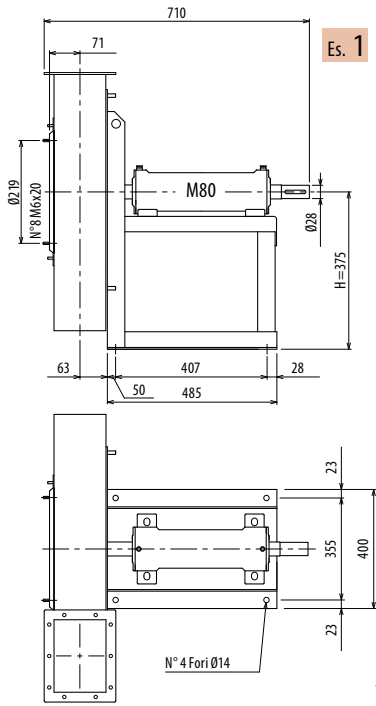

Es. 1

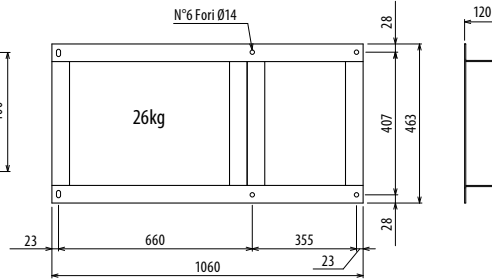
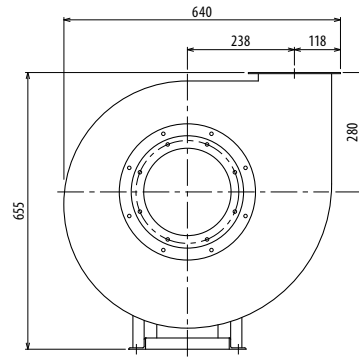

Il ventilatore è orientabile • Peso in tabella comprensivo di motore

- Le ventilateur est orientable
 - The fan is revolvable
 - Der Ventilator ist drehbar
 - El ventilador es orientable
- Le poids dans le tableau inclut le moteur The weight indicated in the table includes motor Gewichtsangabe in Tabelle inkl. Motor El peso en la tabla incluye el motor

Ulteriori informazioni e quote:
■ Ulteriori informazioni e cotes:
■ Further information and sizes:
■ Weitere Infos und Größen:
■ Más informaciones y medidas:

TIPO - Type		PESO Weight	PD ²											
VENTILATORE Fan	MOTORE Motor	Kg	Kgf x m ²	B	I	H	H1	H2	J	K	M	Q	R	Ø
PDB400/P2	90 L2	60	0,60	437	133	375	280	375	234	260	246	55	58	10
PDB400/P/T		68	0,60			375	280	375						

pg. / S. 4,6
pg. / S. 4,5

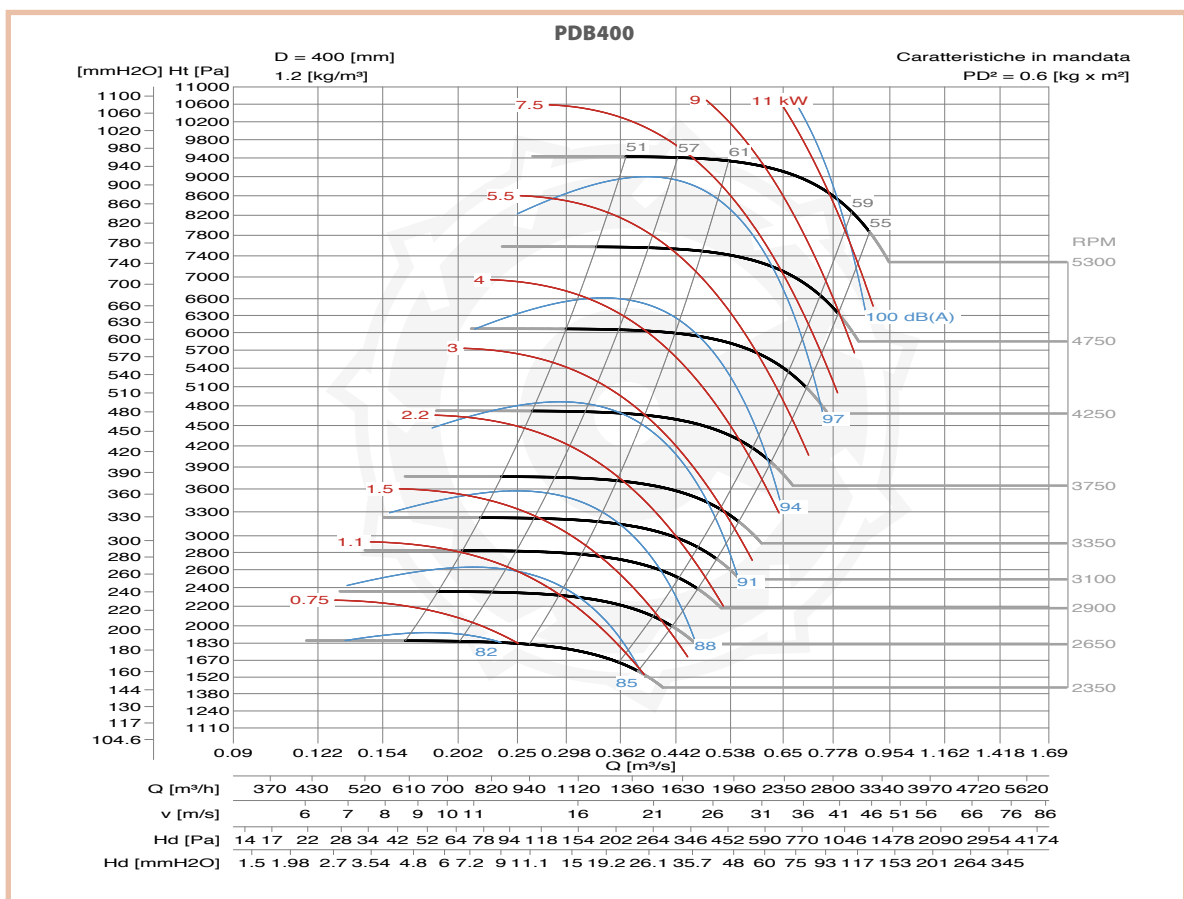
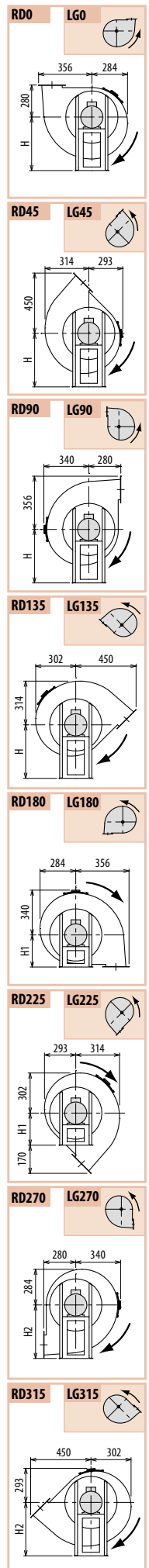
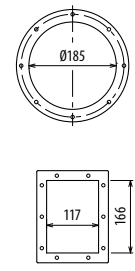

DIMENSIONI D'INGOMBRO E PESI/CURVE DI FUNZIONAMENTO

■ DIMENSIONS D'ENCOMBREMENT ET POIDS/COURBES DE FONCTIONNEMENT ■ OVERALL DIMENSIONS AND WEIGHT/WORKING CURVES
 ■ AUSMAßE UND GEWICHTE/FUNKTIONSKURVEN ■ DIMENSIONES QUE OCUPA Y PESOS/CURVAS DE FUNCIONAMIENTO

PDB450/P

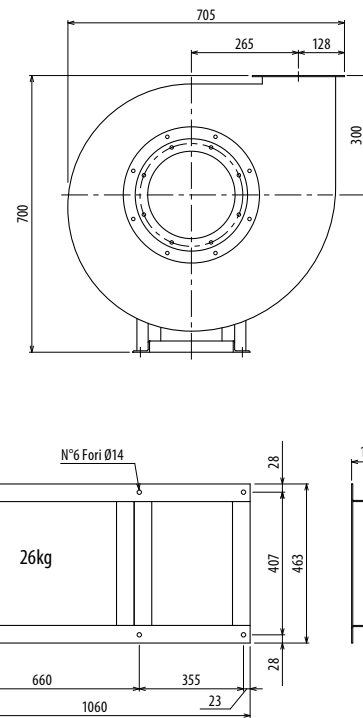
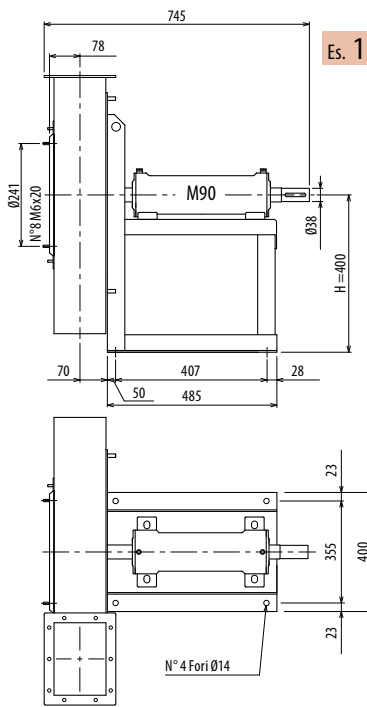
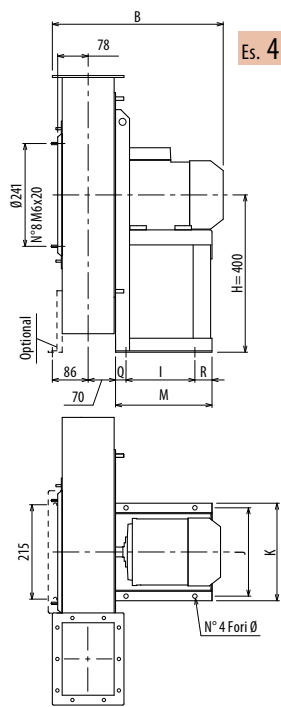

Il ventilatore è orientabile - Peso in tabella comprensivo di motore

- Le ventilateur est orientable
 - The fan is revolvable
 - Der Ventilator ist drehbar
 - El ventilador es orientable
- Le poids dans le tableau inclut le moteur The weight indicated in the table includes motor Gewichtangaben in Tabelle inkl. Motor El peso en la tabla incluye el motor

Ulteriori informazioni e quote:
 ■ Ulérieures informations et cotes:
 ■ Further information and sizes:
 ■ Weitere Infos und Größen:
 ■ Más informaciones y medidas:

TIPO - Type		PESO Weight	PD ²	B	I	H	H1	H2	J	K	M	Q	R	Ø
VENTILATORE Fan	MOTORE Motor	Kg	Kg x m ²											
PDB450/P2	100 L2	70	0,98	482	197	400	300	400	289	324	276	30	49	12
PDB450/P2	112 M2	78	0,98	503	197	400	300	400	289	324	276	30	49	12
PDB450/P/T		75	0,98			400	300	400						

pg. / S. 4,6
 pg. / S. 4,5

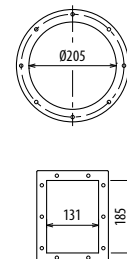

RD0 LG0

RD45 LG45

RD90 LG90

RD135 LG135

RD180 LG180

RD225 LG225

RD270 LG270

RD315 LG315

PDB

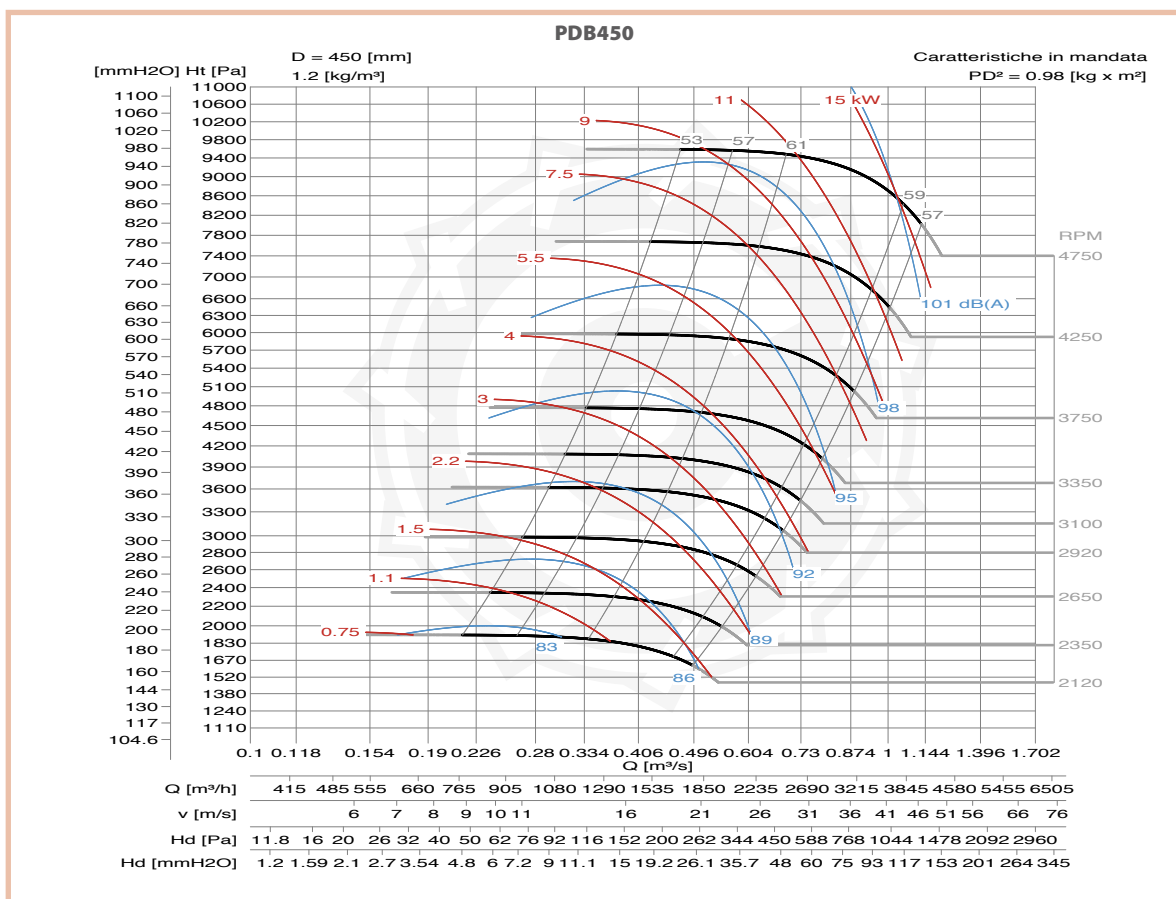

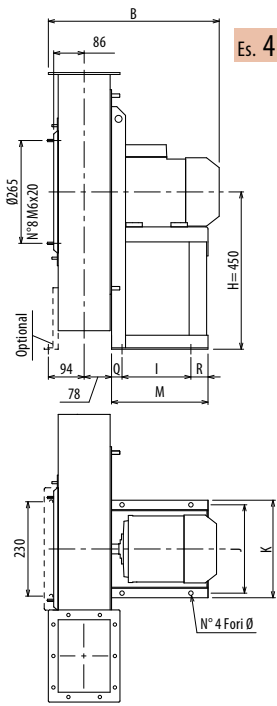

Es. 4

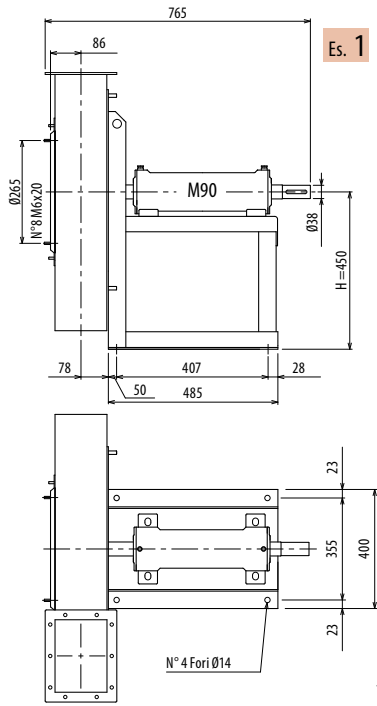

Es. 1

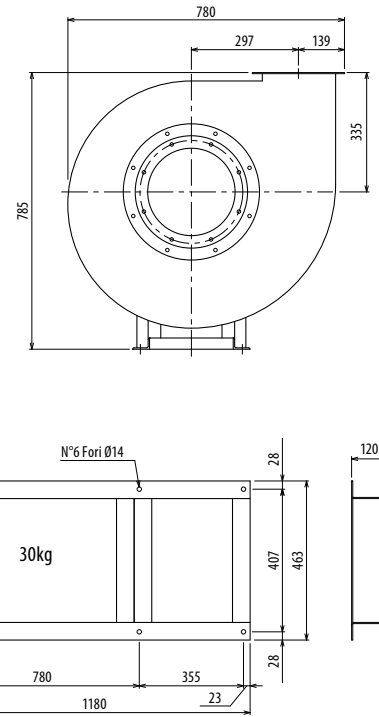

Il ventilatore è orientabile - Peso in tabella comprensivo di motore

- Le ventilateur est orientable
 - The fan is revolvable
 - Der Ventilator ist drehbar
 - El ventilador es orientable
- Le poids dans le tableau inclut le moteur The weight indicated in the table includes motor Gewichtangaben in Tabelle inkl. Motor El peso en la tabla incluye el motor

Ulteriori informazioni e quote:
■ Ulteriori informazioni e cotes:
■ Further information and sizes:
■ Weitere Infos und Größen:
■ Más informaciones y medidas:

TIPO - Type		PESO Weight	PD ²											
VENTILATORE Fan	MOTORE Motor	Kg	Kgf x m ²	B	I	H	H1	H2	J	K	M	Q	R	Ø
PDB500/P2	132 SA2	106	1,6	560	237	450	335	450	337	372	336	40	59	12
PDB500/P2	132 SB2	107	1,6	560	237	450	335	450	337	372	336	40	59	12
PDB500/P/T		90	1,6			450	335	450						

pg. / S. 4,6
pg. / S. 4,5

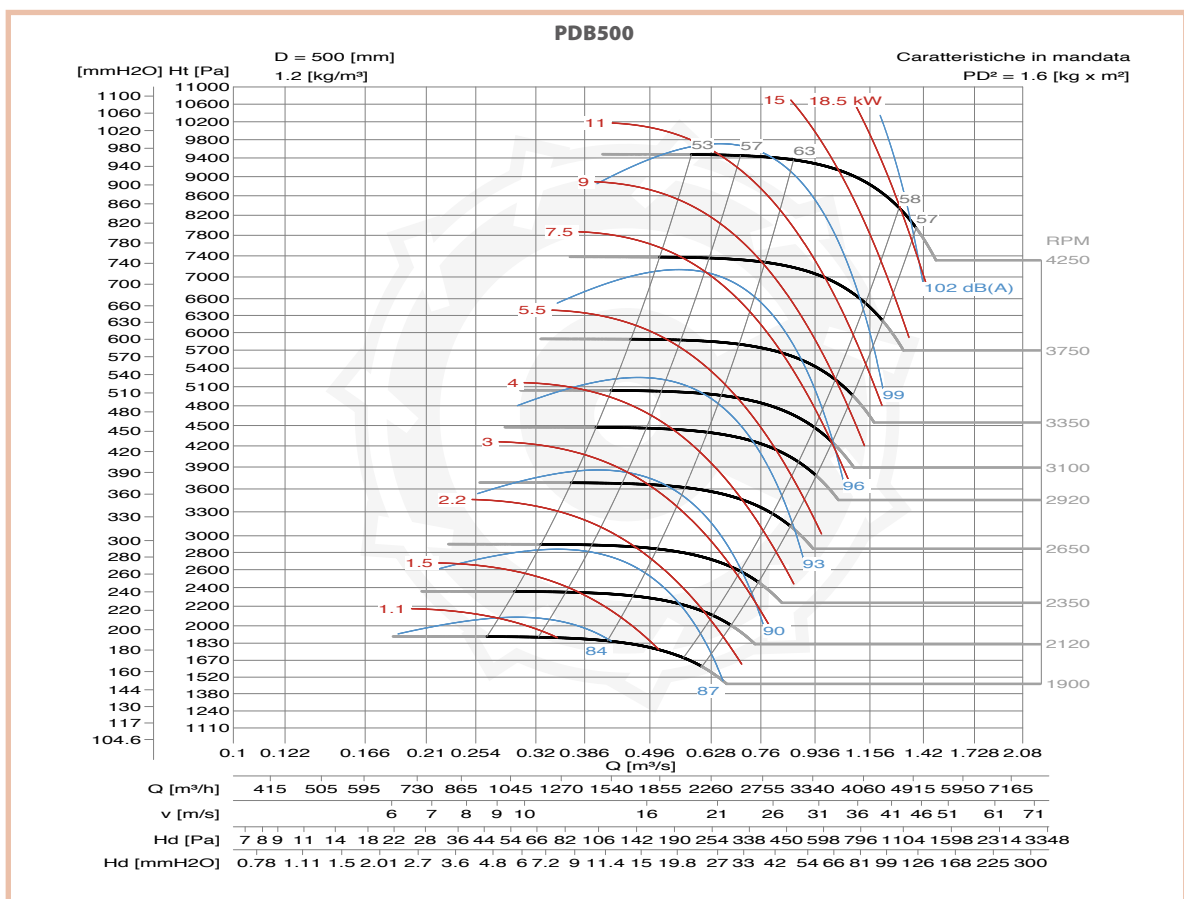
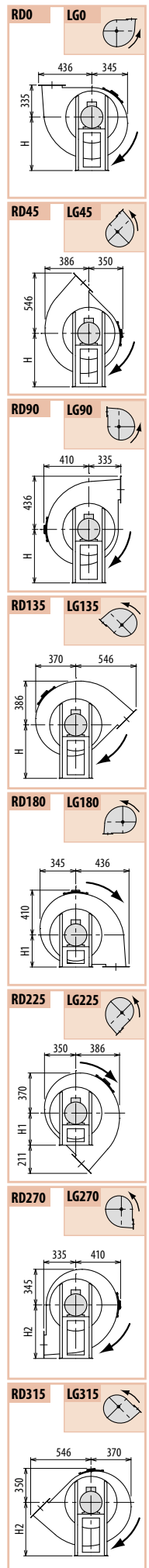
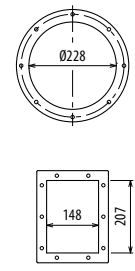

DIMENSIONI D'INGOMBRO E PESI/CURVE DI FUNZIONAMENTO

■ DIMENSIONS D'ENCOMBREMENT ET POIDS/COURBES DE FONCTIONNEMENT ■ OVERALL DIMENSIONS AND WEIGHT/WORKING CURVES
 ■ AUSMAßE UND GEWICHTE/FUNKTIONSKURVEN ■ DIMENSIONES QUE OCUPA Y PESOS/CURVAS DE FUNCIONAMIENTO

PDB560/P

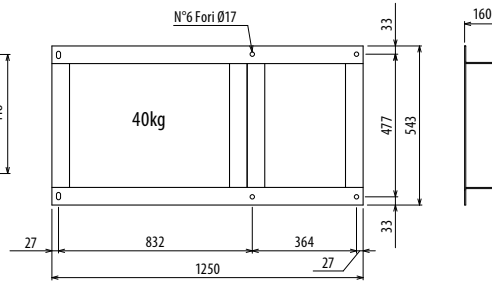
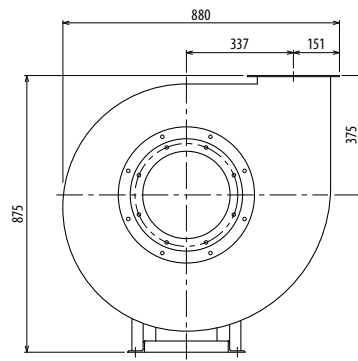
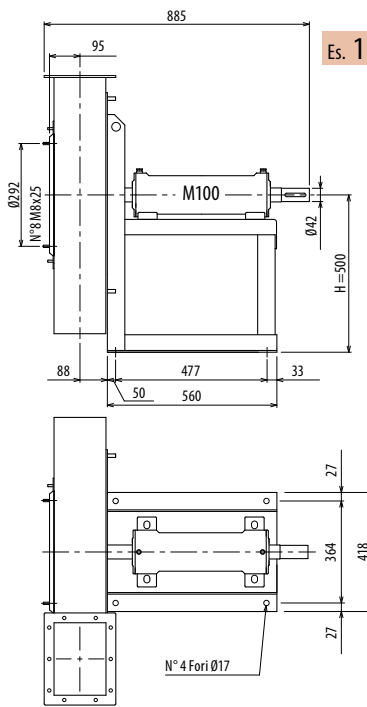
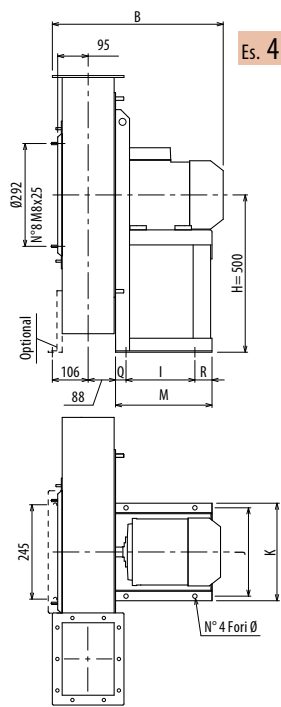

Il ventilatore è orientabile - Peso in tabella comprensivo di motore

- Le ventilateur est orientable
 - The fan is revolvable
 - Der Ventilator ist drehbar
 - El ventilador es orientable
- Le poids dans le tableau inclut le moteur The weight indicated in the table includes motor Gewichtsgabe in Tabelle inkl. Motor El peso en la tabla incluye el motor

Ulteriori informazioni e quote:
 ■ Ulérieures informations et cotes:
 ■ Further information and sizes:
 ■ Weitere Infos und Größen:
 ■ Más informaciones y medidas:

TIPO - Type		PESO Weight	PD ²	B	I	H	H1	H2	J	K	M	Q	R	Ø
VENTILATORE Fan	MOTORE Motor	Kg	Kgf x m ²											
PDB560/P2	132 SB2	130	2,6	579	237	500	375	500	337	372	336	40	59	12
PDB560/P2	160 MA2	164	2,6	684	337	500	375	500	395	440	436	50	49	14
PDB560/P/T		115	2,6			500	375	500						

pg. / S. 4,6

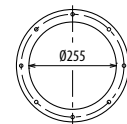

pg. / S. 4,5

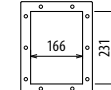

RD0 LG0

RD45 LG45

RD90 LG90

RD135 LG135

RD180 LG180

RD225 LG225

RD270 LG270

RD315 LG315

PDB

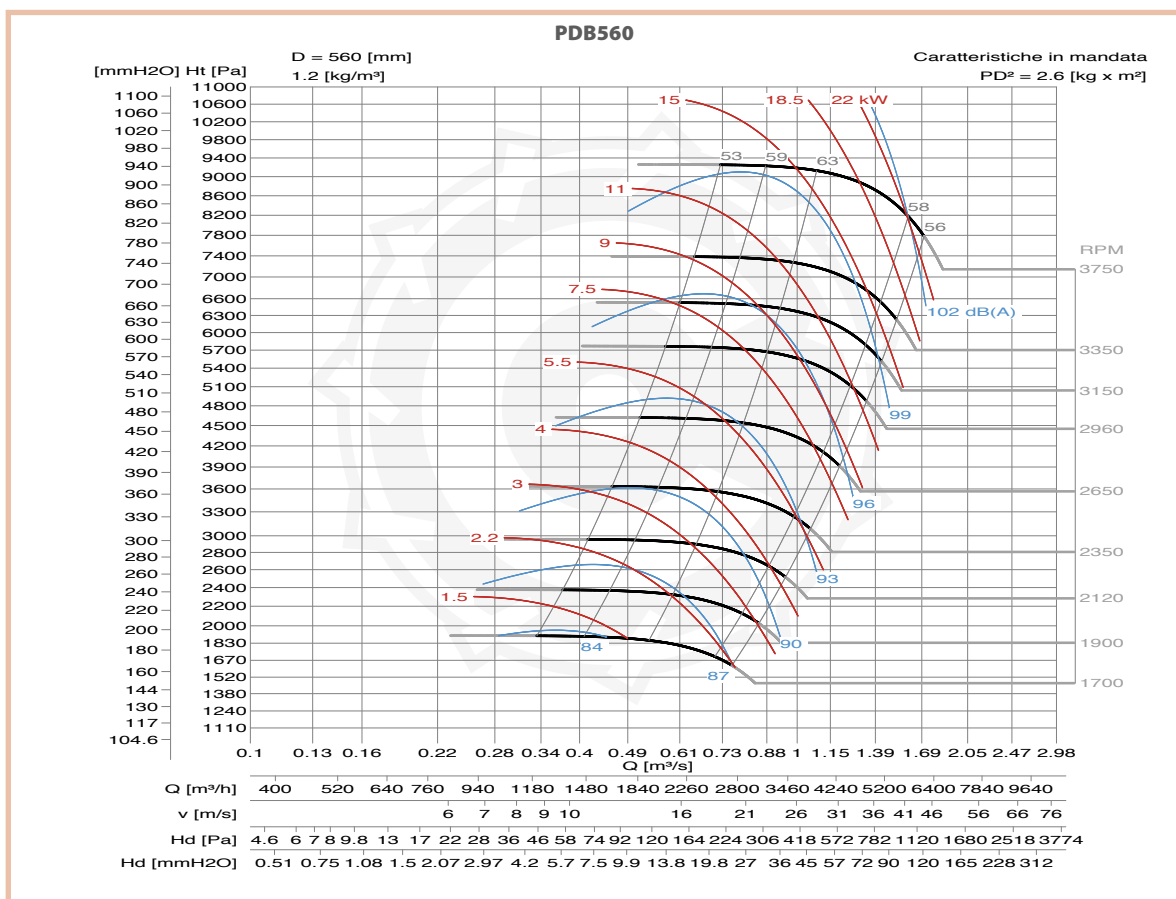

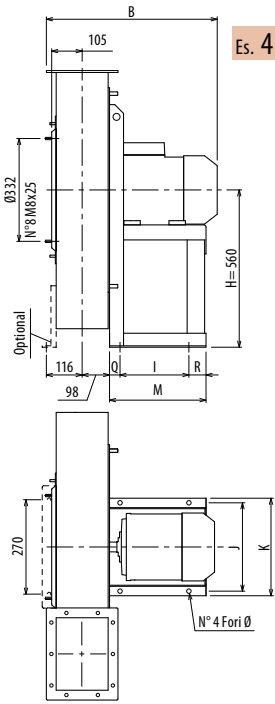

Es. 4

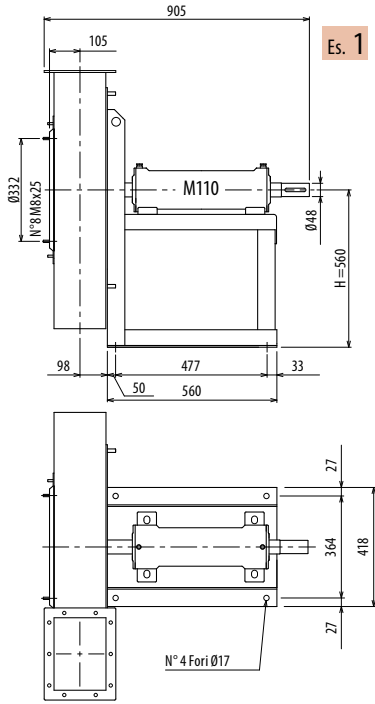

Es. 1

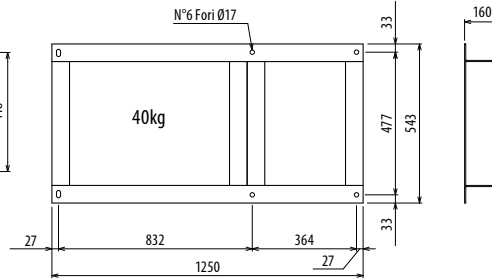
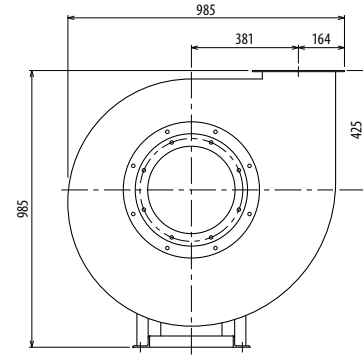

Il ventilatore è orientabile • Peso in tabella comprensivo di motore

- Le ventilateur est orientable
 - The fan is revolvable
 - Der Ventilator ist drehbar
 - El ventilador es orientable
- Le poids dans le tableau inclut le moteur The weight indicated in the table includes motor Gewichtsaangabe in Tabelle inkl. Motor El peso en la tabla incluye el motor

Ulteriori informazioni e quote:
 ■ Ulérieures informations et cotes:
 ■ Further information and sizes:
 ■ Weitere Infos und Größen:
 ■ Más informaciones y medidas:

TIPO - Type		PESO Weight	PD ²											
VENTILATORE Fan	MOTORE Motor	Kg	Kgf x m ²	B	I	H	H1	H2	J	K	M	Q	R	Ø
PDB630/P2	160 MB2	182	4,7	703	337	560	425	560	395	440	436	50	49	14
PDB630/P2	160 L2	194	4,7	703	337	560	425	560	395	440	436	50	49	14
PDB630/P/T		167	4,7			560	425	560						

pg. / S. 4,6
pg. / S. 4,5

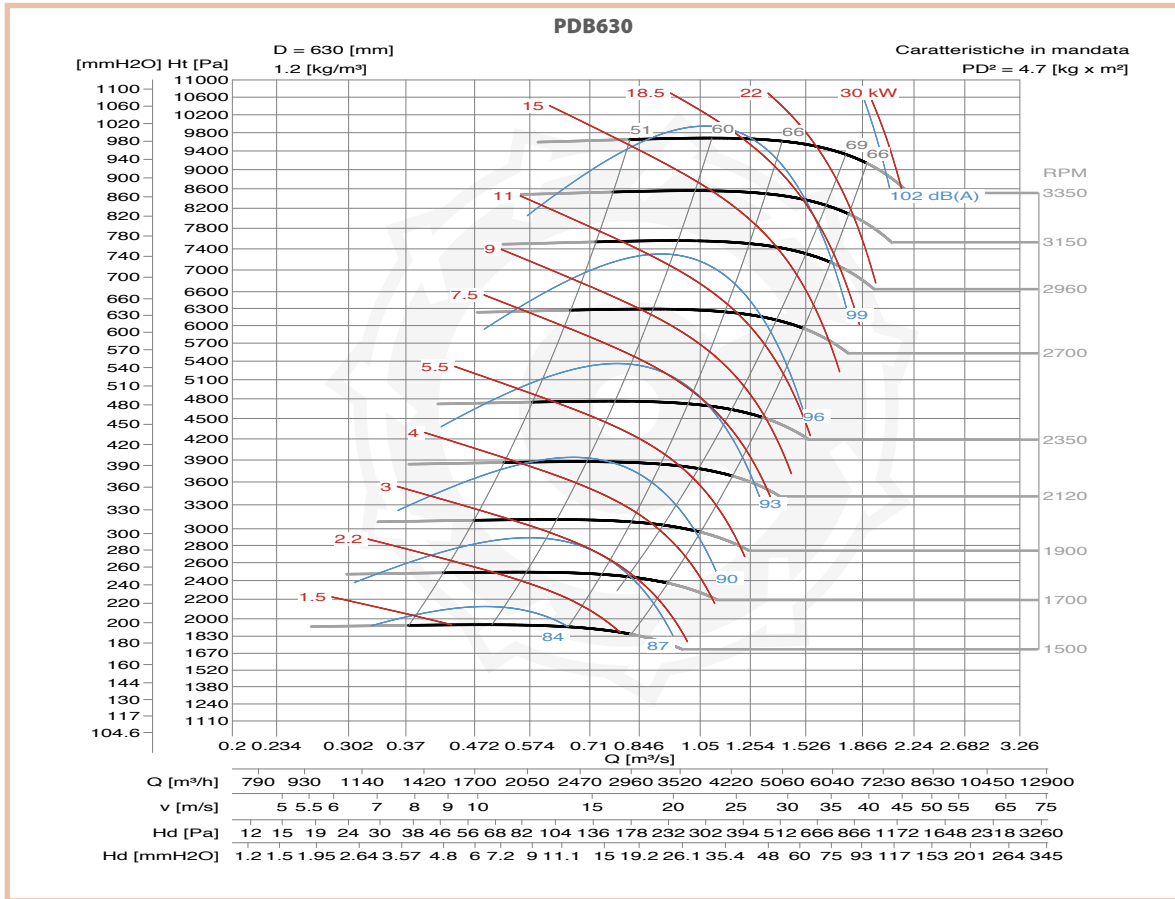
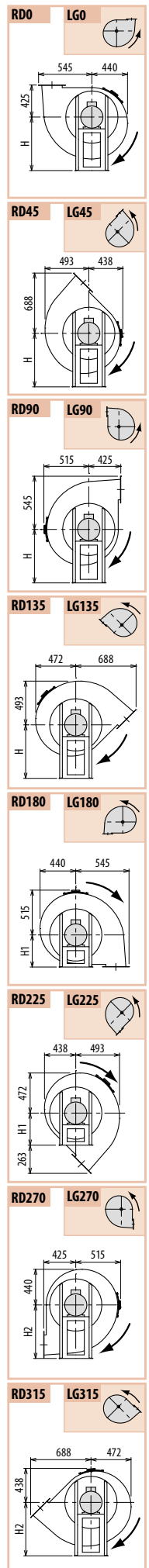
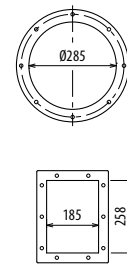

DIMENSIONI D'INGOMBRO E PESI/CURVE DI FUNZIONAMENTO

■ DIMENSIONS D'ENCOMBREMENT ET POIDS/COURBES DE FONCTIONNEMENT ■ OVERALL DIMENSIONS AND WEIGHT/WORKING CURVES
 ■ AUSMAßE UND GEWICHTE/FUNKTIONSKURVEN ■ DIMENSIONES QUE OCUPA Y PESOS/CURVAS DE FUNCIONAMIENTO

PDB710/P

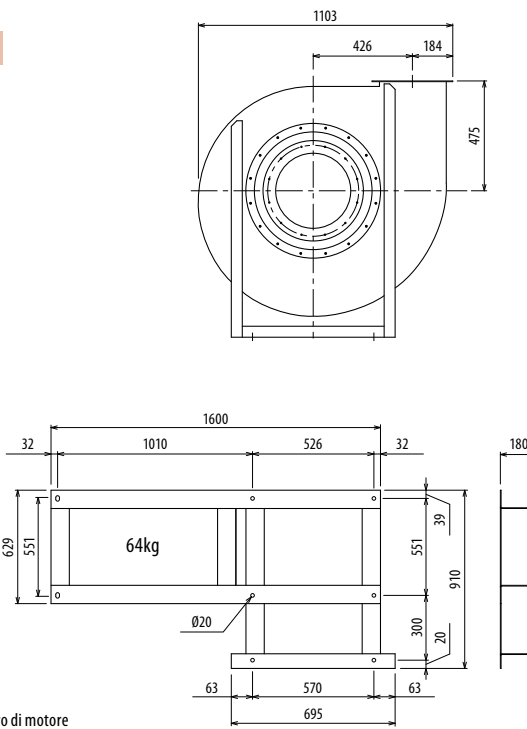
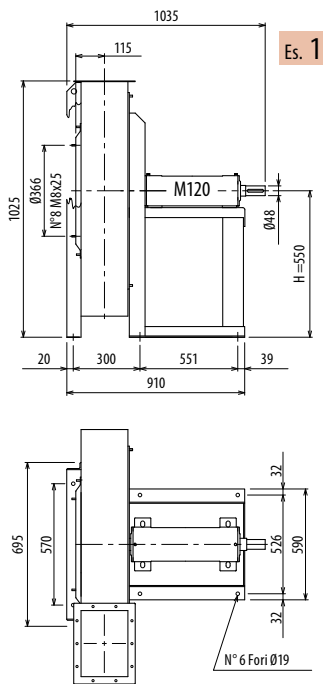
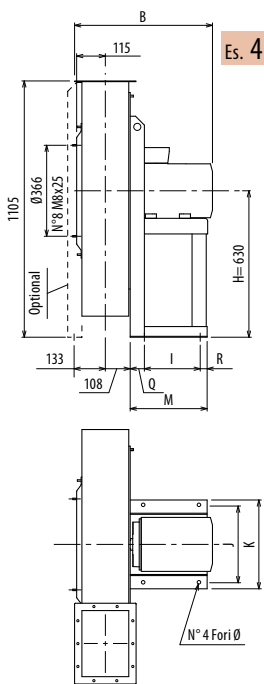

Il ventilatore in ES. 4 senza supporto anteriore è orientabile, in ES. 1 non è orientabile • Peso in tabella comprensivo di motore

- Le ventilateur en Ex. 4 sans support frontal est orientable, en Ex. 1 n'est pas orientable. ■ The fan in Ex. 4 without front support is revoluble, in Ex. 1 is not revoluble. ■ Utérieures informations et cotes: Further information and sizes: Weitere Infos und Größen: Más informaciones y medidas:
 - Der Ventilator in Aus. 4, ohne Vorderhalterung, ist drehbar; in Aus. 1 ist nicht drehbar. ■ El ventilador en Ej. 4 sin soporte delantero es orientable, en Ej. 1 no es orientable.

TIPO - Type		PESO Weight	PD ²											
VENTILATORE Fan	MOTORE Motor	Kg	Kgf x m ²	B	I	H	H1	H2	J	K	M	Q	R	Ø
PDB710/P2R	180 M2	311	7,5	809	357	630	475	630	434	488	460	70	33	17
PDB710/P2	200 LA2	445	7,5	917	381	630	475	630	506	568	500	80	39	19
PDB710/P2	200 LB2	447	7,5	917	381	630	475	630	506	568	500	80	39	19
PDB710/P/T		258	7,5			550	475	630						

pg./S. 4,6
pg./S. 4,5

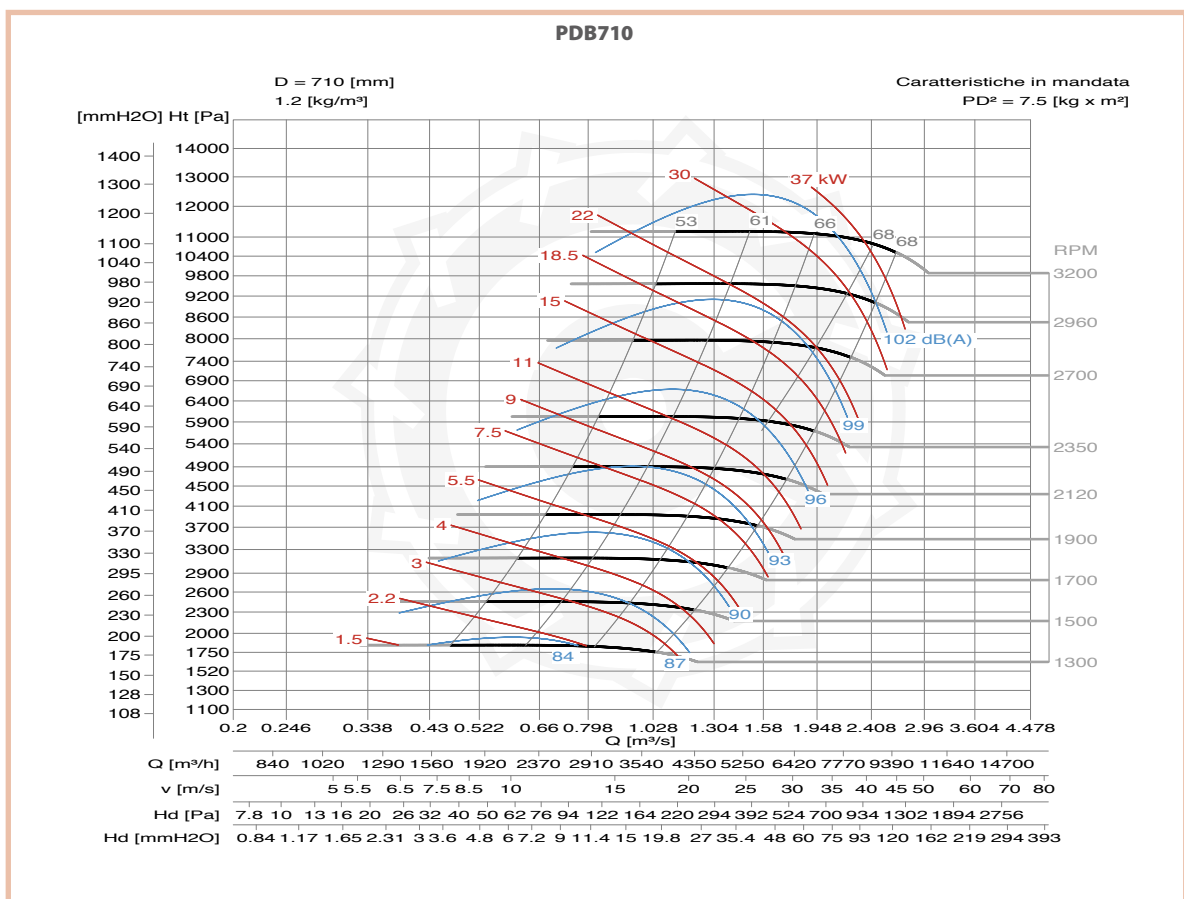
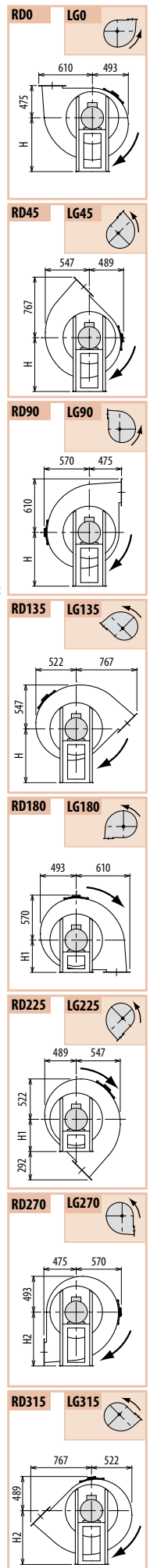
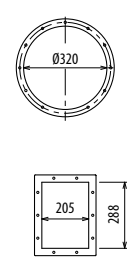

PDB

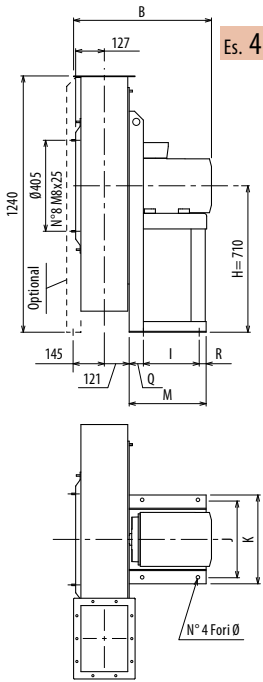

Es. 4

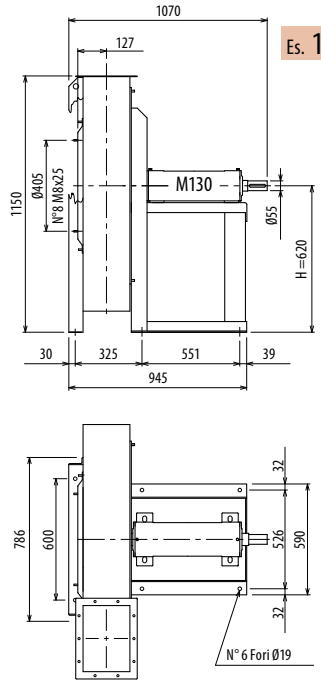

Es. 1

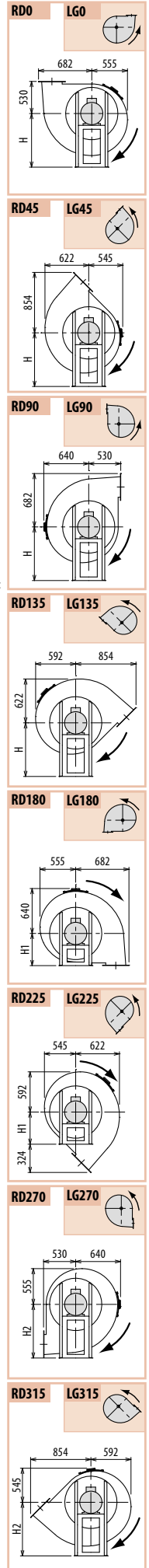
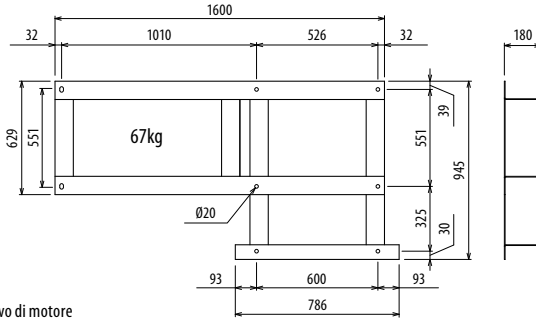
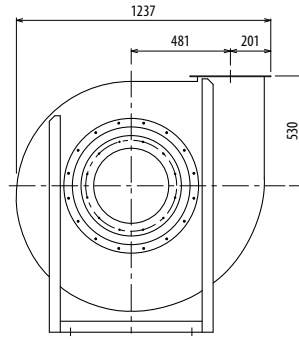

Il ventilatore in Es. 4 senza supporto anteriore è orientabile, in Es. 1 non è orientabile • Peso in tabella comprensivo di motore

- Le ventilateur en Ex. 4 sans support frontal est orientable, en Ex. 1 n'est pas orientable. ■ The fan in Ex. 4 without front support is revolvable, in Ex. 1 is not revolvable.
- Der Ventilator in Aus. 4, ohne Vorderhalterung, ist drehbar; in Aus. 1 ist nicht drehbar. ■ El ventilador en Ej. 4 sin soporte delantero es orientable, en Ej. 1 no es orientable.
- Das Gewicht im Tafel schließt den Motor ein. ■ El peso en la tabla incluye el motor

Ulteriori informazioni e quote:
 ■ Ulérieures informations et cotes:
 ■ Further information and sizes:
 ■ Weitere Infos und Größen:
 ■ Más informaciones y medidas:

TIPO - Type		PESO Weight	PD ²											
VENTILATORE Fan	MOTORE Motor	Kg	Kgf x m ²	B	I	H	H1	H2	J	K	M	Q	R	Ø
PDB800/P2R	200 LB2	520	15	942	381	710	530	710	506	568	500	80	39	19
PDB800/P2	225 M2	603	17	984	421	710	530	710	556	616	540	80	39	19
PDB800/P2	250 M2	661	17	1092	501	710	530	710	604	690	600	60	39	19
PDB800/P4R	132 MA4	250	15	648	237	710	530	710	337	372	336	40	59	12
PDB800/P4	160 M4	276	17	753	337	710	530	710	395	440	436	50	49	14
PDB800/P/T		270	17			620	530	710						

pg. / s. 4,6

pg. / s. 4,5

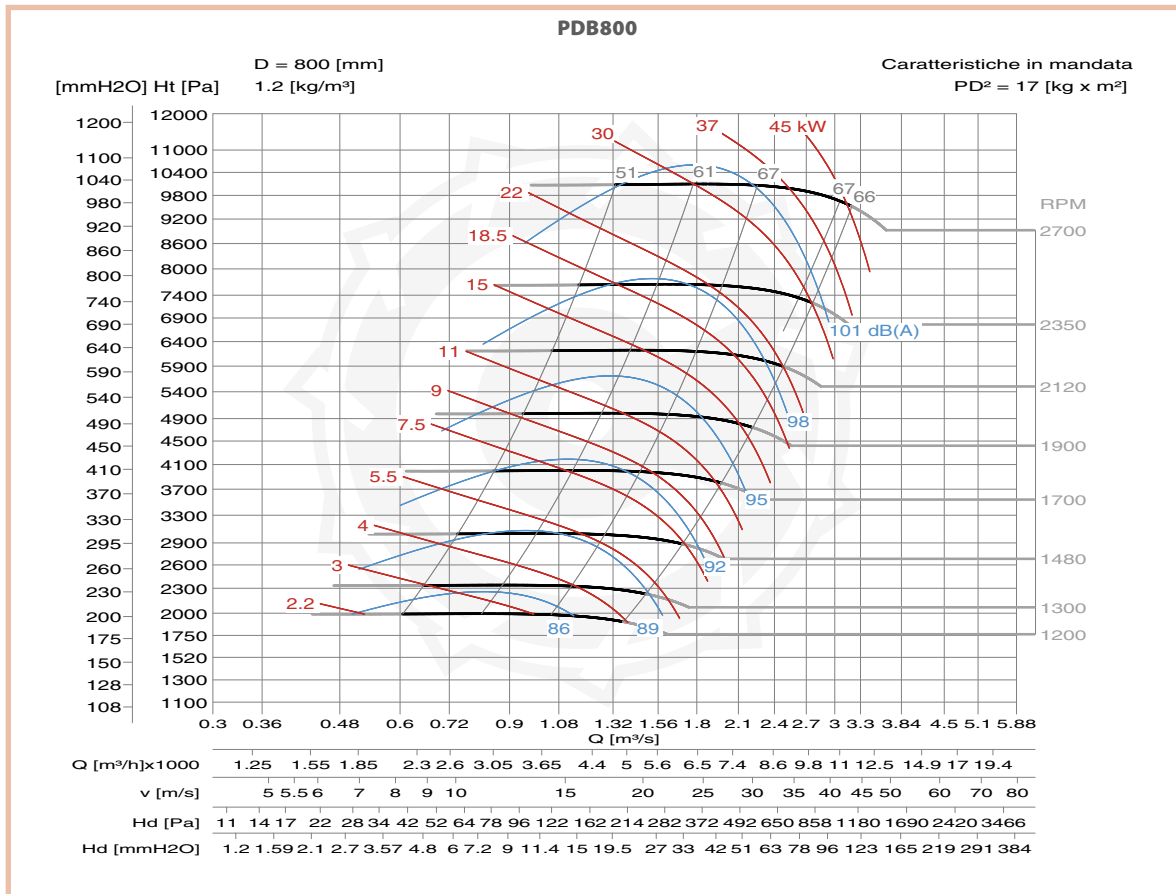
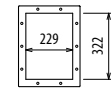

DIMENSIONI D'INGOMBRO E PESI/CURVE DI FUNZIONAMENTO

■ DIMENSIONS D'ENCOMBREMENT ET POIDS/COURBES DE FONCTIONNEMENT ■ OVERALL DIMENSIONS AND WEIGHT/WORKING CURVES
 ■ AUSMAßE UND GEWICHTE/FUNKTIONSKURVEN ■ DIMENSIONES QUE OCUPA Y PESOS/CURVAS DE FUNCIONAMIENTO

PDB900/P

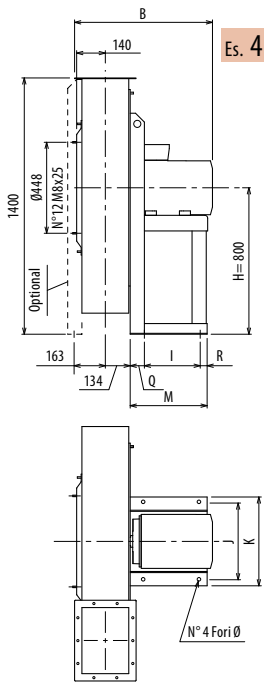

Es. 4

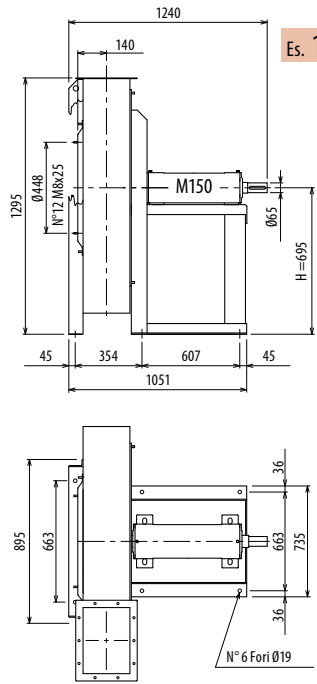

Es. 1

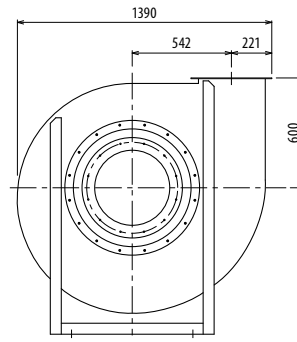

Il ventilatore in Es. 4 senza supporto anteriore è orientabile, in Es. 1 non è orientabile • Peso in tabella comprensivo di motore

■ Le ventilateur en Ex. 4 sans support frontal est orientable, en Ex. 1 n'est pas orientable.
 Le poids dans le tableau inclut le moteur
 ■ Der Ventilator in Aus. 4, ohne Vorderhalterung, ist drehbar; in Aus. 1 ist nicht drehbar.
 Das Gewicht in Tafel schließt den Motor ein

■ The fan in Ex. 4 without front support is revolvable, in Ex. 1 is not revolvable.
 The weight indicated in the table includes motor
 ■ El ventilador en Ej. 4 sin soporte delantero es orientable, en Ej. 1 no es orientable.
 El peso en la tabla incluye el motor

Ulteriori informazioni e quote:
 ■ Ulérieures informations et cotes:
 ■ Further information and sizes:
 ■ Weitere Infos und Größen:
 ■ Más informaciones y medidas:

TIPO - Type		PESO Weight	PD ²											
VENTILATORE Fan	MOTORE Motor	Kg	Kgf x m ²	B	I	H	H1	H2	J	K	M	Q	R	Ø
PDB900/P4R	160 M4	393	28	780	337	800	600	800	395	440	436	50	49	14
PDB900/P4	160 L4	406	30	780	337	800	600	800	395	440	436	50	49	14
PDB900/P/T		446	30			695	600	800						

pg./s. 4,6
 pg./s. 4,5

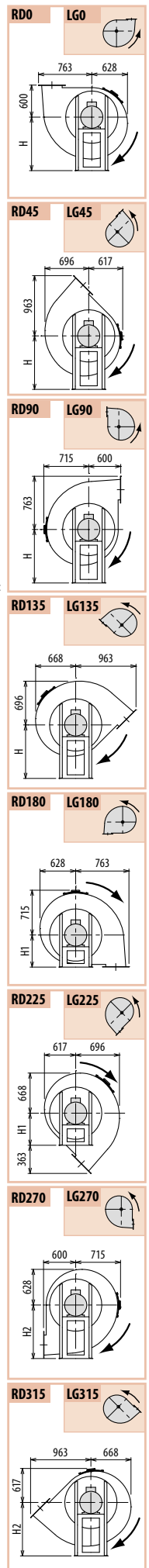
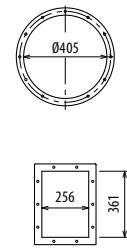

PDB

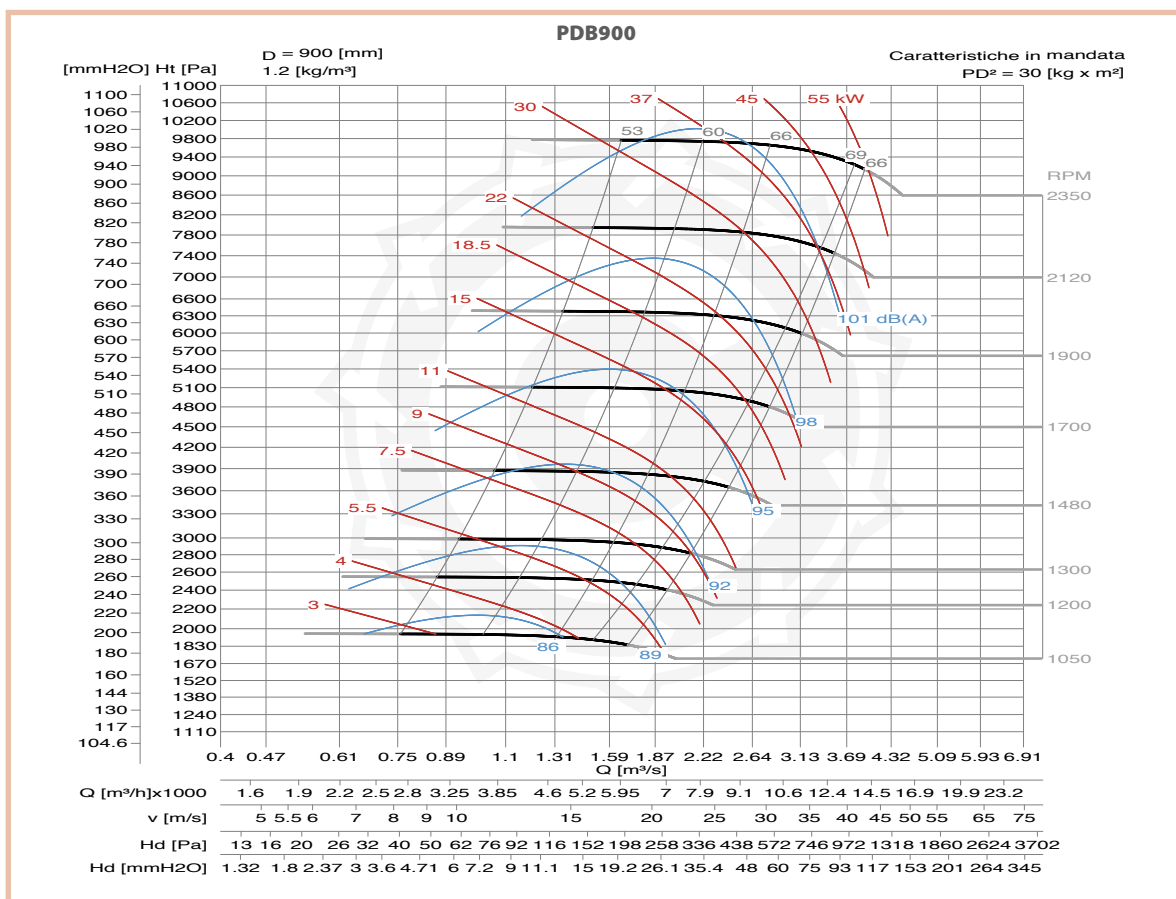

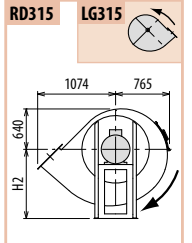
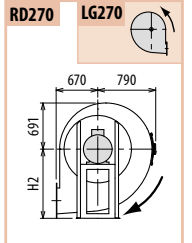
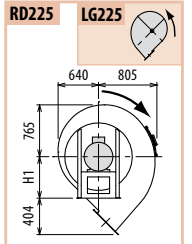
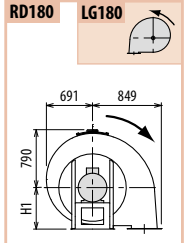
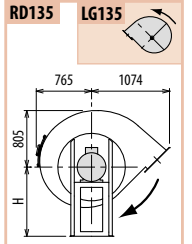
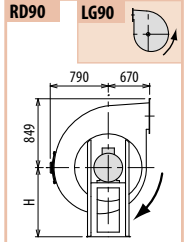
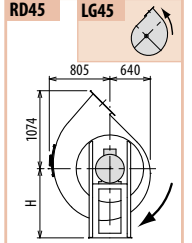
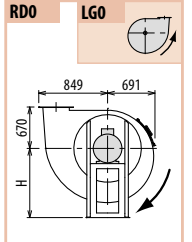
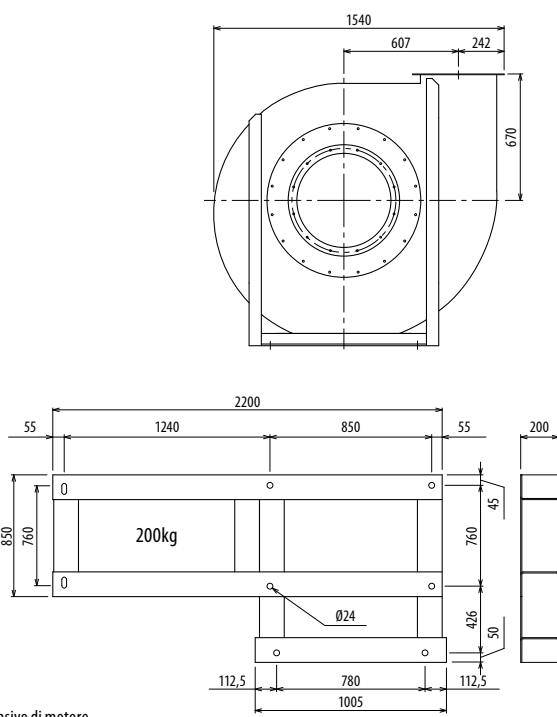
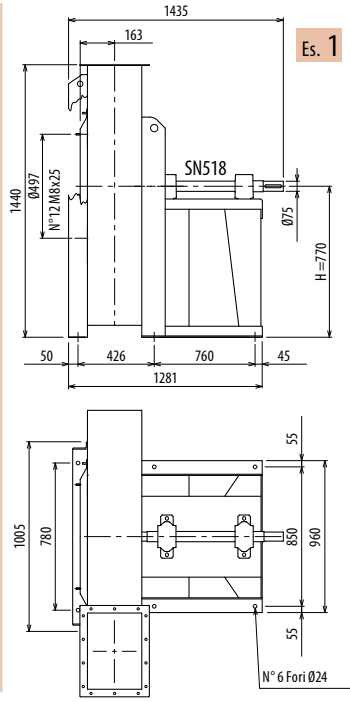
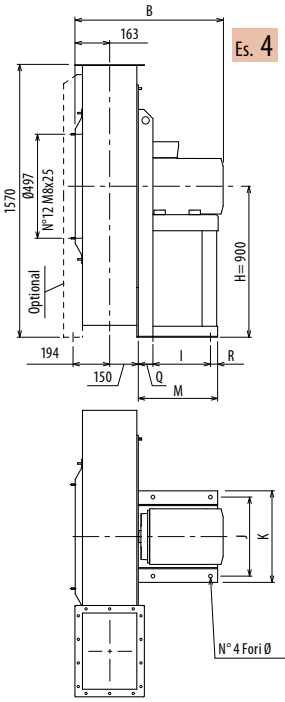

Il ventilatore in ES. 4 senza supporto anteriore è orientabile, in ES. 1 non è orientabile • Peso in tabella comprensivo di motore

■ Le ventilateur en Ex. 4 sans support frontal est orientable, en Ex. 1 n'est pas orientable.

■ The fan in Ex. 4 without front support is revolvable, in Ex. 1 is not revolvable.

Le poids dans le tableau inclut le moteur

The weight indicated in the table includes motor

■ Der Ventilator in Aus. 4, ohne Vorderhalterung, ist drehbar; in Aus. 1 ist nicht drehbar.

■ El ventilador en Ej. 4 sin soporte delantero es orientable, en Ej. 1 no es orientable.

Gewichtsbangabe in Tabelle inkl. Motor

El peso en la tabla incluye el motor

Ulteriori informazioni e quote:
 ■ Ulérieures informations et cotes:
 ■ Further information and sizes:
 ■ Weitere Infos und Größen:
 ■ Más informaciones y medidas:

TIPO - Type		PESO Weight Kg	PD² Kg x m²	B	I	H	H1	H2	J	K	M	Q	R	Ø
VENTILATORE Fan	MOTORE Motor													
PDB1000/P4R	180 M4	562	35	893	357	900	670	900	434	488	460	70	33	17
PDB1000/P4	180 L4	577	39	944	357	900	670	900	434	488	460	70	33	17
PDB1000/P/T		721	40			770	670	900						

pg./S. 4,6

pg./S. 4,5

