

Capacité 2,9 t x 1,4 m

Poids 1850 Kg - 2090 Kg

Longueur de flèche maximale 8,65 m

Hauteur de levage maximale 8,8 m

CACES 2B  
R 383 m

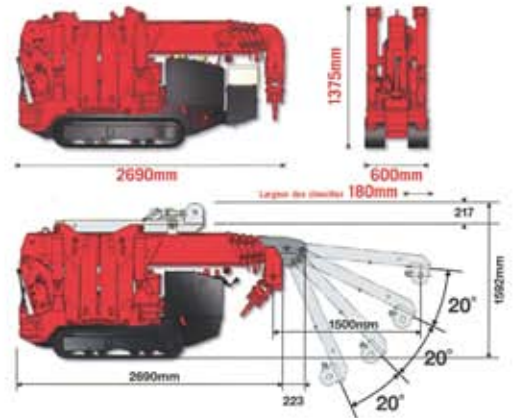

### Tableau de charge et positions du calage

