

PLEASE THINK BEFORE YOU PRINT

Specifications

SMART Board™ Interactive Display

Model SBID 6052i

Physical Specifications

Product size	50" W × 35 3/4" H × 7 1/4" D (127 cm × 91 cm × 18.5 cm)
Display/Interactive Area	52" (132 cm) diagonal, 16:9 format 45 3/8" W × 25 3/8" H (115 cm × 64.5 cm)
Product Weight	132 lb. (60 kg)
Shipping Size	42" W × 45 5/8" H × 57" D (107 cm × 116 cm × 145 cm)
Shipping Weight	193 lb. (87.5 kg) with pallet

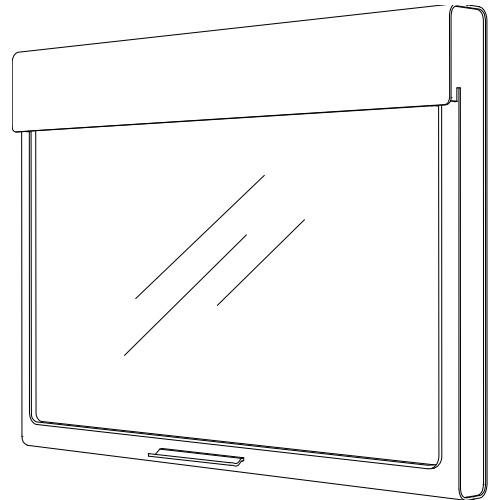

All dimensions +/- 1/8" (0.3 cm). All weights +/- 2 lb. (0.9 kg)

Standard Features

Software	SMART Product Drivers and either SMART Notebook™ software or SMART Meeting Pro™ Premium software. Upgrades are available at smarttech.com/st/en-US/Support/Downloads/ .
Digitizing Technology	DViT™ (Digital Vision Touch) technology uses digital cameras to track objects interacting with the display surface.
Wall-Mount Installation	Must be installed by a certified technician. Can use VESA standard flat panel installation mounts. Ensure mounting system can support product weight.

Extraordinary made simple™

SMART™

Mobile-Cart Installation	Must be installed by a certified technician. Integrates with the SMART Mobile Stand for Interactive Displays (document 131862). Allows mobility, convenient storage for computer (in cabinet or on an optional laptop shelf) and height adjustment.
Direct Screen Touch	Contact between a finger and the LCD panel is interpreted as a mouse click, enabling you to perform normal computer operations. Direct contact with the screen ensures there is no added parallax or image distortion.
Gestures	Supports multitouch gestures
Battery-Powered Pencil	The pencil communicates with the interactive display to draw or erase digital ink. Requires a AAA battery (included).
Pencil Ledge	The pencil ledge provides convenient storage for the pencil.
Controller Box	The controller box connects to two digital cameras, processes camera data and sends data to a connected computer or SMART Hub SE240.
Interactivity Connections	16' 6" (5 m) USB 2.0 cable connects the interactive display to the computer
Power Requirements (Touch System)	Switching power supply, 100-240V AC, 50/60 Hz, 12V DC 5 A, 6' (1.8 m) power cable
Power Requirements (LCD Panel)	Switching power supply, 100-240V AC, 50/60 Hz, 4.9 to 2.0 A
Power Consumption	Up to 290 W
Environmental Compliance	EU RoHS, WEEE
Regulatory Certification	CB, CE, FCC
Warranty	Two-year, limited equipment warranty. See warranty documents included with product.
Display Specifications	See the <i>NEC MultiSync S521 User's Manual</i> (document 145185).

Computer Requirements

A computer or SMART Hub SE240 is required for the interactive display. Computer requirements vary based on the software package you select.

Interactive Displays with SMART Notebook software	<ul style="list-style-type: none">• A computer with either a Windows® or Mac operating system• See computer requirements in the SMART Notebook release notes (document 126571).
Interactive Displays with SMART Meeting Pro Premium software	<ul style="list-style-type: none">• A computer with the Windows operating system• See computer requirements in the SMART Meeting Pro Premium release notes (document 144278).

Storage and Operating Requirements

Operating Temperature	41°F to 95°F (5°C to 35°C)
Storage Temperature	-40°F to 120°F (-40°C to 49°C)
Humidity	5% to 80% relative humidity, non-condensing

Environmental Requirements

Before installing your SMART interactive display, review the following environmental requirements.

Water and Fluid Resistance	<ul style="list-style-type: none">• Intended for indoor use• Do not pour or spray liquids onto the electronic components
Electrostatic Discharge (ESD)	<ul style="list-style-type: none">• Designed to withstand electrostatic shock• EN61000-4-2 severity level 3 for direct and indirect ESD (± 4 kV Contact / ± 8 kV Air)
Conducted and Radiated Emissions	<ul style="list-style-type: none">• FCC part 15 Class A• EN55022 / CISPR 22• KN55022
Flammability Rating	<ul style="list-style-type: none">• Electronics and connectors: UL 94-V0• Mechanical parts: UL 94-HB• USB 2.0 cable: UL VW-1 / CSA FT4
Quality Assembly	<ul style="list-style-type: none">• All cables: IPC/WHMA-A-620 Class 2 workmanship standards for <i>Requirements and Acceptance for Cable and Wire Harness</i>• Digital cameras, controller box and pencil circuit boards: IPC-A-610 standards for <i>Acceptability of Electronic Assemblies</i>, to Class 2 specifications (Dedicated Service Electronic Parts)

SMART Order Numbers

SBID 6052i B	SMART Board Interactive Display, black bezel. Includes a SMART Notebook software installation CD.
SBID 6052i B-MPP	SMART Board Interactive Display, black bezel. Includes an activation key for the SMART Meeting Pro Premium software download. Requires a computer with a Windows operating system.
SBID 6052i W	SMART Board Interactive Display, white bezel. Includes a SMART Notebook software installation CD.
SBID 6052i W-MPP	SMART Board Interactive Display, white bezel. Includes an activation key for the SMART Meeting Pro Premium software download. Requires a computer with a Windows operating system.

Optional Accessories

SMART Hub SE240	An alternative to using a computer to provide basic whiteboarding for the interactive display. Doesn't support SMART Meeting Pro Premium or SMART Notebook without another computer.
FSSBID 100	SMART Mobile Stand for interactive displays. Allows mobility and 15 3/4" (40 cm) of height adjustment.
FSSBID 100H	SMART Mobile Stand for interactive displays for SMART Hub SE240. Allows mobility and 15 3/4" (40 cm) of height adjustment.
FSSBID LTS	Optional laptop shelf, featuring an adjustable tilt angle of up to 35° from horizontal. Shelf telescopes outward.
FSSBID RACK MT	Rack mount hardware accessory kit. Includes 16 rack clips.
SBID 6052i-PEN	Black replacement pencil
IDF-PEN NIBS	Interactive display pencil replacement nibs (10 pack)

Physical Dimensions

Front View

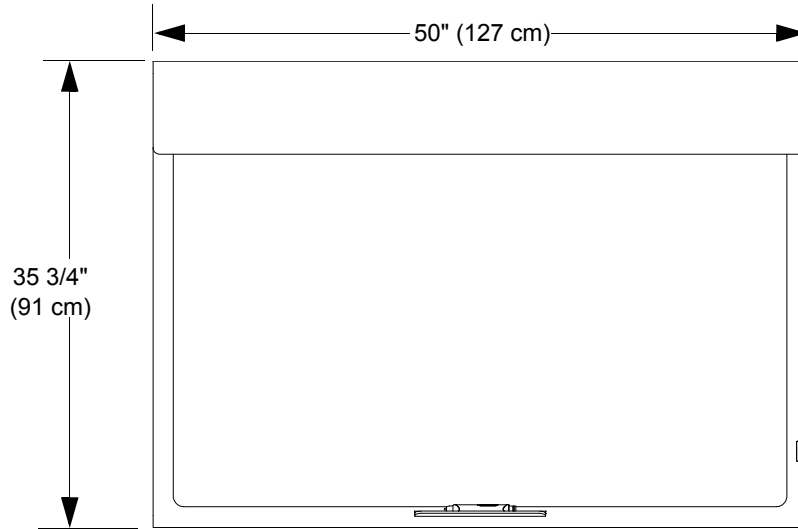

Back View

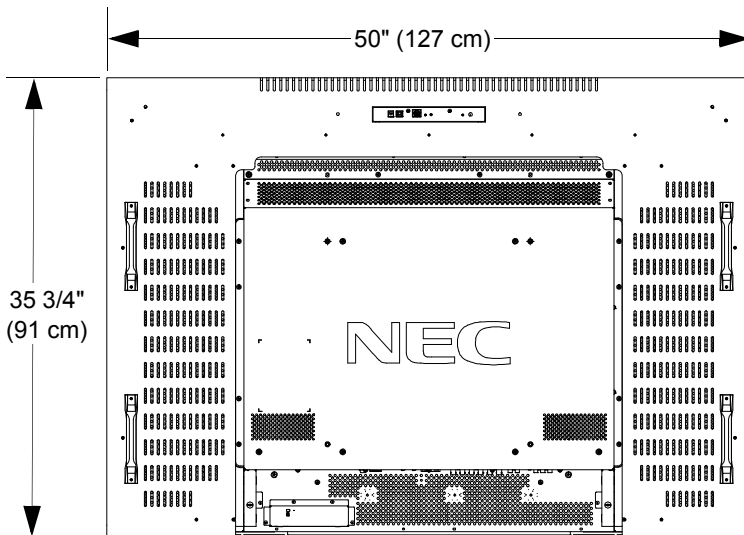

Side View

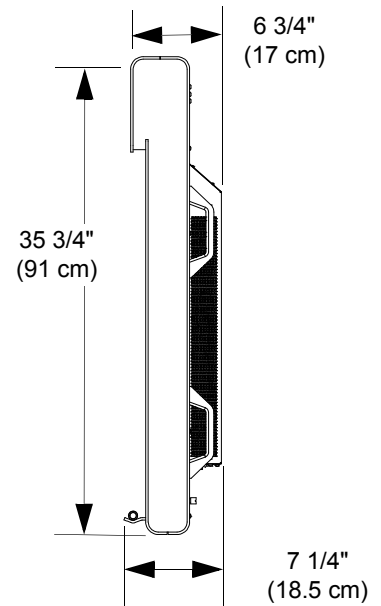

6 | SPECIFICATIONS – SMART BOARD INTERACTIVE DISPLAY –
MODEL SBID 6052I

Top View

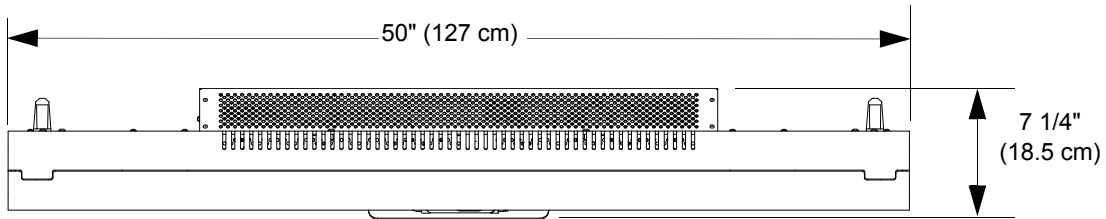

Pencil Side View

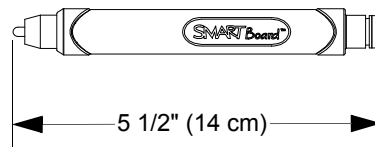

www.smarttech.com/support www.smarttech.com/contactsupport
Support +1.403.228.5940 or Toll Free 1.866.518.6791 (U.S./Canada)



©2010 SMART Technologies ULC. All rights reserved. SMART Notebook, SMART Meeting Pro, SMART Board, DVIT, the SMART logo and smarttech are trademarks or registered trademarks of SMART Technologies ULC in the U.S. and/or other countries. Windows is either a registered trademark or a trademark of Microsoft Corporation in the U.S. and/or other countries. All other third-party product and company names may be trademarks of their respective owners. Patent No. US6320597; US6326954; US6741267; US6803906; US6947032; US6954197; US6972401; US7151533; US7236162; US7411575; US7499033; US7619617; US7643006; CA2252302; CA2453873; EP1297488; ES2279823; ZL0181236.0; and DE60124549. Other patents pending. Contents are subject to change without notice. 03/2010.