

BRIDA PLANA INOXIDABLE FORJADA EN 1092-1 Tipo 01 - PN 10/16/40

STAINLESS STEEL FORGED PLATE FLANGE EN 1092-1 Type 01 - PN 10/16/40



PN 10/16/40

AISI 316L

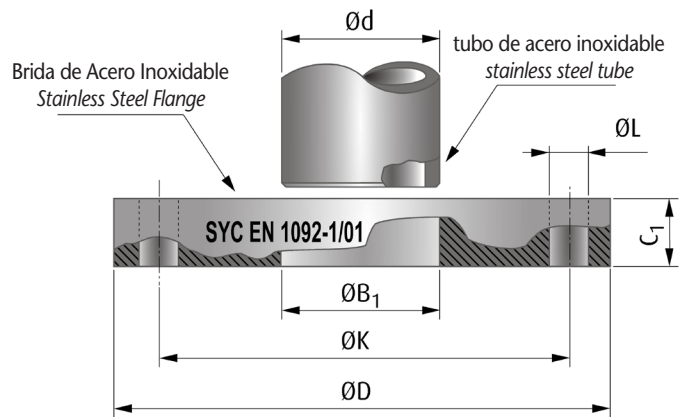

INFORMACIÓN TÉCNICA - TECHNICAL INFORMATION

Designación - Designation				Brida - Flange						Tornillos - Bolting		Peso aprox. Weight approx. (kg)
COD.	Tubo de Acero Steel tube			PN	Diámetro exterior Outside diameter	Diámetro del círculo para tornillos Diameter of bolt circle	Diámetro para tornillo Diameter of bolt hole	Diámetro interior Bore diameter	Espesor Thickness	Número Number	Diámetro Diameter	
	DN	NPS	Ød (mm)									
IF614015	15	1/2"	21,3	40	95 ± 2,0	65 ± 1,0	14 +1,0/0	22,0 ± 0,5/0	14 +1,0/-1,3	4	M12	0,71
IF614020	20	3/4"	26,9	40	105 ± 2,0	75 ± 1,0	14 +1,0/0	27,5 ± 0,5/0	16 +1,0/-1,3	4	M12	0,98
IF614025	25	1"	33,7	40	115 ± 2,0	85 ± 1,0	14 +1,0/0	34,5 ± 0,5/0	16 +1,0/-1,3	4	M12	1,16
IF614032	32	1 1/4"	42,4	40	140 ± 2,0	100 ± 1,0	18 +1,0/0	43,5 ± 0,5/0	18 +1,0/-1,3	4	M16	1,62
IF614040	40	1 1/2"	48,3	40	150 ± 2,0	110 ± 1,0	18 +1,0/0	49,5 ± 0,5/0	18 +1,0/-1,3	4	M16	1,86
IF616050	50	2"	60,3	40	165 ± 2,0	125 ± 1,0	18 +1,0/0	61,5 ± 0,5/0	20 ± 1,5	4	M16	2,47
I6576065 ²⁾	65	2 1/2"	76,1	16	185 ± 2,0	145 ± 1,0	18 +1,0/0	77,5 ± 0,5/0	18 +1,0/-1,3	4	M16	3,00
IF616065	65	2 1/2"	76,1	16	185 ± 2,0	145 ± 1,0	18 +1,0/0	77,5 ± 0,5/0	20 ± 1,5	8	M16	3,16
IF616080	80	3"	88,9	16	200 ± 2,0	160 ± 1,0	18 +1,0/0	90,5 ± 0,5/0	20 ± 1,5	8	M16	3,77
IF616100	100	4"	114,3	16	220 ± 2,0	180 ± 1,0	18 +1,0/0	116,0 ± 0,5/0	22 ± 1,5	8	M16	4,03
IF616125	125	5"	139,7	16	250 ± 2,0	210 ± 1,0	18 +1,0/0	141,5 +1,0/0	22 ± 1,5	8	M16	5,60
IF616150	150	6"	168,3	16	285 ± 2,0	240 ± 1,0	22 +1,0/0	170,5 +1,0/0	24 ± 1,5	8	M20	6,57
IF611200	200	8"	219,1	10	340 ± 3,0	295 ± 1,0	22 +1,0/0	221,5 +1,0/0	24 ± 1,5	8	M20	10,00
IF616200	200	8"	219,1	16	340 ± 3,0	295 ± 1,0	22 +1,0/0	221,5 +1,0/0	26 ± 1,5	12	M20	9,31
IF611250	250	10"	273,0	10	395 ± 3,0	350 ± 1,0	22 +1,0/0	276,5 +1,0/0	26 ± 1,5	12	M20	12,15
IF616250	250	10"	273,0	16	405 ± 3,0	355 ± 1,0	26 +1,0/0	276,5 +1,0/0	29 ± 1,5	12	M24	13,40
IF611300	300	12"	323,9	10	445 ± 3,0	400 ± 1,0	22 +1,0/0	327,5 +1,0/0	26 ± 1,5	12	M20	14,05
I6502300 ¹⁾	300	12"	323,9	16	460 ± 3,0	410 ± 1,0	26 +1,0/0	327,5 +1,0/0	28 ± 1,5	12	M24	17,40
IF616300	300	12"	323,9	16	460 ± 3,0	410 ± 1,0	26 +1,0/0	327,5 +1,0/0	32 ± 1,5	12	M24	18,98
IF611350	350	14"	355,6	10	505 ± 3,0	460 ± 1,0	22 +1,0/0	359,5 +1,0/0	30 ± 1,5	16	M20	20,60
I6502350 ¹⁾	350	14"	355,6	16	520 ± 3,0	470 ± 1,0	26 +1,0/0	359,5 +1,0/0	30 ± 1,5	16	M24	26,00
IF616350	350	14"	355,6	16	520 ± 3,0	470 ± 1,0	26 +1,0/0	359,5 +1,0/0	35 ± 1,5	16	M24	28,20
IF611400	400	16"	406,4	10	565 ± 3,0	515 ± 1,0	26 +1,0/0	411,0 +1,0/0	32 ± 1,5	16	M24	28,50
I6502400 ¹⁾	400	16"	406,4	16	580 ± 3,0	525 ± 1,5	30 +2,5/0	411,0 +1,0/0	32 ± 1,5	16	M27	30,90
IF616400	400	16"	406,4	16	580 ± 3,0	525 ± 1,5	30 +2,5/0	411,0 +1,0/0	38 ± 1,5	16	M27	35,86
IF611450	450	18"	457,0	10	615 ± 3,0	565 ± 1,0	26 +1,0/0	462,0 +1,5/0	36 ± 1,5	20	M24	35,00
IF611500	500	20"	508,0	10	670 ± 3,0	620 ± 1,0	26 +1,0/0	513,5 +1,5/0	38 ± 1,5	20	M24	41,00
I6502500 ¹⁾	500	20"	508,0	16	715 ± 3,0	650 ± 1,5	33 +2,5/0	513,5 +1,5/0	38 ± 1,5	20	M30	54,00
IF616500	500	20"	508,0	16	715 ± 3,0	650 ± 1,5	33 +2,5/0	513,5 +1,5/0	46 ± 1,5	20	M30	64,02

1) Conforme DIN 2502 - According to DIN 2502.

2) Conforme DIN 2576 y DIN 2502 - According to DIN 2576 and DIN 2502.



INFORMACIÓN TÉCNICA - TECHNICAL INFORMATION

Designación - Designation				Brida - Flange							Tornillos - Bolting		Peso aprox. Weight approx. (kg)
COD.	Tubo de Acero Steel tube			PN	Diámetro exterior Outside diameter	Diámetro del círculo para tornillos Diameter of bolt circle	Diámetro para tornillo Diameter of bolt hole	Diámetro interior Bore diameter	Espesor Thickness	Número Number	Diámetro Diameter		
	DN	NPS	Ød (mm)		ØD (mm)	ØK (mm)	ØL (mm)	ØB ₁ (mm)	C ₁ (mm)	nr (n°)	Ø (mm)		
IF611600 ³⁾	600	24"	610,0	10	780 ± 5,0	725 ± 1,5	30 +2,5/0	616,5 +1,5/0	34 ± 1,5	20	M27	46,68	
IF611700 ³⁾	700	28"	711,0	10	895 ± 5,0	840 ± 1,5	30 +2,5/0	716,0 +3,0/0	34 ± 1,5	24	M27	59,21	
IF611800 ³⁾	800	32"	813,0	10	1015 ± 5,0	950 ± 1,5	33 +2,5/0	818,0 +3,0/0	38 ± 1,5	24	M30	82,61	

3) Bridas no normalizadas - Non-standard flanges.

CARACTERÍSTICAS BÁSICAS

- Brida conforme UNE-EN 1092-1 Tipo 01.
- Brida conforme DIN 2502 si señalada con 1) o DIN 2576 y DIN 2502 si señalada con 2).
- Material: Acero Inoxidable X2CrNiMo17-12-2 / 1.4404 (AISI 316L) conforme a UNE-EN 10222-5.
- Tipo de refrentado: Tipo A, Cara Plana.
- Todas las instalaciones deben cumplir los valores P-T según los requisitos legales especificados.

APLICACIONES GENERALES

- Sistemas de aguas generales.
- Instalaciones de Agua Potable.
- Plantas de abastecimiento, bombeo y acometidas de aguas.
- Aplicaciones industriales de agua, gas, vapor, condensados y aceites.
- Instalaciones Contra Incendios.
- Industria química, alimentaria, térmica y farmacéutica.
- Aire comprimido.

BASIC FEATURES

- Flange according to EN 1092-1 Type 01.
- Flange according to DIN 2502 if checked with 1) or DIN 2576 and DIN 2502 if checked with 2).
- Material: Stainless Steel X2CrNiMo17-12-2 / 1.4404 (AISI 316L) according to EN 10222-5.
- Flange facing type: Type A, Flat Face.
- All installations has to meet the P-T values specified in the legal requirements.

GENERAL APPLICATIONS

- Water systems.
- Installations of Water for Human consumption.
- Water supply, pumping and connection plants.
- Industrial applications of water, gas, steam, condensates and oils.
- Fire Fighting Installations.
- Chemical, food, thermal and pharmaceutical industries.
- Compressed air.

Nota : Debido al constante desarrollo de nuestros productos, los datos suministrados pueden ser alterados sin previo aviso.

Note : Due to the continuous development of our products, specifications may be changed without notification at any time.

Rev.0-05.19
2/2