

General Specifications

GS 04L52B01-01EN

GP10/GP20
Paperless Recorder
(Portable type)

GX90XA/GX90XD/GX90YD I/O Modules

SMARTDAC+TM

OVERVIEW

The GP10/GP20 are portable type paperless recorders that display real-time measured data on a touch screen and save data on an external storage medium (SD card).

- The number of measurement data is a maximum of 48 channels in GP10, and a maximum of 100 channels in GP20.
- The GP10/GP20 have the large internal memory (GP10/GP20: 500MB), and prolonged record and preservation are possible.
- As the input signal, a DC voltage, thermocouple, resistance temperature detector, or contact signal can be set to each channel.
- Input and output have module structure and it can extend them easily. (GP10: max. 3, GP20: max. 10)
- A module type is three types, an analog input, a digital input, and a digital output.
- The intuitive operation by flick, pinch in, pinch out, and swipe are possible.
- The past trend under recording can be seamlessly displayed on a trend screen.
- Moreover, the measurement data of the time specified on the calendar screen can be searched and displayed.
- Various functions, such as a freehand message, a PDF/Excel output of a report file, a direct output to a network printer, a scale movement of a trend display, and a buzzer sound, are equipped.
- It can be hooked up to network via Ethernet, which enables to inform by Email and to monitor on Web site as well as to transfer files by using FTP. Also, it can communicate with Modbus/RTU or Modbus/TCP.
- A setup of GP can be performed on-line from the web browser on PC. A setup by off-line is also possible.
- Universal Viewer software allows a PC to display waveforms on its screen and to print out waveforms.

MAIN UNIT SPECIFICATIONS

FUNCTIONAL SPECIFICATION

Input Specifications

Please see "INPUT/OUTPUT MODULE SPECIFICATIONS."

Display Functions

Display groups:

Number of groups; GP10: 30, GP20: 50
Number of channels that can be assigned to each group; GP10: 10, GP20: 20
Scan interval: 100, 200, 500 ms, 1, 2, 5 s

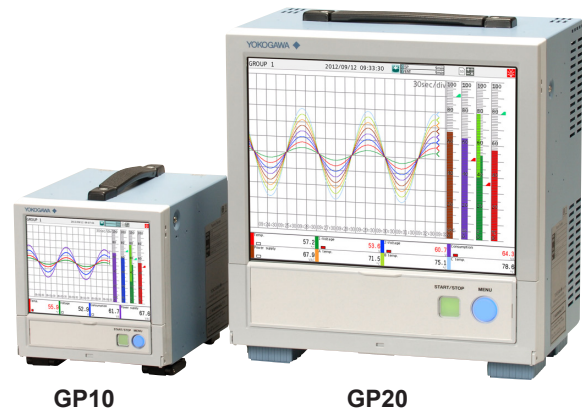

Display color (Trend/Bar graph/Digital display):

Channel: Select from 24 colors
A desired display color can be selected freely using its RGB value.
Background: Select from white or black

Display type:

- Trend display (T-Y)
Display method:
Direction: Horizontal, vertical
Trend interval: 5, 10, 15, 30 s/div, 1, 2, 5, 10, 15, 20, 30 min/div, 1, 2, 4, 10 h/div
Trend line width: Thick, normal, thin
Scale; GP10: Max. 6, GP20: Max. 10
Current value bar graph, color scale band, and alarm point marks can be displayed on the scale.
Moving scale; Scale can be moved on any waveform.
A bitmap image scale can be attached.
Others; Grid (Auto, 4 to 12), Trip line, Message, Zone display, Partial expanded display
- Historical trend display (T-Y display)
Redisplays the display data or event data in the internal memory or external storage medium
Time axis operation: The time axis can be reduced or expanded.
Data search: Waveforms from the internal memory can be displayed through the specification of a date and time, calendar, each summary
Moving scale; A bitmap image scale can be attached.
All historical trends can be displayed in one screen.
- Bar graph display
Direction: Vertical or horizontal
Scale: Display a scale for each channel
Color scale band, and alarm point marks can be displayed on the scale.

- Digital display
Displays measured values numerically
A DI input state can be displayed as an arbitrary character string (0=Off/1=On, etc.)
Update rate: 0.5 s
- Overview display
Display format: All channels (GP10: Max. 30, GP20: Max. 100), each groups
Displays the measured values of all channels and the alarm statuses
- Alarm summary display
Displays a log of up to 1000 alarms
Specify an alarm with the cursor and jump to the corresponding section on the historical trend display.
- Message summary display
Time and content of up to 500 messages (including 50 add messages)
Specify a message with the cursor and jump to the corresponding section on the historical trend display.
- Memory summary display
Displays the information (up to 500) of the data in the memory
Specify a file with the cursor and jump to the corresponding section on the historical trend display.
- Report display
Displays the report data residing in the internal memory
For more details, see "MATHEMATICAL FUNCTIONS WITH REPORT FUNCTION (/MT)."
- Log display
Displays the event log, error log, communication log, FTP log, Web log, e-mail log, SNTP log, DHCP log, and Modbus log.
- Multi-panel display
Divides the screen into two to six sections and displays some different display formats.
- Other displays
Network information display
System information display
System configuration display

Auto scroll:

The displayed groups can be automatically switched at a specified interval.
The display switches in ascending group order.

Names of channels:

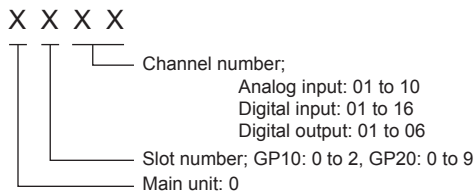

Tags:

- Tag and Tag numbers can be displayed.
- Tag number; Number of characters: Up to 16
Displayable characters: Alphanumeric characters
Tag numbers can be enabled or disabled.
- Tag; Number of characters: Up to 32
Displayable characters: Alphanumeric characters

Message:

- Write messages to the trend display.
- Number of messages: 100
- Number of characters: Up to 32
- Write method: Write a preset message or write an arbitrary message on the spot.
- Write destination: Select only the displayed group or all groups.
- Auto message: Write a message when the GP recovers from a power failure while memory sampling is in progress.
Write a message when the trend interval is switched during memory sampling.

Add message:

- Write messages to the past data positions.
- Message: The same as the "Message" item above
Number of writable messages per file: 50 messages (including 10 freehand messages)

Freehand message:

- Can be written by dedicated pen.
Number of writable messages per file: 50 messages (including 10 Add messages)

Data Saving Functions

Internal memory:

- Temporarily saves various types of data.
- Medium: Flash memory
- File storage capacity: 500 MB

External storage medium:

- Medium SD card (SD/SDHC) (up to 32 GB)
- Format: FAT32 or FAT16

Data type:

- Display data, Event data, Alarm summary data, Manual sampled data, Screen image data, Setup data, and Report data

Display data:

- Target: Measurement (input/output module)/math/communication channels, alarm summary, message summary
Description: Maximum or minimum value per recording interval
- Recording intervals: Determined by the trend interval
For GP20

Trend interval (div)	Number of channels
5 s	100
10 s	200
15 s or longer	500

Note that the maximum number of channels is fixed at 100 in the GP10.

- Data size;
Analog input data: 12 bytes/ch.
Digital I/O data: 4 bytes/ch.
Math channel data: 12 bytes/ch.
Communication channel data: 12 bytes/ch.
- File size: Up to 18 MB
- Number of files: Up to 500 (including event data)
- Operation in the internal memory: FIFO (First In First Out)
- Data format: Binary or text
- Recording: Records data at all times.

- Display data file sample time
Measurement channel = 30. Math Channel = 0

Internal Memory	500 MB
Display update (minute/div)	30 minutes
Recording interval (s)	60 s
Total sample time	Approx. 2.5 years

Event data:

- Target: Measurement (input/output module)/ math/communication channels, alarm summary, message summary, operation log
Description: Instantaneous value per recording interval
- Recording intervals: Determined by the sample rate
For GP20

Sampling rate	Number of channels
100 ms	100
200 ms	200
500 ms or longer	500

Note that the maximum number of channels is fixed at 100 in the GP10.

- Data size;
Analog input data: 6 bytes/ch.
Digital I/O data: 2 bytes/ch.
Math channel data: 6 bytes/ch.
Communication channel data: 6 bytes/ch.
- File size: Up to 18 MB
- Number of files: Up to 500 (including display data)
- Operation in the internal memory: FIFO (First In First Out)
- Data format: Binary or text
- Mode; Free: Records data at all times.
Trigger: Starts recording data when a certain event occurs and records for the specified interval.
Repetition trigger: Repeat Trigger mode
- Event data file sample time
Measurement channel = 30. Math Channel = 0

Internal Memory	500 MB
Recording period (s)	1 s
Total sample time	Approx. 1 month

Alarm Functions

- Number of alarms: Up to four alarms (level) for each measurement channels
- Alarm type: High limit, low limit, difference high limit, difference low limit, high limit on rate-of-change alarm, low limit on rate-of-change alarm, delay high limit, and delay low limit
- Alarm delay time: 1 s to 24 hours (for each channel)
- Rate-of-change calculation interval of rate-of-change alarms: 1 to 32 times the scan interval (common to all channels)
- Hysteresis: 0.0 to 5.0% of the span (for each alarm (level))
- Alarm output: Output to the internal switch
Internal switch operation: AND/OR operation selectable

- Display: Displays the status on the respective operation screen and an alarm icon on the status display section when an alarm occurs.
Display operation: Hold or not hold the display until the alarm acknowledge operation
- Alarm hide function (alarm no logging function)
Not display alarms nor record to the alarm summary (for each channel)
- Alarm information: Displays a log of alarm occurrences on the alarm summary
- Reflash: The duration for which the reflash relays are deactivated can be set to 500 ms, 1 s, or 2 s.

Event Action Functions

- Event action: Execute a specified operation when a given event occurs.
- Number of settings: 50
Events: Remote control input, etc.
Timer; Number of timers: 4
Match time timer; Number of timers: 4
Action: Specify memory start/stop, alarm ACK, etc.

Security Functions

- Operation lock function: Limitations to touch operation, access to the external storage medium, and various operations
- Login function: Only registered users can operate the GP.
It can be set to each of touch operation and communication access.
System administrators and Users: 50 (totally)
Number of Authority of user: 10 level

Manual Sampled Data

- Item: Instantaneous value at an arbitrary time
- Target: Measurement (input/output module)/ math/communication channels
- Number of recording channels: Max. 50
- Maximum number of data values that the internal memory can store: 400
- Data format: Text

Report Data

- Item: Report at each scheduled time of report
- Target: Measurement (input/output module)/ math/communication channels
- Maximum number of reports that the internal memory can store: 800
- Data format: Text

Snapshot Data

- Item: Displayed screen image data
- Data format: PNG
- Output destination: External medium or communication output

Setup Data

- Item: GP setup data
- Data format: text
- Output/read destination (for saving/loading): External medium

Clock Functions

- Clock: With a calendar function
- Accuracy: ± 5 ppm (0 to 50°C), excluding a delay (of 1 second, maximum) caused each time the power is turned on.
- Time setting: Using touch operation, communication command, event action function, or SNTP client function
- Time adjustment method:
Limit in which the time is gradually adjusted: Select from the available settings between 5 s and 15 s.
Whether to change an out-of-limit operation immediately or report it as an error can be selected.
While memory sampling: Corrects the time by 1 ms for each second.
While memory is stopped: Immediately change the time.
- DST: The date/time for switching between standard time and DST can be specified.
- Time zone: Sets the time difference from GMT.
- Date format: Select "YYYY/MM/DD", "MM/DD/YYYY", "DD/MM/YYYY" or "DD.MM.YYYY".
MM expression can be selected from the numeric character or ellipsis. Ex. January: 01 or Jan
The delimiter can be selected from "/", ".", "-".

Ethernet Communication Functions

- Electrical specifications: Conforms to IEEE 802.3
- Connection: Ethernet (10BASE-T/100BASE-TX)
- Max. segment length: 100 m
- Max. connecting configuration: Cascade Max. 4 level (10BASE-T), Max. 2 level (100BASE-TX)
- Connector: RJ-45
- Protocols: TCP, UDP, IP, ICMP, ARP, DHCP, HTTP, FTP, SMTP, SNTP, Modbus, and dedicated protocols
- E-mail client: Automatically send e-mail at specified times.
E-mail is sent by events as below.
 - Alarm occurring/alarm canceling
 - Recover from power failure
 - Report data generating
 - Storage medium error, FTP client function error
 - Specified time period
 POP before SMTP and SMTP authentication (PLAIN and CRAM-MD5) is available.
- FTP client: Automatically transfer data files to the FTP server.
Applicable files: Display data, event data, screen image data, report data, etc.
- FTP Server: Transfer files, delete files, manipulate directories, and output file lists of the GP.
- Web server: GP real-time monitoring and setting changes/operations can be performed with the Web browser.
- SNTP client: Inquires the time to the SNTP server and sets the GP.
- SNTP server: Outputs the GP time.
Time resolution: 5 ms
- DHCP client: Automatically obtain the network address settings from the DHCP server.

- Modbus client: Reads data from another device and writes to the registers.
- Modbus server: Loads measurement and math channel data
Loads and writes communication channel data
Some control commands such as memory start Modbus client* register access limitations
*: Required /MC option
- Setting/Measurement server: Operate, set, and output data of the GP using a dedicated protocol.

Batch Function

- Function: Data management using batch names. Enter text fields and batch comments in the data file.
- Batch name: Added to the file name of the display data and event data.
Structure: Batch number (up to 32 characters) + lot number (up to 8 digits)
Use/not use selectable for lot number, on/off selectable for auto increment function.
- Text field: Adds text to the display data and event data.
There are 24 available text fields.
Up to 20 title characters and 30 other characters can be entered per field.
- Batch comment: Adds text to the display data and event data.
3 comments (max. 50 characters) are available.

Printer Output Function

- Snapshot Data can be printed out with any LAN-connected printer supporting the HP-PCL5 language.

Other Functions

- Buzzer: GP makes a buzzer sound at touch screen operation, or when alarm occurs.
- Backlight saver function: Dim or turn off the LCD backlight if there is no key operation for a specified time.
- Favorite display: Register frequently used displays to the Favorite and show them through simple operation.

■ HARDWARE SPECIFICATIONS (MAIN UNIT)

Display

Display unit*:

GP10: 5.7-inch TFT color LCD (640 × 480 dots)
 GP20: 12.1-inch TFT color LCD (800 × 600 dots)

* A small number of missing or steady-on LCD pixels and minor variations in brightness uniformity is a normal display characteristic and not a malfunction.

Touch screen:

4 wire resistive touch screen

Construction

- Material;
Case: Metal plate
Bezel and display cover: Polycarbonate
- Color;
Case: Smoke blue
Bezel: Charcoal grey light
- External dimensions:
When installing modules
GP10: 144(W) × 168(H) × 248(D) mm
GP20: 288(W) × 318(H) × 248(D) mm
When uninstalling modules
GP10: 144(W) × 168(H) × 197(D) mm
GP20: 288(W) × 318(H) × 197(D) mm
(D: depth from the panel mounting plane)
- Weight:
GP10: Approx. 1.9 kg, GP20: Approx. 5.7 kg (excluding modules)

Power Supply

- Rated supply voltage: 100 to 240 VAC
- Allowable power supply voltage range: 90 to 132, 180 to 264 VAC
- Rated power supply frequency: 50/60 Hz
- Power consumption:

Supply voltage	LCD backlight off	Normal operation	Maximum
100 VAC	GP10: 16 VA GP20: 28 VA	GP10: 20 VA GP20: 34 VA	GP10: 48 VA GP20: 90 VA
240 VAC	GP10: 24 VA GP20: 38 VA	GP10: 30 VA GP20: 45 VA	GP10: 60 VA GP20: 110 VA

* The following combinations are assumed for LCD backlight off and normal operation.

GP10: 1 AI module, 1 DO module, 1 DI module
 GP20: 5 AI modules, 4 DO modules, 1 DI module

- Module power supply voltage: The total allowable power consumption of respective modules is up to 6 W in the GP10 and up to 20 W in the GP20.
- Allowable interruption time: Less than 1 cycle of the power supply frequency

Isolation

- Insulation resistance: Between the Ethernet, RS-422/485, and each insulation terminals and earth: 20 MΩ or greater at 500 VDC
- Withstand voltage:
Between the power terminal and earth: 3000 V AC at 50/60 Hz for one minute
Between the contact output terminal and earth: 3000 VAC at 50/60 Hz for one minute
Between the input/output modules and earth: Depends on the specification of I/O module.
- Ground; Grounding resistance: 100 Ω or less
- Isolation:

Power terminal	FAIL output terminal	Internal circuit
	Ethernet port	
	RS-422/485 terminal	
	Input and output module terminal	
	Input and output module internal circuit	
	Earth (PE) terminal	
	RS-232 terminal SD card slot USB port	

The circuits divided by lines are insulated mutually.

Safety and EMC Standards

- CSA: CSA22.2 No.61010.1, installation category II (*1), and pollution degree 2 (*2), and CSA-C22.2 NO. 61010-2-030-12
 - UL: UL61010-1, UL 61010-2-030 (CSA NRTL/C)
 - CE:
EMC directive
EN61326-1 compliance, Class A Table 2
EN61000-3-2 compliance
EN61000-3-3 compliance
EN55011 Class A Group 1
Low voltage directive
EN61010-1, EN 61010-2-030
Installation category II (*1)
Pollution degree 2 (*2)
Measurement category II (*3)
 - C-Tick: EN55011 compliance, Class A Group 1
 - KC marking: Electromagnetic wave interference prevention standard, electromagnetic wave protection standard compliance
- *1 Installation category (overvoltage category) II: Describes a number which defines a transient overvoltage condition. Implies the regulation for impulse withstand voltage. "II" applies to electrical equipment which is supplied from the fixed installation like a distribution board.
- *2 Pollution degree 2: Describes the degree to which a solid, liquid, or gas which deteriorates dielectric strength or surface resistivity is adhering. "2" applies to normal indoor atmosphere. Normally, only non-conductive pollution occurs.
- *3 Measurement category: Depends on the specification of each modules

Category	Measurement category	Description	Remarks
II	CAT II	Available in the testing and measuring circuits directly connected to a usage location (receptacle or the like) of a low-voltage main power supply facility.	Appliances, portable equipment, etc.
III	CAT III	Available in the testing and measuring circuits connected to a power distribution portion of a low-voltage main power supply facility.	Distribution board, circuit breaker, etc.
IV	CAT IV	Available in the testing and measuring circuits connected to a power source of a low-voltage main power supply facility.	verhead wire, cable systems, etc.

- WEEE Directive: Compliant

Normal Operating Conditions:

- Power supply voltage: 100 to 240 V AC $\pm 10\%$
- Power supply frequency: 50/60Hz $\pm 2\%$
- Ambient temperature: 0 to 50°C
- Ambient humidity: 20 to 80 %RH (at 5 to 40°C) (no condensation)
- Magnetic field: 400 A/m or less (DC and 50/60 Hz)
- Vibration (IEC-60068-2-6):
Power supply ON, 3 directions, 10 cycles, 1 oct/min ($\pm 10\%$)
5 $\leq f < 8.4$ Hz amplitude 3.5 mm (peak)
8.4 $\leq f \leq 160$ Hz acceleration 9.8 m/s² (peak)
- Shock (IEC-60068-2-27):
Non-energization, 500 m/s², approximate 10 ms, 6 directions ($\pm X, \pm Y, \pm Z$), 3 times in each direction
- Mounting position: Can be inclined up to 30 degrees backward. Left and right horizontal.
- Altitude: 2000 m or less
- Installation location: Indoors
- Warm-up time: At least 30 minutes after power on

Other Specifications:

- Memory backup: A built-in lithium battery backs up the settings and runs the clock
- Recommended replacement periods of Battery: Approximately 10 years (at room temperature)

Transport and Storage Conditions:

- Ambient temperature: -25 to 60°C
- Ambient humidity: 5 to 95 %RH (no condensation)
- Vibration: 10 to 60 Hz, 4.9 m/s² maximum
- Shock: 392 m/s² maximum (in packaged condition)

EXTERNAL DIMENSIONS AND PANEL CUTOUT DIMENSIONS

GP10:

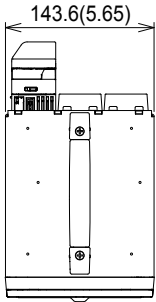

Unit: mm (approx. inch)
Unless otherwise specified,
tolerance is ±3% (however,
tolerance is ±0.3 mm when
below 10 mm).

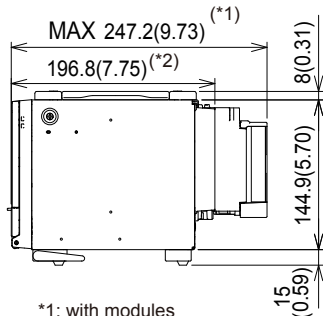
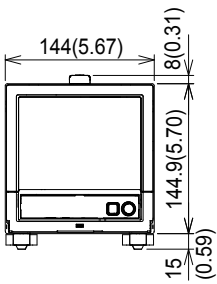

*1: with modules
*2: without modules

GP20:

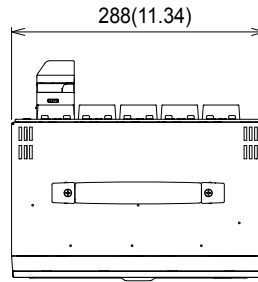

Unit: mm (approx. inch)
Unless otherwise specified,
tolerance is ±3% (however,
tolerance is ±0.3 mm when
below 10 mm).

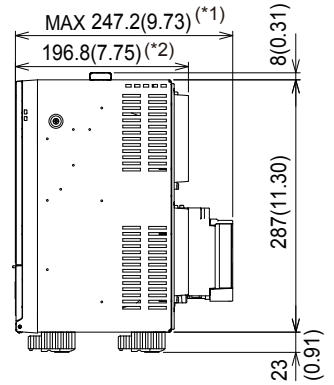
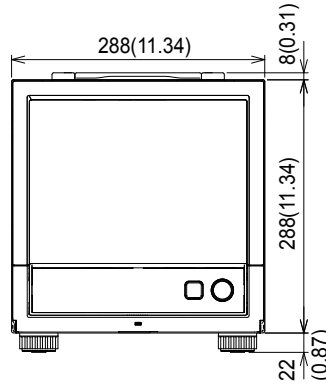

*1: with modules
*2: without modules

Rear view

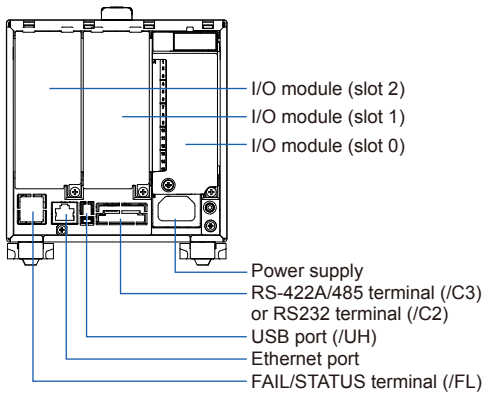

Rear view

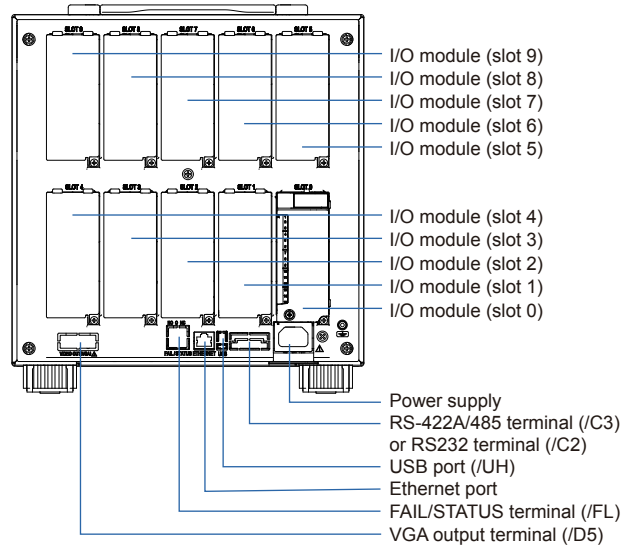

■ SPECIFICATIONS OF OPTIONAL FUNCTIONS

SERIAL COMMUNICATION INTERFACE (/C2, /C3)

- Connection: EIA RS-232(/C2) or EIA RS-422/485(/C3)
- Protocol: Dedicated protocol or Modbus protocol
- Setting/measurement server function: Operation, setting or output of measurement data are available by dedicated protocol.
- Synchronization: Start-stop synchronization
- Transmission mode (RS-422/485):
RS-422: Four-wire half-duplex multi-drop connection (1:n (n = 1 to 31))
RS485: Two-wire half-duplex multi-drop connection (1:n (n = 1 to 31))
- Baud rate: 1200, 2400, 4800, 9600, 19200, 38400, 57600, or 115200 bps
- Data length 7 or 8 bits
- Start bit: 1 bit
- Stop bit: 1 bit or 2 bit
- Parity: ODD, EVEN, or NONE
- Handshaking Off: Off, XON: XON, XON: RS, and CS: RS
- Communication distance; RS-422/485: 1200 m, RS-232: 15 m
- Modbus/RTU communication: Reading or writing of measurement data on other instruments is available by Modbus protocol.
Math channel option is needed to read measurement data from other instruments.
- Operation modes: Master or slave

VGA VIDEO OUTPUT (/D5) (Only for GP20)

- External display:
Resolution: 800 × 600 dots (VGA)
Connector: 15-pin D-Sub

FAIL OUTPUT (/FL)

- Contact: C contact, 1 point
- FAIL output:
The relay contact output on the rear panel indicates the occurrence of CPU failure.
Relay operation: Energized during normal operation and de-energized on CPU failure.
- Rated power supply voltage: 24 V DC or 250 V AC or less
- Rated load current: 3A (DC)/3A (AC), resistance load
- Min. load current: 100 mA
- Recommended replacement periods of contact:
Electrical: 30,000 more ON-OFF operations,
Mechanical: 5,000,000 more ON-OFF operations

MATHEMATICAL FUNCTIONS WITH REPORT FUNCTION (/MT)

Mathematical Function:

- Number of math channels; GP10: 50, GP20: 100
- Operation:
General arithmetic operations: Four arithmetic operations (+, -, *, /), square root, absolute, common logarithm, natural logarithm, exponential, and power
Relational operations: <, ≤, >, ≥, =, and ≠
Logic operations: AND, OR, NOT, and XOR
Statistical operations: TLOG or CLOG
Special operations: PRE, HOLD, RESET, and CARRY
Conditional operation: [a?b:c]
- Computation accuracy: Double-precision floating point
- Data that can be used;
Channel data: Measurement channels (GP10: 0001 to 0216, GP20: 0001 to 0916), mathematical channels (GP10: A001 to A050, GP20: A001 to A100), Communication channels (GP10: C001 to C050, GP20: C001 to C300)
Constants: 100 (K001 to K100), Internal switch: 100 (S001 to S100), Flag: 20 (F01 to F20)

Report function:

- Number of report channels; GP10: 50, GP20: 60
- Report types: Hourly + daily, daily + weekly, daily + monthly, Batch, Day custom
- Computation types: Average, maximum, minimum, sum, or instantaneous value
- Unit of sum: OFF, /s, /min, /hour, /day
- Report templates: Office Open XML spreadsheet files (which can be displayed with Microsoft Office Excel) or PDF files can be output or printed out with any LAN-connected printer supporting the HP-PCL5 language.

COMMUNICATION CHANNEL FUNCTIONS (/MC)

- Number of communication channels; GP10: 50 (C0001 to C050), GP20: 300 (C001 to C300)

USB INTERFACE (/UH)

- USB port: Complies with USB 2.0 and host function
- Number of ports: 2 (one each on the front panel and rear panel)
- Connectable devices: Only connect the devices listed below to prevent damage to the devices.
 - Keyboard: Complies with HID Class Ver. 1.1 104/89 keyboard (US) and 109/89 keyboard (Japanese)
 - Mouse: Complies with HID Class Ver. 1.1
 - External medium: USB flash memory
 - Does not guarantee the operation of all USB flash memories
 - External medium such as a hard disk, ZIP, MO, and optical discs are not supported.
 - Barcode reader: USB HID Class Ver. 1.1 compatible
 - English (U.S.) standard USB keyboard compatible
- Power supply: 5 V \pm 10%, 500 mA *1
 - *1: Devices which need more than 500 mA total bus power for 2 ports cannot be connected at the same time.
 - For low powered devices (bus power < 100 mA):
5V \pm 5%
 - For high powered devices (bus power < 500 mA):
5V \pm 10%

INPUT/OUTPUT MODULE SPECIFICATIONS

ANALOG INPUT MODULE (Model GX90XA or Option /Uxx0)

- Number of inputs: 10
- Input Type: DC voltage, standard signal, thermocouple (TC), resistance temperature detector (RTD), ON/OFF input (DI), and DC current (by adding an external shunt resistor)
- Measurement interval: 100, 200, 500 ms, 1, 2, 5 s
- Input range: -5% or more and 105% or less (accuracy is guaranteed in the range from 0% to 100% inclusive)
- Measurement ranges and accuracies (However, the number of display digits can be increased by scaling.)



GX90XA

* The following specifications apply to operation of the recorder under standard operation conditions. Temperature: 23 ± 2 °C, Humidity: 55% ± 10% RH, Power supply voltage: 90 to 132 or 180 to 250 VAC, Power supply frequency: 50/60 Hz ± 1%, Warm-up time: At least 30 min. Other ambient conditions such as vibration should not adversely affect recorder operation.

Input Type		Range	Measurement accuracy (digital display)		Max. resolution of digital display
			A/D integration time: 16.7ms or more	A/D integration time: 1.67ms	
DCV	20 mV	-20.000 to 20.000 mV	±(0.05 % of rdg + 12 µV)	±(0.1 % of rdg + 40 µV)	1 µV
	60 mV	-60.00 to 60.00 mV	±(0.05 % of rdg + 0.03 mV)	±(0.1 % of rdg + 0.15 mV)	10 µV
	200 mV	-200.00 to 200.00 mV	±(0.05 % of rdg + 0.03 mV)	±(0.1 % of rdg + 0.4 mV)	10 µV
	1 V	-1.0000 to 1.0000 V	±(0.05 % of rdg + 1.2 mV)	±(0.1 % of rdg + 4 mV)	100 µV
	2 V	-2.0000 to 2.0000 V	±(0.05 % of rdg + 1.2 mV)	±(0.1 % of rdg + 4 mV)	100 µV
	6 V	-6.000 to 6.000 V	±(0.05 % of rdg + 3 mV)	±(0.1 % of rdg + 15 mV)	1 mV
	20 V	-20.000 to 20.000 V	±(0.05 % of rdg + 3 mV)	±(0.1 % of rdg + 40 mV)	1 mV
	50 V	-50.00 to 50.00 V	±(0.05 % of rdg + 0.03 V)	±(0.1 % of rdg + 0.15 V)	10 mV
Standard signal	0.4-2V	0.3200 to 2.0800 V	±(0.05 % of rdg + 1.2 mV)	±(0.1 % of rdg + 4 mV)	100 µV
	1-5V	0.800 to 5.200 V	±(0.05 % of rdg + 3 mV)	±(0.1 % of rdg + 15 mV)	1 mV
TC (Excluding RJC accuracy, burnout detection OFF)	R	0.0 to 1760.0 °C	±(0.15 % of rdg + 1.0 °C) However, R, S; 0.0 to 800.0 °C: ±2.2 °C, B; 400.0 to 800.0 °C: ±3.0 °C Accuracy at less than 400.0 °C is not guaranteed.	±(0.2 % of rdg + 6.0 °C) However, R, S; 0.0 to 800.0 °C: ±7.6 °C, B; 400.0 to 800.0 °C: ±11.0 °C Accuracy at less than 400.0 °C is not guaranteed.	0.1 °C
	S	0.0 to 1760.0 °C			
	B	0.0 to 1820.0 °C			
	K	-270.0 to 1370.0 °C	±(0.15 % of rdg + 0.7 °C) However, -200.0 to 0.0 °C: ±(0.35 % of rdg + 0.7 °C) Accuracy at less than -200.0 °C is not guaranteed	±(0.2 % of rdg + 5.0 °C) However, -200.0 to 0.0 °C: ±(3 % of rdg + 5.0 °C) Accuracy at less than -200.0 °C is not guaranteed	0.1 °C
		-200.0 to 500.0 °C			
	E	-270.0 to 800.0 °C	±(0.15 % of rdg + 0.5 °C) However, -200.0 to 0.0 °C: ±(0.35 % of rdg + 0.5 °C) Accuracy at less than -200.0 °C is not guaranteed	±(0.2 % of rdg + 4.0 °C) However, -200.0 to 0.0 °C: ±(2 % of rdg + 4.0 °C) Accuracy at less than -200.0 °C is not guaranteed	0.1 °C
	J	-200.0 to 1100.0 °C			
	T	-270.0 to 400.0 °C	±(0.15 % of rdg + 0.5 °C) However, -200.0 to 0.0 °C: ±(0.35 % of rdg + 0.5 °C) Accuracy at less than -200.0 °C is not guaranteed	±(0.2 % of rdg + 2.5 °C) However, -200.0 to 0.0 °C: ±(2 % of rdg + 2.5 °C) Accuracy at less than -200.0 °C is not guaranteed	0.1 °C
	N	-270.0 to 1300.0 °C	±(0.15 % of rdg + 0.7 °C) However, -200.0 to 0.0 °C: ±(0.7 % of rdg + 0.7 °C) Accuracy at less than -200.0 °C is not guaranteed	±(0.3 % of rdg + 6.0 °C) However, -200.0 to 0.0 °C: ±(5 % of rdg + 6.0 °C) Accuracy at less than -200.0 °C is not guaranteed	0.1 °C
	W	0.0 to 2315.0 °C	±(0.15 % of rdg + 1.5 °C)	±(0.3 % of rdg + 14.0 °C) However, more than 1000.0 °C: ±(0.8 % of rdg + 9.0 °C)	0.1 °C
	L	-200.0 to 900.0 °C	±(0.15 % of rdg + 0.5 °C) Less than 0.0 °C: ±(0.5 % of rdg + 0.5 °C)	±(0.2 % of rdg + 4.0 °C) Less than 0.0 °C: ±(3 % of rdg + 4.0 °C)	0.1 °C
	U	-200.0 to 400.0 °C	±(0.15 % of rdg + 0.5 °C) Less than 0.0 °C: ±(0.7 % of rdg + 0.5 °C)	±(0.2 % of rdg + 2.5 °C) Less than 0.0 °C: ±(3 % of rdg + 2.5 °C)	0.1 °C
	W97Re3-W75Re25	0.0 to 2320.0 °C	±(0.2 % of rdg + 2.5 °C)	±18.0 °C More than 2000.0 °C: ±0.9 % of rdg	0.1 °C
	KpvsAu7Fe	0.0 to 300.0 K	±(0.15 % of rdg + 2.0 K) 0.15 to 280.15K: guaranteed range	±(0.2 % of rdg + 7.0 K) 0.15 to 280.15K: guaranteed range	0.1 K
	Platinel 2	0.0 to 1395.0 °C	±(0.25 % of rdg + 2.3 °C)	±(0.25 % of rdg + 8.0 °C)	0.1 °C
	PR20-40	0.0 to 1900.0 °C	±(0.7 % of rdg + 0.4 °C) However, accuracy at less than 800.0 °C is not guaranteed.	±20.0 °C However, accuracy at less than 800.0 °C is not guaranteed.	0.1 °C
	NiNiMo	0.0 to 1310.0 °C	±(0.25 % of rdg + 0.7 °C)	±(0.5 % of rdg + 5.0 °C)	0.1 °C
W/ WRe26	0.0 to 2320.0 °C	±(0.2 % of rdg + 2.0 °C) However, accuracy at less than 300.0 °C is not guaranteed.	±(0.4 % of rdg + 12.0 °C) However, accuracy at less than 300.0 °C is not guaranteed.	0.1 °C	
N(AWG14)	0.0 to 1300.0 °C	±(0.2 % of rdg + 1.3 °C)	±(0.5 % of rdg + 7.0 °C)	0.1 °C	
XK GOST	-200.0 to 600.0 °C	±(0.25 % of rdg + 0.8 °C)	±(0.5 % of rdg + 4.0 °C)	0.1 °C	

Continued

Input Type		Range	Measurement accuracy (digital display)		Max. resolution of digital display
			A/D integration time: 16.7ms or more	A/D integration time: 1.67ms (fast sampling mode)	
RTD	Pt100	-200.0 to 850.0 °C	±(0.15 % of rdg + 0.3 °C)	±(0.3 % of rdg + 1.5 °C)	0.1 °C
		-150.00 to 150.00 °C			0.01 °C
	JPt100	-200.00 to 550.00 °C	±(0.15 % of rdg + 0.3 °C)	±(0.3 % of rdg + 1.5 °C)	0.1 °C
		-150.00 to 150.00 °C			0.01 °C
	Cu10 GE	-200.0 to 300.0 °C	±(0.2 % of rdg + 2.0 °C) guaranteed range Cu10 GE: -70.0 to 170.0 °C Cu10 L&N: -75.0 to 150.0 °C Cu10 WEED: -200.0 to 260.0 °C Other range: -200.0 to 300.0 °C	±(0.4 % of rdg + 6.0 °C) guaranteed range Cu10 GE: -70.0 to 170.0 °C Cu10 L&N: -75.0 to 150.0 °C Cu10 WEED: -200.0 to 260.0 °C Other range: -200.0 to 300.0 °C	0.1 °C
	Cu10 L&N	-200.0 to 300.0 °C			
	Cu10 WEED	-200.0 to 300.0 °C			
	Cu10 BAILEY	-200.0 to 300.0 °C			
	Cu10 (20 °C) alpha=0.00392	-200.0 to 300.0 °C			
	Cu10 (20 °C) alpha=0.00393	-200.0 to 300.0 °C			
	Cu25 (0 °C) alpha=0.00425	-200.0 to 300.0 °C			±(0.3 % of rdg + 0.8 °C)
	Cu53 (0 °C) alpha=0.00426035	-50.0 to 150.0 °C	±(0.15 % of rdg + 0.8 °C)	±(0.3 % of rdg + 4.0 °C)	0.1 °C
	Cu100 (0 °C) alpha=0.00425	-50.0 to 150.0 °C	±(0.2 % of rdg + 1.0 °C)	±(0.4 % of rdg + 5.0 °C)	0.1 °C
	J263B	0.0 to 300.0 K	±1.0 K Less than 40.0 K: ±3.0 K	±3.0 K Less than 40.0 K: ±9.0 K	0.1 K
	Ni100 (SAMA)	-200.0 to 250.0 °C	±(0.15 % of rdg + 0.4 °C)	±(0.3 % of rdg + 2.0 °C)	0.1 °C
	Ni100 (DIN)	-60.0 to 180.0 °C			
	Ni120	-70.0 to 200.0 °C			
	Pt25	-200.0 to 550.0 °C	±(0.15 % of rdg + 0.8 °C)	±(0.3 % of rdg + 4.0 °C)	0.1 °C
	Pt50	-200.0 to 550.0 °C	±(0.3 % of rdg + 0.6 °C)	±(0.6 % of rdg + 3.0 °C)	0.1 °C
	Pt200 WEED	-100.0 to 250.0 °C	±(0.2 % of rdg + 2.0 °C)	±(0.4 % of rdg + 6.0 °C)	0.1 °C
Cu10 GOST	-200.0 to 200.0 °C				
Cu50 GOST	-200.0 to 200.0 °C	±(0.15 % of rdg + 0.6 °C)	±(0.3 % of rdg + 4.0 °C)	0.1 °C	
Cu100 GOST	-200.0 to 200.0 °C	±(0.15 % of rdg + 0.3 °C)	±(0.3 % of rdg + 1.5 °C)	0.1 °C	
Pt46 GOST	-200.0 to 550.0 °C	±(0.3 % of rdg + 0.8 °C)	±(0.6 % of rdg + 4.0 °C)	0.1 °C	
Pt100 GOST	-200.0 to 600.0 °C	±(0.15 % of rdg + 0.3 °C)	±(0.3 % of rdg + 2.0 °C)	0.1 °C	
DI	Level	Threshold level (V _{th} =2.4 V) Accuracy: ±0.1 V			-
	Contact	Less than 1 kΩ: 1(ON), More than 100 kΩ: 0(OFF) (parallel capacitance of 0.01 μF or less)			-

Measurement accuracy at scaling: measurement accuracy at scaling (digits) = measurement accuracy (digits) x scaling span (digits)/measurement span (digits) + 2 digits

* Rounding up decimal places

- Burnout detection: Burnout upscale, downscale, or OFF selectable (for each channel).
Available input: TC, RTD, Standard signal
TC; Normal: 2 kΩ or less., Burnout: 200 kΩ or more (parallel capacitance of 0.01 μF or less)
Detection current: Approx. 10 μA
RTD; Normal: wiring resistance or less,
Burnout: 200 kΩ or more (parallel capacitance of less than 0.01 μF or less)
Standard signal: Normal: Within measuring range, Burnout: less than 0.1 V
- Input external resistance:
DC voltage, thermocouple input: 2 kΩ or below
Resistance temperature detector input: 10 Ω or below in each wire (Same resistance in three wires)
- Input bias current: ±10 nA or less (when burnout function does not work)
- Measured current (for RTD): Approx. 1 mA
- Input resistance:
10 MΩ or more for TC/DC voltage (1 V range or less) input
Approx. 1 MΩ for DC voltage (2 V range or more)/standard signal input
- Allowable signal source resistance: 2 kΩ or less for TC/DC voltage (1 V range or less) input
- Effect of signal source resistance:
±10 μV/1kΩ or less for TC/DC voltage (1 V range or less) input
±0.15 %/1kΩ or less for DC voltage (2 V range or more)/standard signal input
- Allowable wiring resistance: Max. 10 Ω per line for RTD input (conductor resistance between the three lines shall be equal)
- Effect of wiring resistance: ±0.1°C/10 Ω for RTD input (conductor resistance between the three lines shall be equal)
- Allowable input voltage:
±10 V DC for TC/DC voltage (1 V range or less)/RTD/DI input
±60 V DC for DC voltage (2 V range or more) input

- Noise reduction ratio

Integration time *1	Normal mode	Common mode
1.67 ms	50/60 Hz, no noise reduction	More than 80 dB *2 *4
More than 16.7 ms	More than 40 dB *2 *3	More than 120 dB *2 *4

*1 A frequency discrimination setting is made in the main unit.

*2 A resistance temperature detector range is a converted value of voltage when a measured current flows.

*3 50/60 Hz ± 0.1 %

*4 50/60 Hz ± 0.1%, 500 Ω imbalance, between minus measuring terminal and ground

- Normal mode voltage for TC/ DC voltage (1 V range or less)/DI: 1.2 times or less of rated range
Standard signal 0.4 to 2 V range: 2.4 V
Standard signal 1-5 V range: 6 V
RTD (100 Ω): 50 mV peak
RTD (50 Ω): 50 mV peak
- * 50/60Hz, The peak value including the signal.
- Maximum common mode voltage for measuring input: 30 V ACrms (50/60Hz) or 60 V DC (However, maximum common mode noise voltage for measuring input: 250 V ACrms)
- Maximum voltage between measuring input channels: 30 V ACrms (50/60 Hz) or 60 V DC (maximum common mode noise voltage for measuring input: 250 V ACrms)
- Reference junction compensation accuracy: When measuring temperature greater than or equal to 0 °C and when input terminal temperature is balanced
Type K, E, J, T, N, XK GOST: ±0.5 °C (23 °C ± 2 °C), ±0.7 °C (0 to 50 °C), ±1.0 °C (-20 to 60 °C)
Type R, S, W, L, U, W97Re3-W75Re25, Platine12, NiNiMo, W/WRe26, N(AWG14): ±1.0 °C (23 °C ± 2 °C), ±1.4 °C (0 to 50 °C), ±2.0 °C (-20 to 60 °C)
Type KpvsAu7Fe: ±1.4 °C (0 to 7 °C), ±2.0 K (less than 0 °C)
Type B, PR20-40: Internal reference compensation is fixed to 0°C
- Sampling interval/A/D integration time: 10 ch. mode

Sampling interval	Integration time
100 ms/200 ms	1.67 ms
500 ms/1 s	16.7 ms/20 ms/36.7 ms
2 s/5 s	16.7 ms/20 ms/36.7 ms/100 ms

2 ch. mode

Sampling interval	Integration time
100 ms/200 ms/500 ms	16.7 ms/20 ms
1 s	16.7 ms/20 ms/36.7 ms
2 s/5 s	16.7 ms/20 ms/36.7 ms/100 ms

* In 10ch mode, when the scan interval is set to 100 ms or 200 ms, the A/D integration time is fixed at 1.67 ms. This prevents power frequency noise from being eliminated, causing measured values to wobble.

- Calibration correction:
Mode: Linearizer Approximation, Linearizer Bias
Number of set points: 12

- Terminal type: M3 screw terminal or Clamp terminal
- Withstand voltage
Between the input circuits and the internal circuit: 3000 V AC for one minute
Between the analog input channels: 1000 V AC for one minute (excluding b-terminal)
- Insulation resistance:
Between the input terminal and the internal circuit: 20 MΩ or greater at 500 VDC

Safety and EMC Standards

- CSA: CSA22.2 No.61010-1, installation category II (*1), pollution degree 2 (*2), and CSA-C22.2 NO. 61010-2-030-12
- UL: UL61010-1, UL 61010-2-030 (CSA NRTL/C)
- CE:
EMC directive
EN61326-1 compliance, Class A Table 2
EN61000-3-2 compliance
EN61000-3-3 compliance
EN55011 Class A Group 1
Low voltage directive
EN61010-1, EN 61010-2-030
Installation category II (*1)
Pollution degree 2 (*2)
Measurement category II (*3)
- Maximum input voltage for measuring input: ± 60 V DC
- Maximum common mode noise voltage for measuring input: 30 V ACrms 50/60 Hz or 60 V DC (However, maximum common mode noise voltage for measuring input: 250 V AC)
- C-Tick: EN55011 compliance, Class A Group 1
- KC marking: Electromagnetic wave interference prevention standard, electromagnetic wave protection standard compliance
- *1 Installation category (overvoltage category) II:
Describes a number which defines a transient overvoltage condition.
Implies the regulation for impulse withstand voltage. "II" applies to electrical equipment which is supplied from the fixed installation like a distribution board.
- *2 Pollution degree 2:
Describes the degree to which a solid, liquid, or gas which deteriorates dielectric strength or surface resistivity is adhering.
"2" applies to normal indoor atmosphere.
Normally, only non-conductive pollution occurs.
- *3 Measurement category II:
Applies to measuring circuits connected to low voltage installation, and electrical instruments supplied with power from fixed equipment such as electric switchboards.
- WEEE Directive: Compliant

Construction

- Front panel (terminal): Water and dust-proof, Complies with IEC529-IP20
- Material: Polycarbonate
- Color;
Front: Charcoal grey light (CC28)
Bezel: Smoke blue (CC53)
- Dimensions: 45 mm(W) x 100 mm(H) x 133 mm(D) (D: including terminal cover)
- Weight: Approx. 0.3 kg

Power Supply

- Supply from GP main unit.
- Power consumption: 0.7W or less

Isolation

Analog input CH1	Input circuit	Internal circuit
Analog input CH2		
Analog input CH3		
Analog input CH4		
Analog input CH5		
Analog input CH6		
Analog input CH7		
Analog input CH8		
Analog input CH9		
Analog input CH10		

———— Functional insulation
 ===== Reinforced insulation

Terminal arrangements

M3 screw terminal

No.	Symbol	No.	Symbol	No.	Symbol
301	CH1(/b)	201	CH1(-/B)	101	CH1(+/A)
302	CH2(/b)	202	CH2(-/B)	102	CH2(+/A)
303	CH3(/b)	203	CH3(-/B)	103	CH3(+/A)
304	CH4(/b)	204	CH4(-/B)	104	CH4(+/A)
305	CH5(/b)	205	CH5(-/B)	105	CH5(+/A)
306	CH6(/b)	206	CH6(-/B)	106	CH6(+/A)
307	CH7(/b)	207	CH7(-/B)	107	CH7(+/A)
308	CH8(/b)	208	CH8(-/B)	108	CH8(+/A)
309	CH9(/b)	209	CH9(-/B)	109	CH9(+/A)
310	CH10(/b)	210	CH10(-/B)	110	CH10(+/A)

* RTD input terminal b is shorted internally across all channels.

Clamp terminal

No.	Symbol	No.	Symbol
201	CH2(+/A)	101	CH1(+/A)
202	CH2(-/B)	102	CH1(-/B)
203	CH2(/b)	103	CH1(/b)
204	CH4(+/A)	104	CH3(+/A)
205	CH4(-/B)	105	CH3(-/B)
206	CH4(/b)	106	CH3(/b)
207	CH6(+/A)	107	CH5(+/A)
208	CH6(-/B)	108	CH5(-/B)
209	CH6(/b)	109	CH5(/b)
210	CH8(+/A)	110	CH7(+/A)
211	CH8(-/B)	111	CH7(-/B)
212	CH8(/b)	112	CH7(/b)
213	CH10(+/A)	113	CH9(+/A)
214	CH10(-/B)	114	CH9(-/B)
215	CH10(/b)	115	CH9(/b)

* RTD input terminal b is shorted internally across all channels.

A/D Calibration Value

Two types of A/D calibration values (factory shipment setting and user setting) can be saved. If the user setting is not proper, it can be restored to the calibration value at factory shipment.

External Dimensions

M3 screw terminal

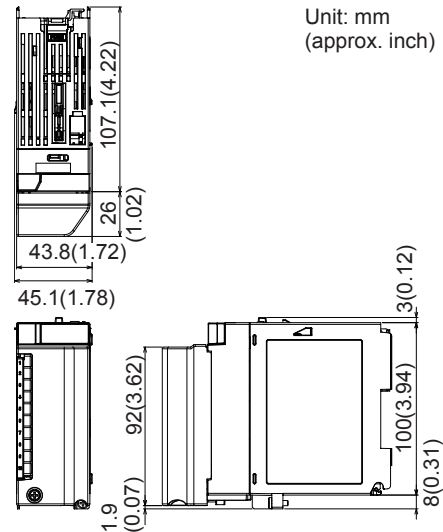

Clamp terminal

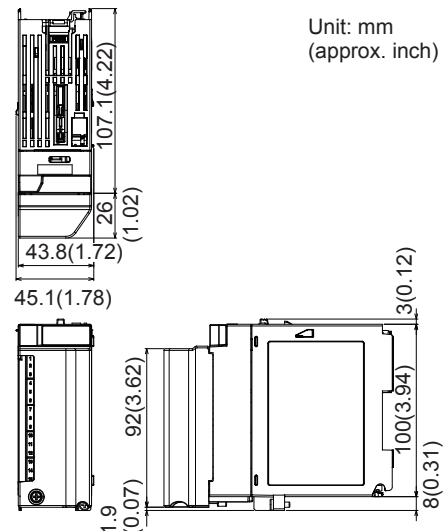

Normal Operating Conditions

Same as the GP main unit

Transport and Storage Conditions

Same as the GP main unit

Effects of Operating Conditions

- Influence of ambient temperature: variation against a change of 10 °C at an accumulation time of 16.67 ms or more ± (0.05% of rdg + 0.05%) or below KpvsAu7Fe, PR20-40: ±(0.05% of rdg + 0.1%) or below, Cu10Ω: ±(0.2% of rdg + 0.1 °C) or below No reference contact accuracy is guaranteed. Measurement accuracy at an ambient temperature of 7 °C or higher is not guaranteed in KpvsAu7Fe.
- Influence of power supply voltage variation: Accuracy is satisfied in the range of rated power supply voltage.
- Influence of external magnetic field: Variations against an AC external magnetic field (50/60 Hz, 400 A/m) are ±(0.1% of rdg+ 0.1%) or below.

DIGITAL INPUT MODULE (Model GX90XD or Options /CRx1)



GX90XD

- Application: Remote control input, etc
- Number of inputs: 16
- Measurement interval: 100 ms (shortest)
- Input type: Open collector or Voltage-free contact
- Insulation type: Photocoupler, Trance (power supply)
- Contact rating: 12 V DC, 20 mA or more
- Input resistance: Approx. 1 kΩ
- Allowable input voltage: 10 V
- ON/OFF detection
 - Open collector contact input:
 - Voltage in ON state: 0.5 V DC or less
 - Leakage current in OFF state: 0.5 mA or less
 - Voltage-free contact input:
 - Contact resistance in ON state: 200 Ω or less
 - Contact resistance in OFF state: 50 kΩ or more
- Number of common: 2 (1 point/8 channels)
- Terminal type: M3 screw terminal or Clamp terminal
(In case of Options /CRx1, a digital input module has M3 screw terminals.)
- Withstand voltage
 - Between the input terminals and the internal circuit: 1500 V AC for one minute
- Insulation resistance:
 - Between the input terminals and the internal circuit: 20 MΩ or greater at 500 VDC

Safety and EMC Standards

- CSA: CSA22.2 No.61010-1, installation category II (*1), pollution degree 2 (*2), and CSA-C22.2 NO. 61010-2-030-12
- UL: UL61010-1 (CSA NRTL/C)
- CE:
 - EMC directive
 - EN61326-1 compliance, Class A Table 2
 - EN61000-3-2 compliance
 - EN61000-3-3 compliance
 - EN55011 Class A Group 1
 - Low voltage directive
 - EN61010-1
 - Installation category II (*1)
 - Pollution degree 2 (*2)
 - Not included in the measurement category
- C-Tick: EN55011 compliance, Class A Group 1
- KC marking: Electromagnetic wave interference prevention standard, electromagnetic wave protection standard compliance

- *1 Installation category (overvoltage category) II: Describes a number which defines a transient overvoltage condition. Implies the regulation for impulse withstand voltage. "II" applies to electrical equipment which is supplied from the fixed installation like a distribution board.
- *2 Pollution degree 2: Describes the degree to which a solid, liquid, or gas which deteriorates dielectric strength or surface resistivity is adhering. "2" applies to normal indoor atmosphere. Normally, only non-conductive pollution occurs.
- WEEE Directive: Compliant

Construction

- Front panel (terminal): Water and dust-proof, Complies with IEC529-IP20
- Material: Polycarbonate
- Color;
 - Front: Charcoal grey light (CC28)
 - Bezel: Smoke blue (CC53)
- Dimensions: 45 mm(W) x 100 mm(H) x 133 mm(D) (D: including terminal cover)
- Weight: Approx. 0.3 kg

Power Supply

- Supply from GP main unit.
 - Power consumption: 0.7W or less

Terminal arrangements

M3 screw terminal/Clamp terminal

No.	Symbol	No.	Symbol
21	DI9	11	DI1
22	DI10	12	DI2
23	DI11	13	DI3
24	DI12	14	DI4
25	DI13	15	DI5
26	DI14	16	DI6
27	DI15	17	DI7
28	DI16	18	DI8
29	COM	19	COM
30	-	20	-

External Dimensions

M3 screw terminal

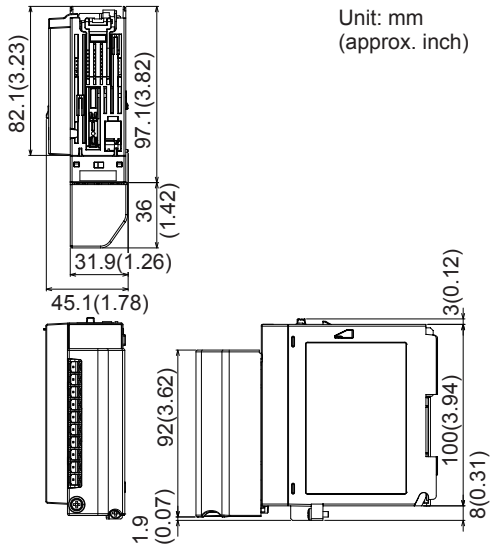

Clamp terminal

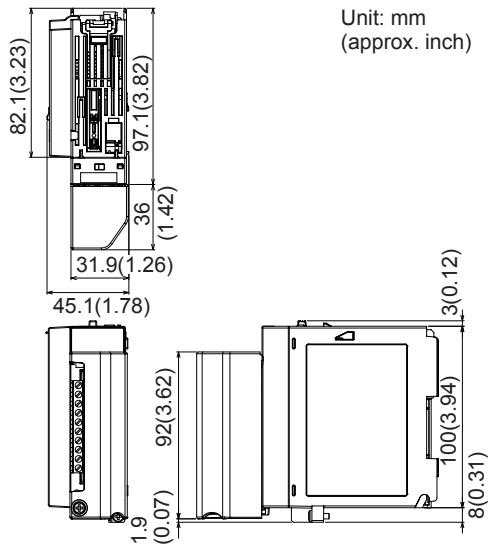

Normal Operating Conditions

Same as the GP main unit

Transport and Storage Conditions

Same as the GP main unit

DIGITAL OUTPUT MODULE (Model GX90YD, or Options /CR1x, /CR2x, /CR4x)



GX90YD

- Application: Alarm output, etc
- Number of outputs: 6
- Output update interval: 100 ms (shortest)
- Output type: Relay contact output, SPDT (NO-C-NC)
- Insulation type: Mechanical
- Rated load voltage: 24 V DC or 250 V AC or less
- Rated load current: 3 A (DC)/3 A (AC), resistance load, each channel
- Min. load voltage/current: 5 V DC
- Recommended replacement periods of contact: Mechanical 5,000,000 more ON-OFF operations
Electrical 30,000 more ON-OFF operations (250 V AC 3 A or 24 V DC 3 A, resistance load)
- Number of common: 6
- Power supply: Not necessary
- Terminal type: M3 screw terminal
- Withstand voltage
Between the output terminals and the internal circuit: 3000 V AC for one minute
- Insulation resistance:
Between the output terminals and the internal circuit: 20 MΩ or greater at 500 VDC

Safety and EMC Standards

- Safety and EMC Standards: Same as the digital input module
- WEEE Directive: Compliant

Construction

- Front panel (terminal): Water and dust-proof, Complies with IEC529-IP20
- Material: Polycarbonate
- Color;
Front: Charcoal grey light (CC28)
Bezel: Smoke blue (CC53)
- Dimensions: 45 mm(W) x 100 mm(H) x 133 mm(D) (D: including terminal cover)
- Weight: Approx. 0.3 kg

Power Supply

- Supply from GP main unit.
- Power consumption: 1.4 W or less

Terminal arrangements

M3 screw terminal

No.	Symbol	No.	Symbol
21	DO4 N.C.	11	DO1 N.C.
22	DO4 COM	12	DO1 COM
23	DO4 N.O.	13	DO1 N.O.
24	DO5 N.C.	14	DO2 N.C.
25	DO5 COM	15	DO2 COM
26	DO5 N.O.	16	DO2 N.O.
27	DO6 N.C.	17	DO3 N.C.
28	DO6 COM	18	DO3 COM
29	DO6 N.O.	19	DO3 N.O.
30	-	20	-

External Dimensions

M3 screw terminal

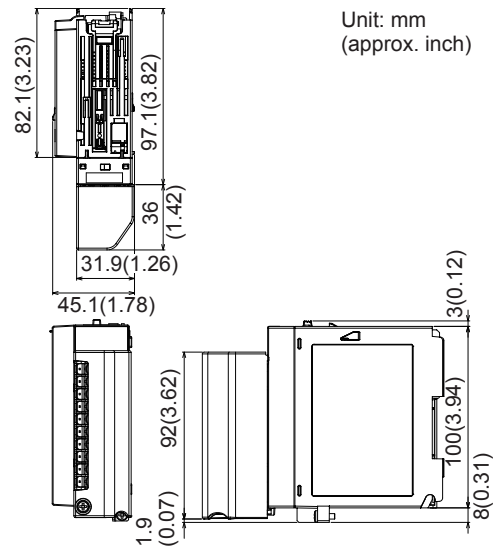

APPLICATION SOFTWARE

SMARTDAC+ STANDARD

- Universal viewer
- Web application/Hardware configurator

Download the latest version of the software from the following URL;

www.smartdacplus.com/software/en/

Operating environment

OS:

OS	Type
Windows XP	Home Edition SP3 (Except for Professional x64 Edition)
	Professional SP3 (Except for Professional x64 Edition)
Windows Vista	Home Premium SP2 (Except for 64-bits Editions)
	Business SP2 (Except for 64-bits Editions)
Windows 7	Home Premium SP1 (32-bit and 64-bit Editions)
	Professional SP1 (32-bit and 64-bit Editions)

Processor and main memory:

OS	Processor and main memory
Windows XP	Intel Pentium 4, 3GHz or faster x64 or x86, 2GB or more
Windows Vista	
Windows 7	32-bit edition Intel Pentium 4, 3GHz or faster x64 or x86, 2GB or more 64-bit edition Intel x64 processor that is equivalent to Intel Pentium 4, 3 GHz or faster, 2GB or more

Browser:

Browser	Version
Windows Internet Explorer Java Runtime Environment 1.6 (Version 6)	Internet Explorer 6, Internet Explorer 8 or Internet Explorer 9

Hard disk:

- 100MB or more of free space

Display:

- A video card that is recommended for the OS and a display that is supported by the OS, has a resolution of 1024 x 768 or higher, and that can show 65,536 colors (16-bit, high color) or more.

Universal Viewer software

The universal viewer can display the following data generated by the recorder on the screen and print it out on the printer.

- Display data file
- Event data file
- Report data file (Including Hour, Day, Week Month)
- Manual sample data file

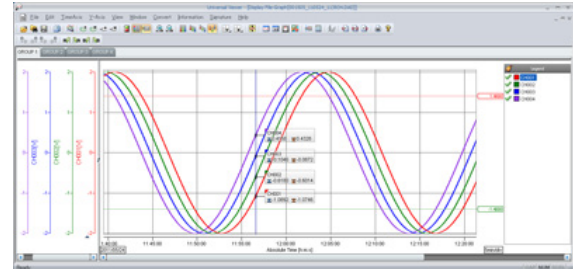

- Viewer function
Waveform display, digital display, circular display, list display, report display, operation log display etc.
- Data conversion:
File conversion to ASCII or MS-Excel format

Web application/Hardware configurator

- Online setting on Web browser (IE)
- Offline setting on Web browser (IE)

Both settings can be made using browsers such as Internet Explorer 6, Internet Explorer 8 and Internet Explorer 9.

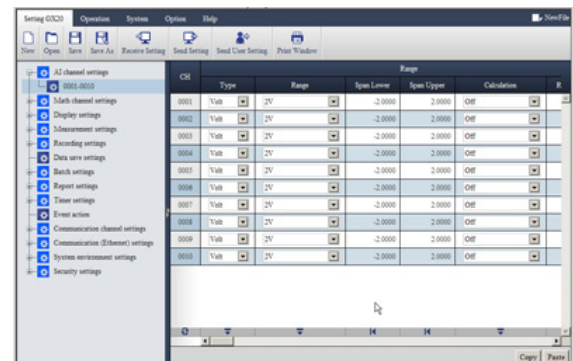

■ MODEL AND SUFFIX CODES

Model	Suffix Code			Optional code	Description
GP10					Paperless recorder (Portable type, Small display)
GP20					Paperless recorder (Portable type, Large display)
Type	-1				Standard
Display language	E				English, degF, DST (summer/winter time) *9
Power supply		1			100 V AC, 240 V AC
Power cord			D		Power cord UL/CSA standard
			F		Power cord VDE standard
			R		Power cord AS standard
			Q		Power cord BS standard
			H		Power cord GB standard
			N		Power cord NBR standard
Optional features			/C2		RS-232 *1
			/C3		RS-422/485 *1
			/D5		VGA output *2
			/FL		Fail output, 1 point
			/MT		Mathematical function (with report function)
			/MC		Communication channel function
			/UH		USB interface (Host 2 ports)

Analog input module, Digital I/O module:

Please add the following suffix codes to the main unit model and specification codes.

Option	Optional code	Description
Optional features (Analog input) *3	/UC10	With analog input module, 10ch (Clamp terminal)
	/UC20	With analog input module, 20ch (Clamp terminal) *6
	/UC30	With analog input module, 30ch (Clamp terminal) *7
	/UC40	With analog input module, 40ch (Clamp terminal) *4
	/UC50	With analog input module, 50ch (Clamp terminal) *4
	/US10	With analog input module, 10ch (M3 screw terminal)
	/US20	With analog input module, 20ch (M3 screw terminal) *6
	/US30	With analog input module, 30ch (M3 screw terminal) *7
	/US40	With analog input module, 40ch (M3 screw terminal) *4
	/US50	With analog input module, 50ch (M3 screw terminal) *4
Optional features (Digital I/O) *3	/CR01	With digital I/O module, (Output:0, Input:16) *7 *8
	/CR10	With digital I/O module, (Output:6, Input:0) *7
	/CR11	With digital I/O module, (Output:6, Input:16) *6 *7 *8
	/CR20	With digital I/O module, (Output:12, Input:0) *5
	/CR21	With digital I/O module, (Output:12, Input:16) *5 *8
	/CR40	With digital I/O module, (Output:24, Input:0) *5
	/CR41	With digital I/O module, (Output:24, Input:16) *5 *8

*1 /C2 and /C3 cannot be specified together.

*2 /D5 can be specified only for the GP20.

*3 Only one option can be specified.

*4 /UC40, /UC50, /US40 and /US50 cannot be specified for the GP10.

*5 /CR20, /CR21, /CR40 and /CR41 cannot be specified for the GP10.

*6 If /UC20 or /US20 is specified, /CR11 cannot be specified for the GP10.

*7 If /UC30 or /US30 is specified, /CR01, /CR10 and /CR11 cannot be specified for the GP10.

*8 A digital input module has M3 screw terminals.

*9 The Display language is selectable from English, German, French, Russian, Korean, Chinese, Japanese. (As of Mar., 2013)
To confirm the current available languages, please visit the following website.

URL: <http://www.yokogawa.com/ns/language/>

Analog input module, Digital I/O module (sold separately):

MODEL and SUFFIX Code (GX90XA)

Model	Suffix Code				Description
GX90XA					Analog Input Module for GX/GP series
Number of channels	-10				10 channels
Type	-U2				Universal, Scanner type (3-wire RTD b-terminal common)
-		N			Always N
Terminal form			-3		Screw terminal (M3)
			-C		Clamp terminal
Area				N	General

MODEL and SUFFIX Code (GX90XD)

Model	Suffix Code				Description
GX90XD					Digital Input Module for GX/GP series
Number of channels	-16				16 channels
Type	-11				Open collector/Non-voltage, contact (shared common), Rated 5 VDC
-		N			Always N
Terminal form			-3		Screw terminal (M3)
			-C		Clamp terminal
Area				N	General

MODEL and SUFFIX Code (GX90YD)

Model	Suffix Code				Description
GX90YD					Digital Output Module for GX/GP series
Number of channels	-06				6 channels
Type	-11				Relay, SPDT(NO-C-NC)
-		N			Always N
Terminal form			-3		Screw terminal (M3)
Area				N	General

■ Standard Accessories

Product	Qty
SD memory card (1GB)	1
Stylus pen (touch pen)	1
Tag sheet (for GP10 or GP20)	1
Sheet (paper) (for GP10 or GP20)	1

■ Optional Accessories (Sold Separately)

Product	Model/part no.
Model SD memory card (1GB)	773001
Stylus pen (touch pen)	B8740BZ
Shunt resistor for M3 terminal (10 Ω ± 0.1 %)	X010-010-3
Shunt resistor for M3 terminal (100 Ω ± 0.1 %)	X010-100-3
Shunt resistor for M3 terminal (250 Ω ± 0.1 %)	X010-250-3
Shunt resistor for Clamp terminal (10 Ω ± 0.1 %)	438922
Shunt resistor for Clamp terminal (100 Ω ± 0.1 %)	438921
Shunt resistor for Clamp terminal (250 Ω ± 0.1 %)	438920

Calibration certificate (sold separately)

When ordering the GP10/GP20 with options (analog input), the calibration certificate for the modules is included in and shipped with the calibration certificate of the main unit. When ordering an analog input module separately, each module gets its own calibration certificate (one certificate per module).

Test certificate (QIC, sold separately)

When ordering the GP10/GP20 with options (analog/digital I/O), the QIC for each module is included in and shipped with the QIC of the main unit. When ordering analog input modules and digital I/O modules separately, each module gets its own QIC (one QIC per module).

User's Manual

Product user's manuals can be downloaded or viewed at the following URL. To view the user's manual, you need to use Adobe Reader 7 or later by Adobe Systems.

URL: www.smartdacplus.com/manual/en/

Product Purchase Specifications

The GP10/GP20 is composed of the main unit and I/O modules.

There are two ways to purchase I/O modules.

One way is to purchase them individually by specifying models GX90XA, GX90XD, and GX90YD.

The other way is to purchase them as an option (/UCxx or /USxx). Purchasing them as an option is convenient, but this places limitations on the number of analog inputs that you can obtain.

If you want to use more than 50 channels, please purchase the I/O modules individually.

Trademarks

The TCP/IP software used in this product and the document for that TCP/IP software are based in part on BSD networking software, Release 1 licensed from The Regents of the University of California.

- SMARTDAC+ is a trademark of Yokogawa Electric Corporation.
- Microsoft, MS and Windows are registered trademarks of Microsoft Corporation USA.
- Pentium are registered trademarks of Intel Corporation.
- Ethernet is a registered trademark of XEROX Corporation.
- Modbus is a registered trademark of AEG Schneider.
- Kerberos is a trademark of MIT.
- Java and Java-related trademarks are trademarks or registered trademarks of Sun Microsystems, Inc. in the United States and/or other countries.
- Other company and/or product names are registered trade mark of their manufactures.