



## ET35

### Tracked Conventional Tail Excavators



#### Convincing productivity

The 3.5-ton class tracked excavator convinces with many sophisticated details. Features such as good stability or the new, ergonomically designed cabin ensure efficient and fatigue-free working. Due to the numerous factory-installed options, the ET35 can also be individually adapted to the customers needs.



#### Performance meets maximum efficiency

- Optimized engine-pump management for up to 15% faster work cycles.
- Hydraulically piloted accelerator pedals for a precise control of the driving function with the feet leaving hands free.



### Intuitive operating concept

Easy and comprehensive control of the excavator thanks to ergonomically designed joystick, jog dial, key pad and 3.5 inch display. The well-known Jog-dial system from the automotive sector allows an intuitive selection of the appropriate operating mode via turn-push button:

- **ECO mode** - the standard mode for efficient and fuel-saving work.
- **Power mode** - maximum pump performance for fast and powerful work.



### Comfort cabin

- High comfort and fatigue-free working thanks to large cabin with plenty of head- and legroom.
- With seat and armrest adjustment, numerous storage compartments, a mobile phone docking station and USB port, the cabin can be individually adjusted to the preferences of the driver.
- Sliding side windows for optimum all-round visibility and air circulation in the cabin.



### **Windscreen mechanism with many functions**

The windscreens of the EZ36 can be adapted to the conditions on the construction site:

- Closed windscreen: ideal protection no matter what the weather.
- Open windscreen: easy ventilation of the cabin and unrestricted communication with colleagues.
- Both windscreens can be stored under the cabin roof - so they do not get lost.



### **Individually configurable**

The customer has further options available ex factory, which are installed individually as required.

- Up to 5 additional control circuits
- Telematic
- Additional rear weight
- Rubber or steel tracks

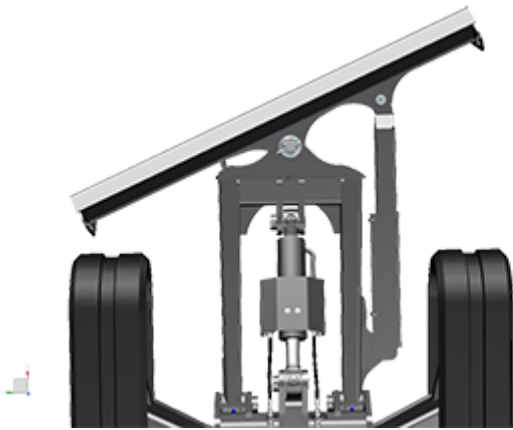

### **Swiveling dozer blade**

The swiveling dozer blade with floating position consistently exerts force to the cutting edge. So the position of the shield needs to be adjusted less often, which makes the workflow more efficient and saves time. (Not combinable with the option VDS).

---



### **Innovative system for all grapple work**

Ideal for all grappling work is the optional "hydraulic thumb", a hydraulic clamp on the bucket.

---



### **Working in the slope - without coming to falter**

The stepless adjustable inclination VDS compensates slopes of up to 27% and makes vertical digging on slopes possible and easier, which not only provides better ergonomic conditions for the driver, but also saves time and excavation.

---

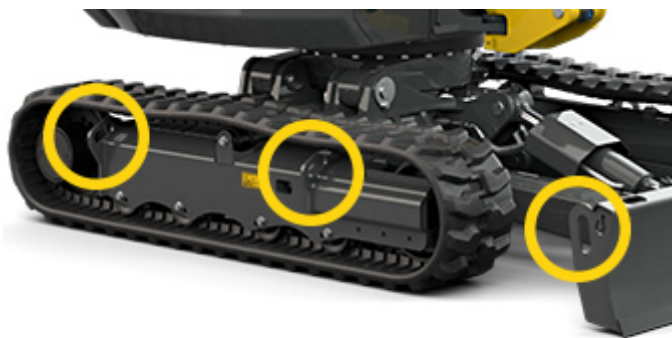

### **Transporting made easy**

Easy and safe transport thanks to 6 large lashing eyes on the chassis frame and 2 on the dozer blade.

---



### **Lifting loads**

The external rollers provide increased smoothness of the chains and additional lateral stability for lifting heavy loads.



### Unrestricted maintenance and service access

- Tipping and dismountable cabin facilitates inspections, maintenance and repair work.
- Service-related components can be accessed quick and easy due to the removable covers and the large side hood.
- Lower operating costs due to two low-consumption engine variants that do not require exhaust aftertreatment.



### Game Free boom system - even after many operations

Heavy-duty bolts and bearings are equipped with bushings that can be exchanged easily. The boom system thus works trouble-free even in the long term.

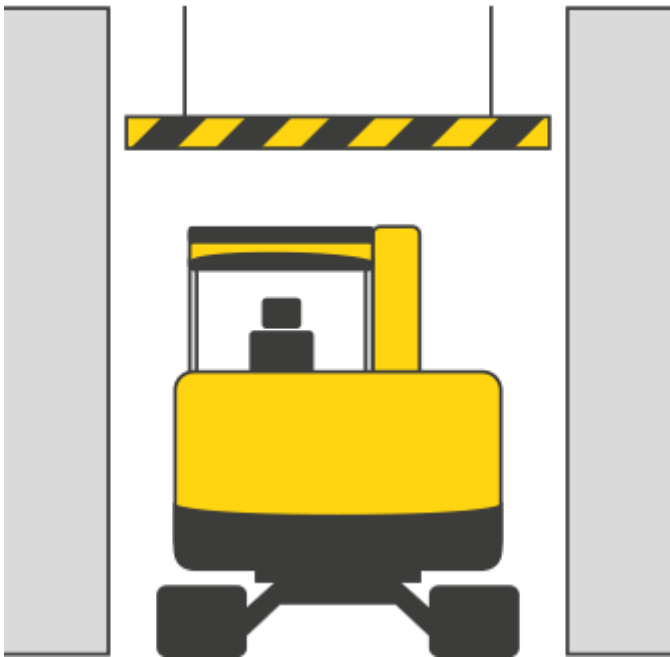

**Compact dimensions meet intelligent design:**

- Long service life thanks to robust and proven design.
  - Robust frame with sloping chassis reduce dirt accumulation and facilitate the cleaning of the machine.
  - Compact dimensions facilitate work in confined areas and increase the range of applications of the machine.
-



## Technical specifications

	ET35 - level III / Tier IVi	ET35 - Tier IV final
<b>Operating data</b>		
Shipping weight min. kg	3,260	3,260
Operating weight kg	3,450 - 4,361	3,450 - 4,361
Biting force max. kN	21.1	21.1
Breakout force max. kN	35	35
Digging depth max. (long dipper stick) mm	3,497	3,497
Dumping height mm	3337 - 3489	3337 - 3489
Digging radius max. (long dipper stick) mm	5,507	5,507
Superstructure slewing speed 1/min	9.5	9.5
L x W x H mm	5268 x 1630 x 2491	5268 x 1630 x 2491
<b>Engine / Motor</b>		
Engine / Motor manufacturer	Yanmar Diesel engine	Yanmar Diesel engine
Engine / Motor type	3TNV88-BPWN	3TNV88F-EPWN
Engine / Motor	Water-cooled 3-cylinder suction engine	Water-cooled 3-cylinder suction engine
Displacement cm <sup>3</sup>	1,642	1,642
RPM / speed rpm	2,500	2,430
Engine performance POWER mode kW	22.2	18.2
Engine performance ECO mode kW		17.8
Battery Ah	71	71
Fuel tank capacity l	44	44
Voltage V	12	12
Input current A	71	71
<b>Hydraulic system suppressing control</b>		
Duty pump	2 axial piston pumps / 2 gear pumps	2 axial piston pumps / 2 gear pumps
Flow rate l/min	120.1	116.6
Operating pressure for working and traction hydraulics bar	240	240
Operating pressure slewing gear bar	195	195
RPM / speed superstructure rpm	9.5	9.5
<b>Undercarriage</b>		
Travel speed max. km/h	4.7	4.7





	ET35 - level III / Tier IVi	ET35 - Tier IV final
Chain width mm	300	300
Ground clearance mm	251	251
<b>Dozer Blade</b>		
Width mm	1,630	1,630
Height mm	357	357
Stroke dozer blade above ground mm	392	392
Stroke dozer blade below ground mm	505	505



## Dimensions

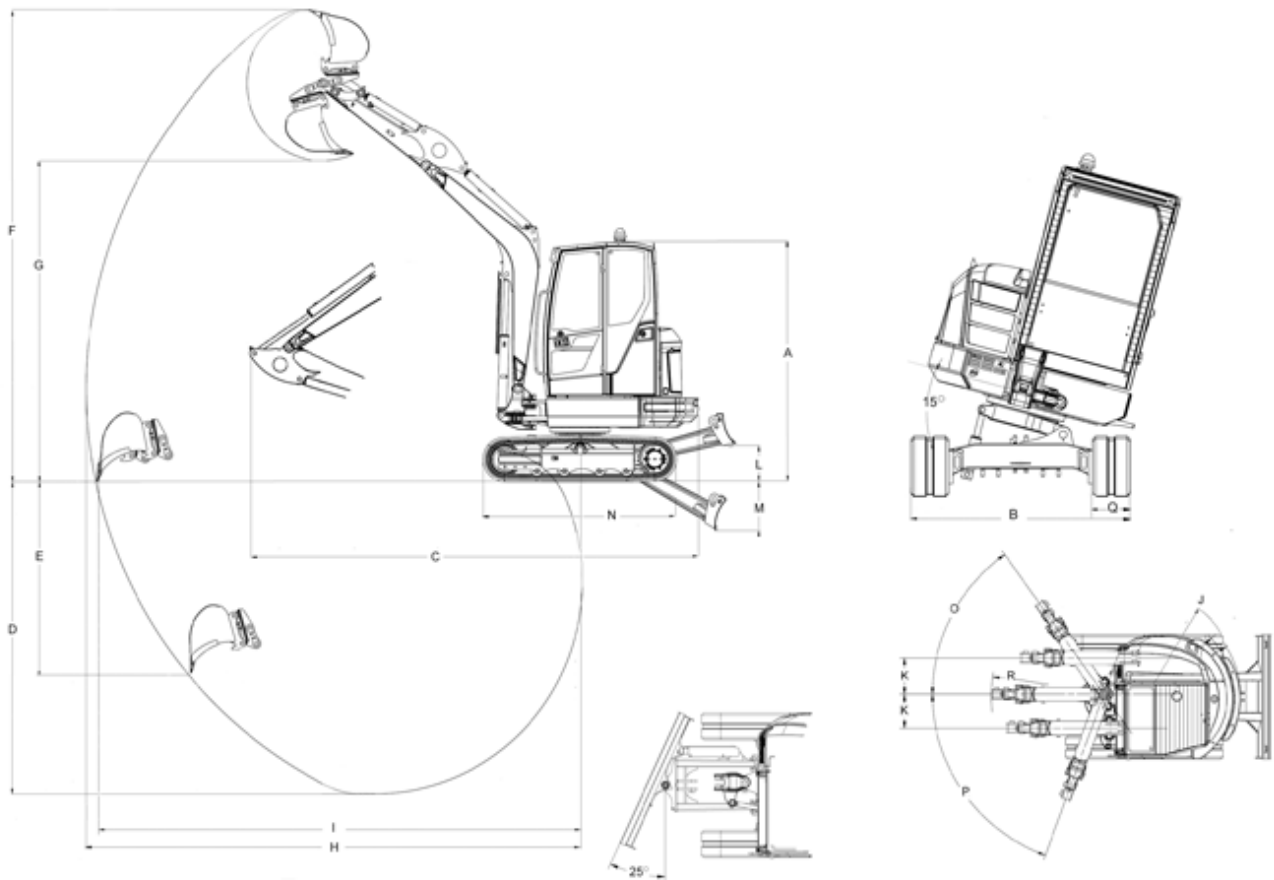

with option VDS

A	Height	2,491 mm	2,573 mm
B	Width	1,630 mm	1,630 mm
Q	Width undercarriage	300 mm	300 mm
C	Transport length (short DS)	5,268 mm	5,252 mm
D	Digging depth max. (short DS)	3,245 mm	3,166 mm
D	Digging depth max. (long DS)	3,497 mm	3,416 mm
E	Insertion depth max. vertical (short DS)	2,120 mm	2,042 mm
E	Insertion depth max. vertical (long DS)	2,360 mm	2,279 mm
F	Insertion height max. (short DS)	4,929 mm	5,010 mm



F	Insertion height max. (long DS)	5,082 mm	5,163 mm
G	Dump height max. (short DS)	3,337 mm	3,417 mm
G	Dump height max. (long DS)	3,489 mm	3,570 mm
H	Digging radius max. (short DS)	5,270 mm	5,270 mm
H	Digging radius max. (long DS)	5,507 mm	5,507 mm
I	Range on the ground max. (short DS)	5,158 mm	5,143 mm
I	Range on the ground max. (long DS)	5,408 mm	5,393 mm
J	Rear swivel radius	1,168 mm	1,168 mm
K	Arm displacement max. to center bucket right	476 mm	476 mm
K	Arm displacement max. to center bucket right	447 mm	447 mm
L	Lift height max. dozer blade above ground	393 mm	393 mm
M	Scraping depth max. dozer blade below ground	505 mm	505 mm
N	Length undercarriage	2,062 mm	2,062 mm
O	Turning angle max. boom to the right	55 °	55 °
P	Turning angle boom to the left	70 °	70 °

DS = dipper stick

**Please note**

that product availability can vary from country to country. It is possible that information / products may not be available in your country. More detailed information on engine power can be found in the operator's manual; the stated power may vary due to specific operating conditions.

Subject to alterations and errors excepted. Applicable also to illustrations.

Copyright © 2018 Wacker Neuson SE.