

BANDEROLEUSE SEMI AUTOMATIQUE A BRAS TOURNANT MODELE P17

Le cycle de banderolage est effectué au moyen du bras tournant supportant le chariot porte-bobine et qui tourne autour de la palette.

Dimensions maxi. Palette et ou Roll :

800 X 1200 X 2400 H mm (palette incluse)

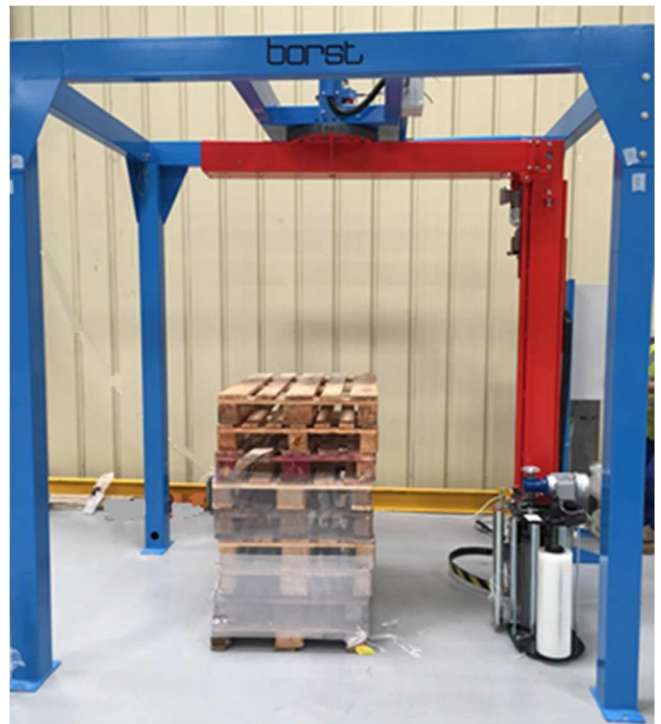

Fonctionnement

- 1- L'opérateur positionne le Roll et/ou la palette à l'intérieur de la machine.
- 2- L'opérateur accroche le film à la base de la charge et, après avoir sélectionné le cycle de banderolage, déclenche le système en appuyant sur le bouton poussoir "START".
- 3- En fin de cycle, le bras tournant s'arrête dans la même position de départ et l'opérateur coupe le film.

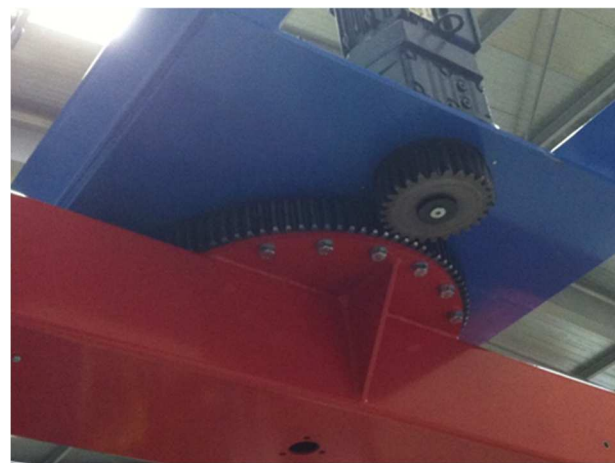

verrouillés par code

PACKSILVER 501 chemin de l'église 01600 Misérieux



www.packsilver.fr



06 52 37 69 06
04 27 11 75 47



jdoizy@packsilver.fr

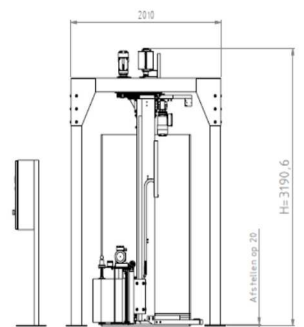
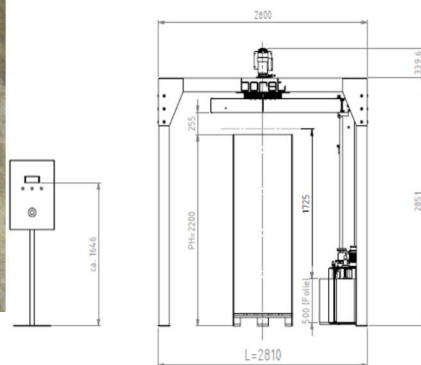
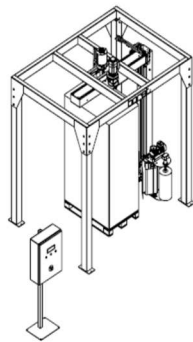
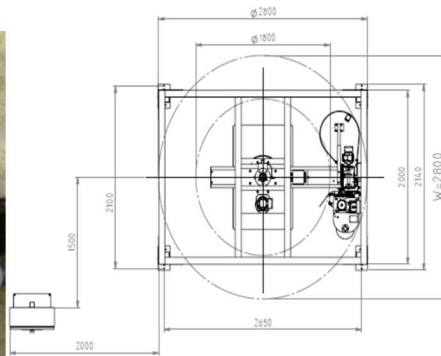
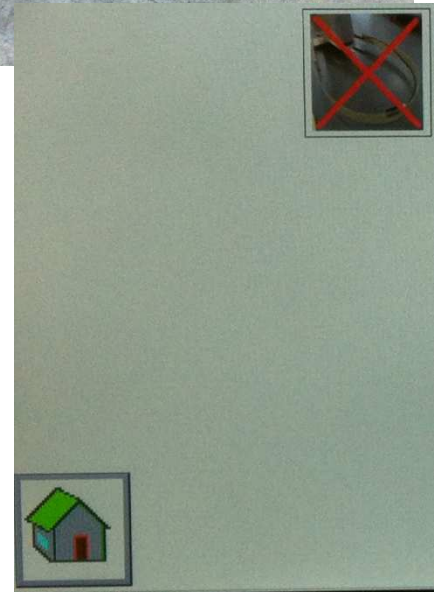

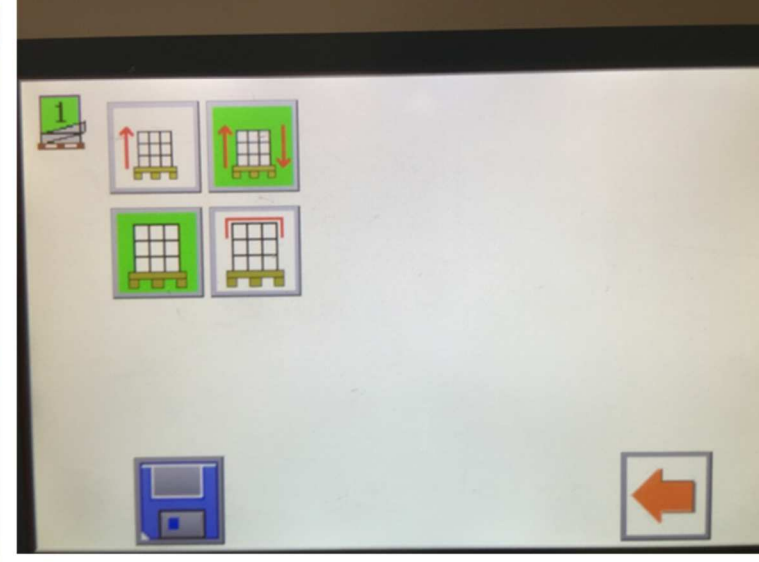
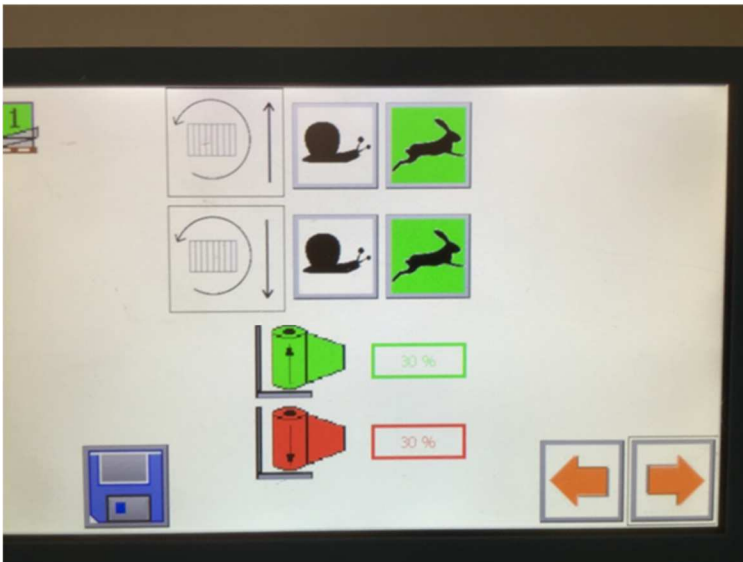
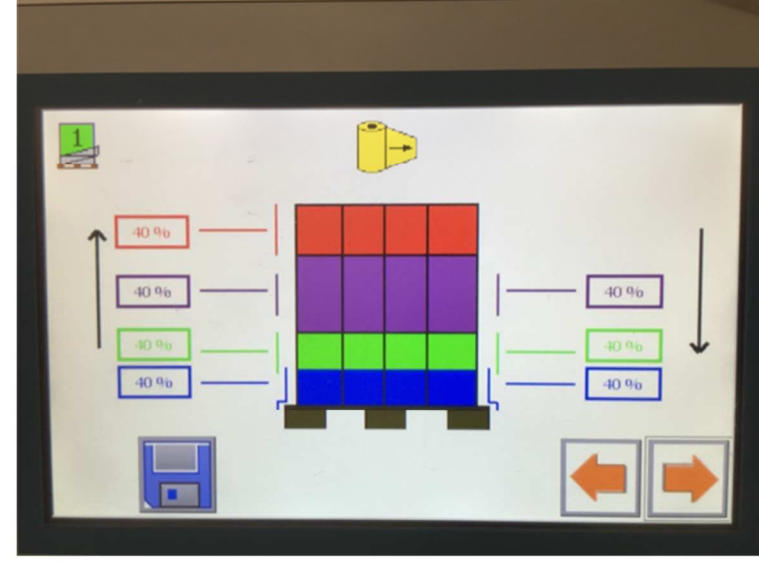
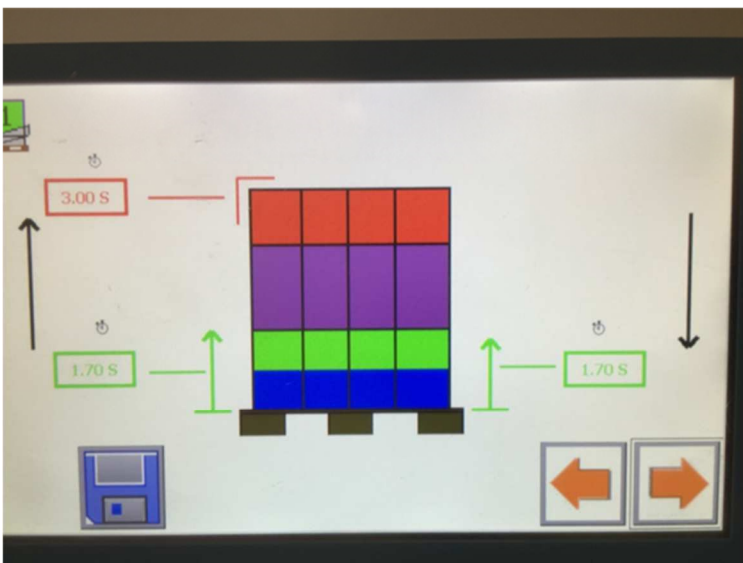
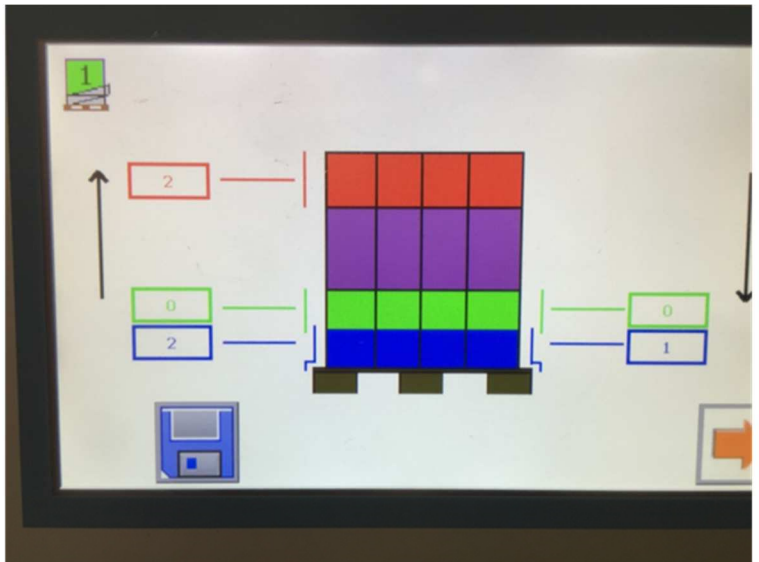
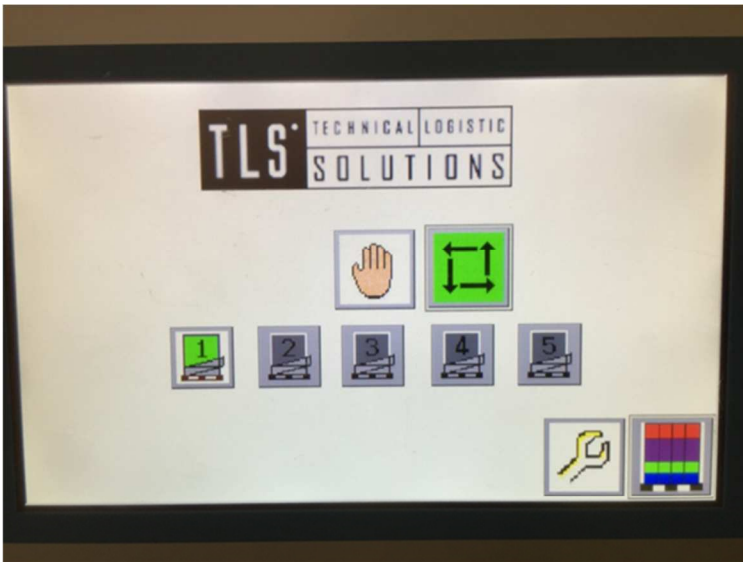

PACKSILVER 501 chemin de l'église 01600 Misérieux

 www.packsilver.fr

 **06 52 37 69 06**
04 27 11 75 47

 jdoizy@packsilver.fr

sas au capital de 40 000 € NAF 4669B 538 114 257 RCS Bourg en Bresse SIRET 538 114 257 00024 TVA FR10 538 114 257
IBAN FR64 3000 2010 5700 0009 9086 F58 BIC CRLYFRPP