



32MS

	P32X	32
Crimping range (mm) ¹⁾	10-87	10-87
Crimping range (inch) ¹⁾	0.39-3.42	0.39-3.42
Max. crimping force (kN)	2000	2000
Max. crimping force (tonnage)	200	200
Number of crimpings/hour ²⁾	134 / 411 ⁶⁾	200 / 850 ⁶⁾
Hose size ID (inch)	2	2
Die set ³⁾	P32	P32
Max. opening (mm) ⁴⁾	+33	+33
Master die D/L (mm)	99 / 80	99 / 80
Master die D/L (inch)	3.90 / 3.15	3.90 / 3.15
Control	MS	MS / UC
Motor (kW)	1.5 / 2.2 ⁵⁾	1.5 / 4 ⁵⁾
Motor (HP)	2.0 / 3.0 ⁵⁾	2.0 / 5.5 ⁵⁾
SIZE: length (mm)	632	800
width (mm)	521	630
height (mm)	567	637
SIZE: length (inch)	24.9	31.5
width (inch)	20.6	24.8
height (inch)	22.4	25.1
Weight (kg)	150	205
Weight (lbs)	331	550

Options:
QC-Tool
* Foot pedal
* Electric back stop device
Mechanical back stop device
** UC1, UC2

* not available in P32X-model
 ** not available in P32X and MS-models

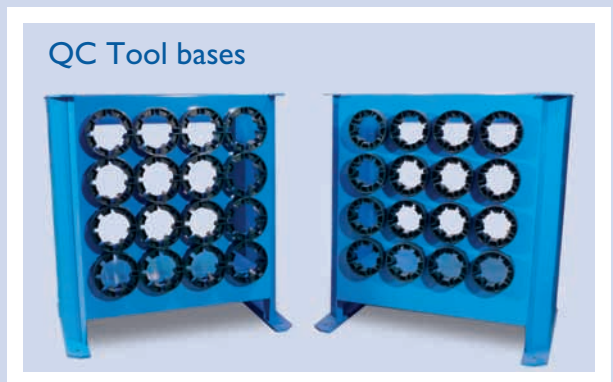

- 1) With standard dies. Crimping range can be increased with special dies.
- 2) Theoretical with 10 mm cycle
- 3) See table for die set data
- 4) Maximum opening is the total die travel. Add this value to the minimum crimping diameter of the die set used. The result is the maximum opening of the machine with die set in place.
- 5) 12V / 24V. Overload controlled.
- 6) 1-phase / 3-phase

Finn-Power 32MS and 32UC has the same fabulous crimping features as the 20 series of crimping machines. They are mid-range in terms of power, but compact from the point of view of space requirements.

32 machines provide 2000 kN crimping force in a highly compact, ergonomical design.

They are ideally suited for single-piece production in machine shops, repair workshops etc.

All table-top machines can be mounted on a QC Tool Base. Up to 16 die sets can be stored in a base for operator convenience.

32UC



P32CS



P32X

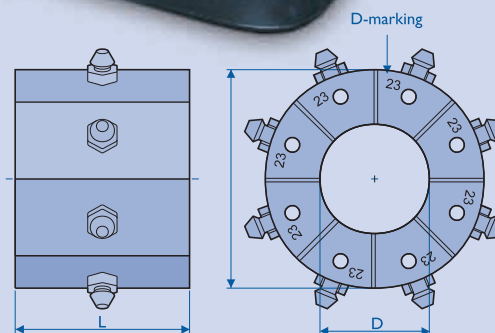

18506/xx
P32

Pno	Crimping range	D	L
18506/10	10.0 - 12.0	10	55
18506/12	12.0 - 14.0	12	55
18506/14	14.0 - 16.0	14	55
18506/16	16.0 - 19.0	16	55
18506/19	19.0 - 22.0	19	55
18506/22	22.0 - 26.0	22	70
18506/26	26.0 - 30.0	26	70
18506/30	30.0 - 34.0	30	70
18506/34	34.0 - 39.0	34	75
18506/39	39.0 - 45.0	39	75
18506/45	45.0 - 51.0	45	90
18506/51	51.0 - 57.0	51	90
18506/57	57.0 - 63.0	57	100
18506/63	63.0 - 69.0	63	110
18506/69	69.0 - 75.0	69	110
18506/74	74.0 - 80.0	74	110
18506/78	78.0 - 87.0	78	110