

TYPE 069



SPECIFICATIONS

VOLTAGE
12V

AH
68 AH

CCA (EN)
550 CCA(EN)

PALLET QUANTITY
48

LAYOUT
1

BASE HOLDOWN
B01

TERMINAL
1

EAN CODE
5060196060313

CASE TYPE
D26

TERMINAL

HOLDOWN

LAYOUT

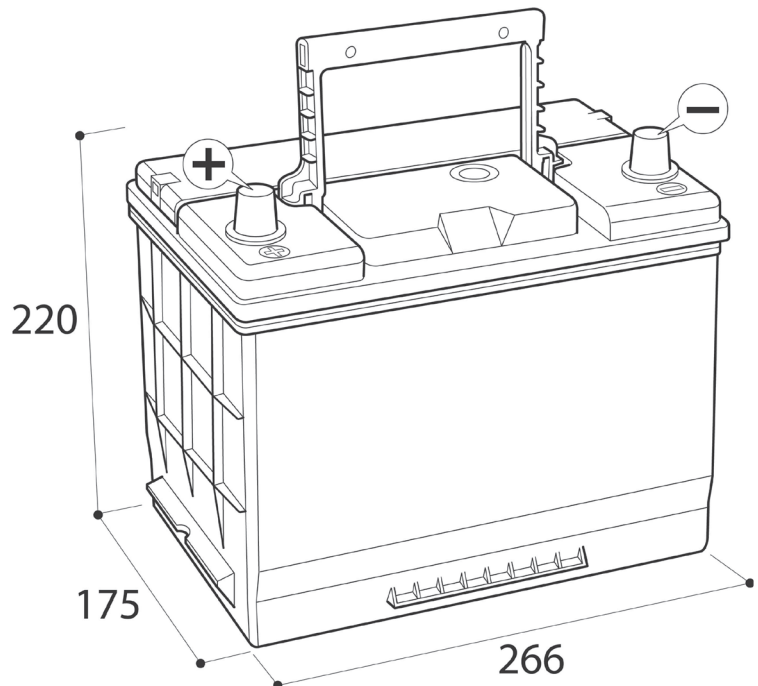

DIMENSIONS

LENGTH	266 mm
WIDTH	175 mm
HEIGHT	220 mm
WEIGHT	16.4 kgs

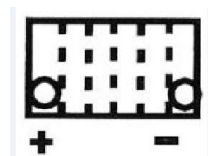
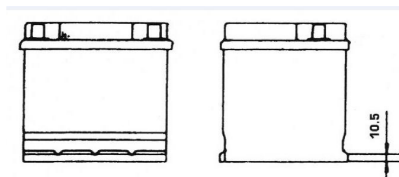
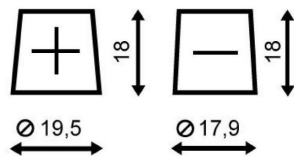

TRANSPORT INFORMATION

- Classified as "Batteries, Wet, Filled with Sulphuric Acid".
- UN2794
- Class 8
- Packing Group III

