

The Packo EHEDG and 3A certified process pumps of the FP2+ series are used in the most demanding hygienic applications in almost all industries such as dairies, breweries, beverage industry, distilleries, etc. These perfectly cleanable pumps have stainless steel 316L pump casings constructed in thick cold rolled plate, 100% non porous and extremely smooth. The pumps have open investment cast impellers, constructed in 316L or duplex materials. Thanks to its crevice-free design and electropolishing as a final surface treatment, the FP2+ pump series are perfectly cleanable, resulting in a reliable component into your production process.



### Application areas

These perfectly cleanable process pumps are the ideal solution for filtration applications, pasteurisation, evaporating systems, yeast propagation and for CIP cleaning systems as well. Typical applications include filtration of beer, wine and fruit juices as well as pumping yeast, whey and curd.

### Your benefits

- High pump efficiency resulting in lower energy consumption
- Low NPSH values: less risk on cavitation
- Electropolished: perfectly cleanable
- Easy construction and easy maintenance: Less downtime
- Easy to install
- Standard components
- 2 mechanical seal diameters for the entire range
- Robust construction

### Technical specifications

Max. flow rate	100 m <sup>3</sup> /h
Max. differential head	110 m
Max. liquid viscosity	500 cP
Max. temperature	140°C
Impeller type	Open
Max. free passage	22 mm
Max. motor power	45 kW
Max. speed	3000 / 3600 rpm
Available frequency	50 / 60 Hz
Connections	3A approved sanitary fittings only
Materials wetted parts	Stainless steel 316L or similar
Available materials o-ring	EPDM, FKM, FEP-FKM, FFKM, Silicone
Mechanical seal configuration	Single, quench, double
Surface finish	Food quality, internal welds hand polished + electropolished (wetted parts 0.8 µm)
Certificates & Legislation	EHEDG, 3A, 1935/2004 EC, FDA, USP, ATEX, EU N° 547/2012



### Performance curves at 2900 rpm

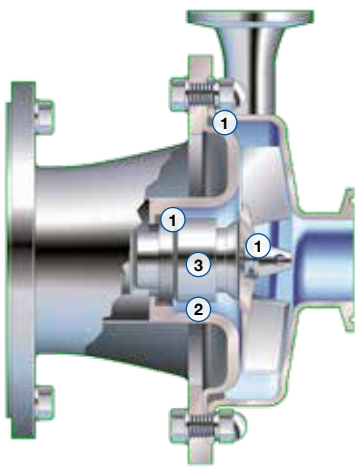
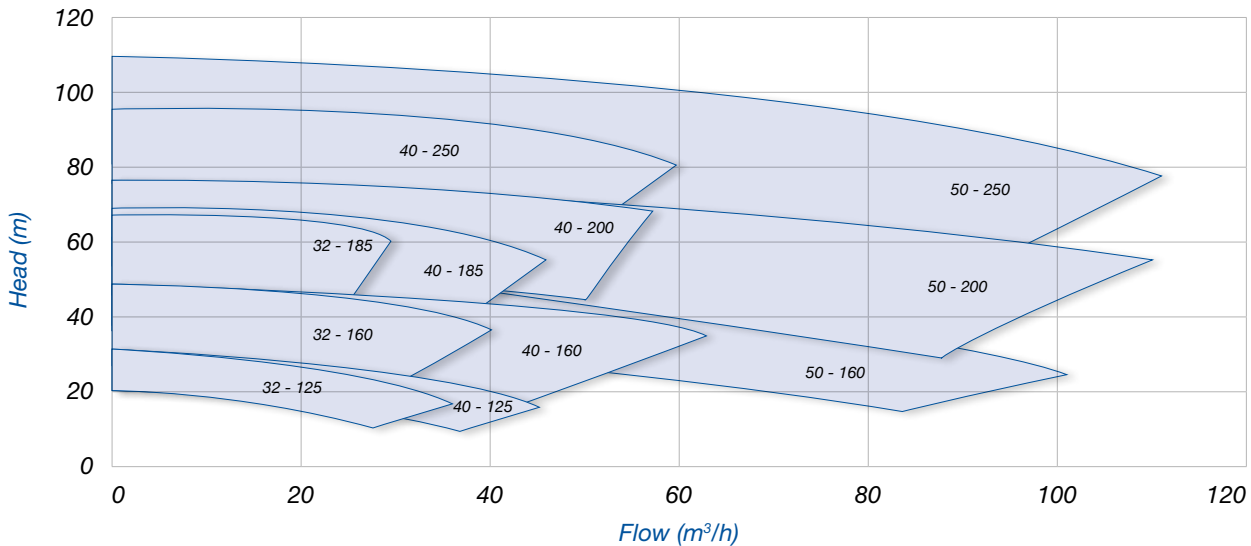

### Specifications

- Easy to clean construction and standardized components
- No bacteria traps and no small clearances in order to clean the area around the O-ring (1)
- Pressed stainless steel in 2B quality plate, extremely smooth
- Large seal cavity to clean mechanical seal properly (2)
- FDA approved sterile O-ring mechanical seals (spring not in contact with the liquid) (3)
- 1 mechanical seal diameter 33 mm up to 22 kW motor power (43 mm between 22 and 45 kW)
- Electropolished design (for wetted & non-wetted parts); easy to clean and increased corrosion resistance
- Roughness value <math>< 0.8 \mu\text{m}</math>



Electropolished

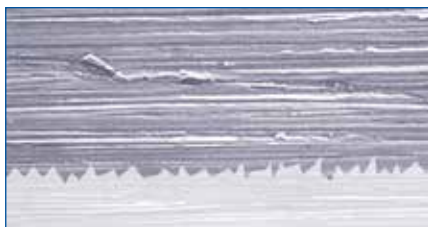

Mechanical polishing 240 grit

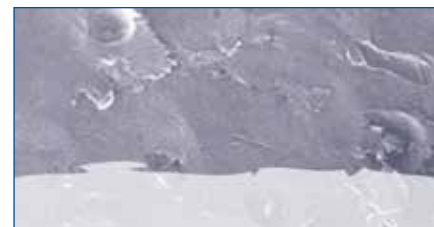

Glass bead blasted

FP2+\_Sanitary\_pump\_series\_Technosheet\_rev01\_2016\_(eu)



Find your local supplier at [www.verder-liquids.com](http://www.verder-liquids.com)

For construction, installation and floor mounting drawings please contact your local authorised Verder® distributor.