

900

VANNE PAPILLON TYPE "WAFER" WAFER BUTTERFLY VALVES

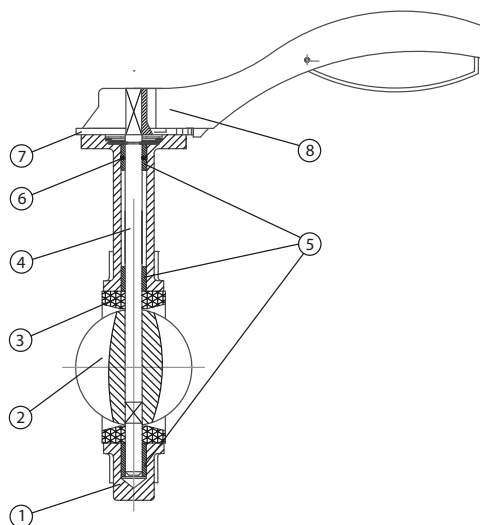

CE



DESCRIPTION DES COMPOSANTS - COMPONENTS DESCRIPTION

Index - Ítem	Description - Descripción	Matière - Material
1	Corps - Body	Fonte Grise - Grey Cast Iron GG 25 (EN-GJL-250)
2	Disque - Disc	Acier Inoxydable - Stainless Steel AISI 316 (CF8M)
3	Siège - Seat	EPDM
4	Axe - Stem	Acier Inoxydable - Stainless Steel AISI 416
5	Paliers - Bushing	PTFE
6	Joints Toriques - O-Ring	EPDM
7	Secteur cranté - Indicator Plate	Acier - Carbon Steel
8	Poignée - Hand Lever	Aluminium - Aluminium

CARACTERISTIQUES

- Pression de travail PN 16.
- Température de service: de -10 °C à +120 °C.
- Montage avec Brides PN 10/16.
- Revêtement extérieur "EPOXY", 250 µm.
- Embase ISO 5211 pour le montage d'actionneur.
- Vanne de régulation.
- Axe en une seule pièce.
- Pas de crochet pour raccorder le disque et l'axe.
- Ne nécessite pas de joint pour un montage entre Brides.
- Col allongé pour une meilleure isolation thermique.
- Design bidirectionnel.

DOMAINES D'APPLICATION

- Systèmes hydrauliques.
- Adduction d'eau et pompage.
- Applications industrielles basse pression et basse température.
- Installations d'irrigation.
- Ouvrages hydrauliques civiles.
- Climatisation.

BASIC FEATURES

- Working pressure PN 16.
- Working temperature: -10 °C to 120 °C.
- Suitable for flanges PN 10 / PN 16.
- Outside "EPOXY" powder coating, 250 µm.
- Top flange ISO 5211 for actuator.
- Control valve.
- One piece stem.
- Not pins to joint disc and stem.
- No need gaskets between valve and counter flanges.
- Long neck to facilitate thermal isolation.
- Bidirectional design.

GENERAL APPLICATIONS

- Water systems.
- Water supply, pumping and connection plants.
- Low pressure and low temperature industrial applications.
- Irrigation systems.
- Hydraulic and civil works.
- HVAC systems.

Rev.0-03.19
1/2



Polígono Industrial ATUSA - Agurain S/N - 01200 Salvatierra (Alava) España
Tel.: (+34) 945 18 00 00 Fax : (+34) 945 30 01 53 e-mail: ventas@atusa.es
www.atusa.es



900

VANNE PAPILLON TYPE "WAFER" WAFER BUTTERFLY VALVES

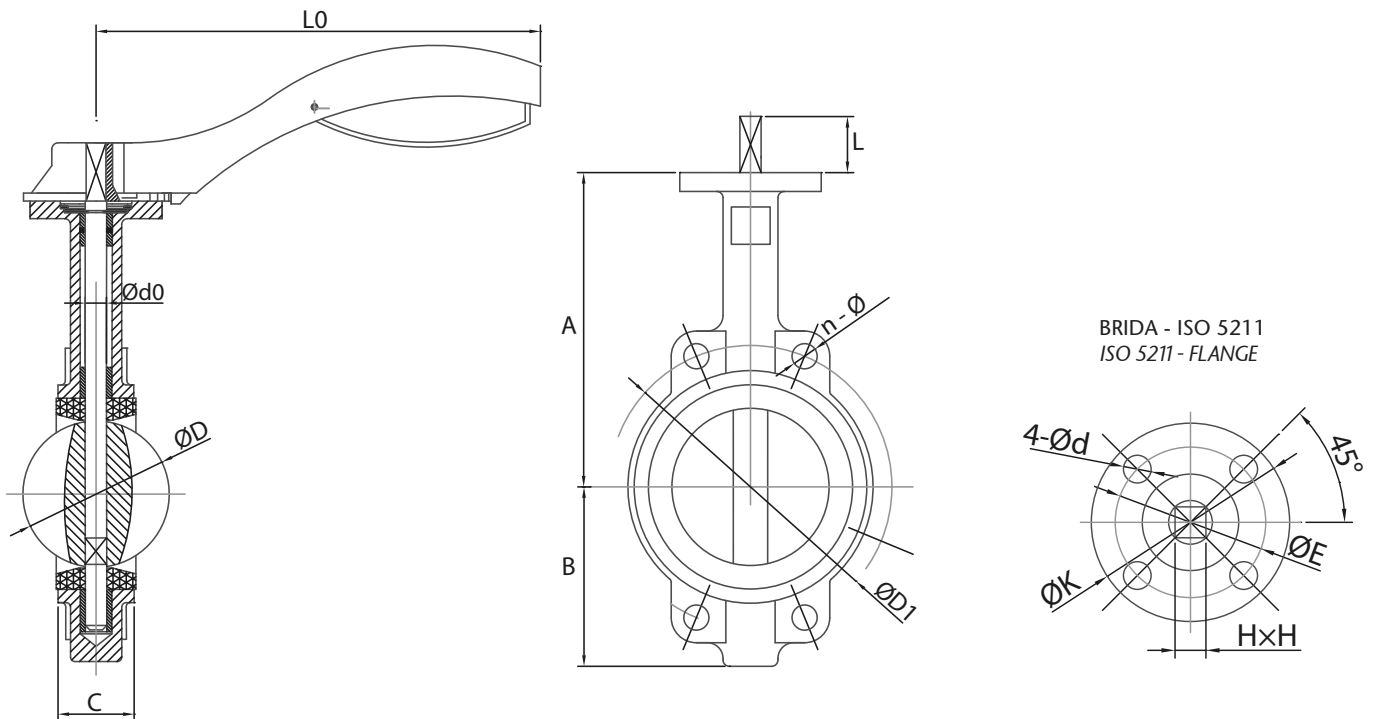

INFORMATION TECHNIQUE - TECHNICAL INFORMATION

DN	CODE	DIMENSIONS - DIMENSIONS (mm)										BRIDE/FLANGE - ISO 5211			Poids approx. Weight approx. (kg)	
		A	B	C	Ød0	ØD	ØD1	n - Ø	L	L0	H x H	4 - Ød	K	E		
40	VF900040	150	65	33	12,6	42,8	110	4 - 19	24	170	9 x 9	F05	4 - 7	70	50	2,6
50	VF900050	161	75	42	12,6	52,9	125	4 - 19	29	170	9 x 9	F05	4 - 7	70	50	2,8
65	VF900065	175	89	45	12,6	64,5	145	4 - 19	29	170	9 x 9	F05	4 - 7	70	50	3,1
80	VF900080	181	95	46	12,6	78,8	160	8 - 19	26	170	11 x 11	F05	4 - 7	70	50	3,5
100	VF900100	200	114	52	15,8	104,0	180	4 - 19	26	170	11 x 11	F05	4 - 7	70	50	4,6
125	VF900125	213	127	55	18,9	123,3	210	4 - 19	28	220	14 x 14	F07	4 - 9	90	70	6,6
150	VF900150	226	139	56	18,9	155,1	240	4 - 23	32	220	14 x 14	F07	4 - 9	90	70	8,2
200	VF900200	260	175	61	22,1	202,5	295	4 - 23	29	260	17 x 17	F07	4 - 9	90	70	12,5
250	VF900250	292	203	66	28,5	250,5	355	4 - 28	38	350	22 x 22	F10	4 - 12	125	102	19,5
300	VF900300	337	242	77	31,6	301,6	410	4 - 28	34	350	22 x 22	F10	4 - 12	125	102	30,1

Note : En raison de l'évolution constante de nos produits, ces spécifications peuvent être modifiées sans préavis.

Note : Due to the continuous development of our products, specifications may be changed without notification at any time.

Rev.0-03.19
2/2



Polígono Industrial ATUSA - Agurain S/N - 01200 Salvatierra (Alava) España
Tel.: (+34) 945 18 00 00 Fax : (+34) 945 30 01 53 e-mail: ventas@atusa.es
www.atusa.es

