



PE160FE-BASCUL

Ensemble composé du pétrin modèle PE160FE et d'un levier hydraulique basculant

Châssis en acier et carbone
 Garde corps de protection

2 hauteurs d'élévation, 140 cm ou 180 cm
 Montée et descente par vérin hydraulique
 Valve de sécurité pour la descente en cas de chute de pression

PE160FE-BASCUL

Set including PE160FE kneader and a hydraulic lifter

Structure in carbon steel
 Safety bar against accidents

2 heights of rise 140 cm or 180 cm
 Hydraulic cylinder for lifting and lowering
 Safety valve for lowering in case of pressure failure

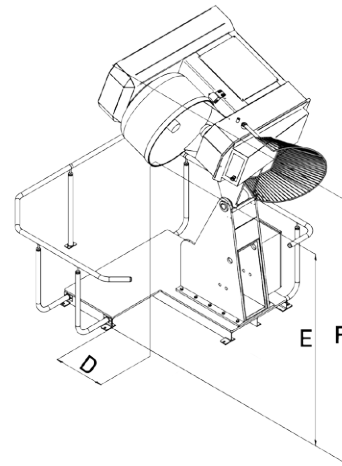
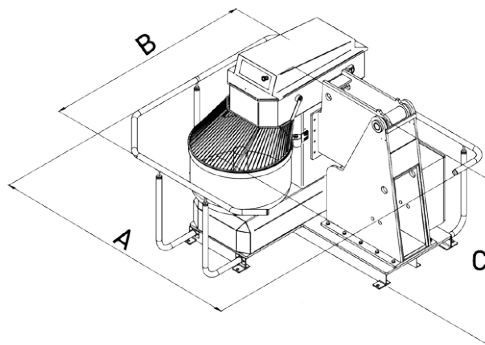

PE160FE-BASCUL234

PE160FE-BASCUL274

Dimensions / Dimensions

A mm	2195	2195
B mm	1895	1895
C mm	1540	1565
D mm	185	230
E mm	1450	1885
F mm	2480	2855
Poids / Weight		
Kg	1350	1493
Puissance du système hydraulique / Hydraulic system power		
kW	1.5	1.5
Voltage / Voltage		
	TRI – 400V – 50/60Hz	