



b.o.b. Sistemi Idraulici S.p.A.

ampliner[®]

COMPANY WITH QUALITY MANAGEMENT
SYSTEM CERTIFIED BY DNV
= ISO 9001:2008 =

BRAS DE LEVAGE « TAL 26 »

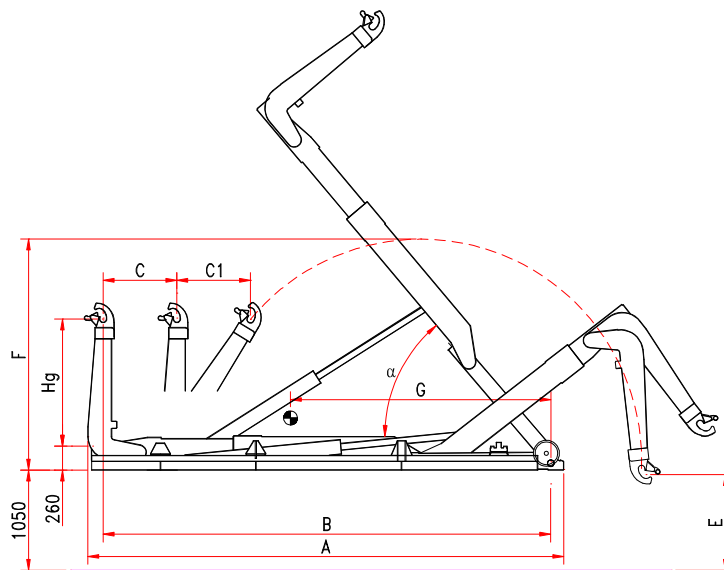

Modèle	Hg	A	B	C-C1	E	F	G	Poids kit	α	Conteneur	min – max
TAL 26 C	1.425/1.570	6.150	5.750	850/1.150	920/800	2.890	3.400	3.010 kg	57°		4.400 6.900
TAL 26 NC	1.425/1.570	6.350	5.950	850/1.150	920/800	2.890	3.500	3.040 kg	53°		4.600 7.100
TAL 26 N	1.425/1.570	6.550	6.150	850/1.150	920/800	2.890	3.600	3.070 kg	51°		4.800 7.300
TAL 26 NL	1.425/1.570	6.750	6.350	850/1.150	920/800	2.890	3.700	3.100 kg	48°		5.000 7.500
TAL 26 L	1.425/1.570	6.950	6.550	850/1.150	920/800	2.890	3.800	3.130 kg	45°		4.400 6.900

Les données de la présente fiche technique sont indicatives et peuvent être changées par le constructeur sans préavis.

B.O.B. Sistemi Idraulici S.p.A. – Regione Oltre Rea, 61 – 12060 Monchiero (CN) - Italia

P. I.V.A. 00496180043 - Tel.: +39 (0173) 780002/3 – Fax: +39 (0173) 780004

Internet: www.bobspa.com - E-mail: info@bobitalev.com