

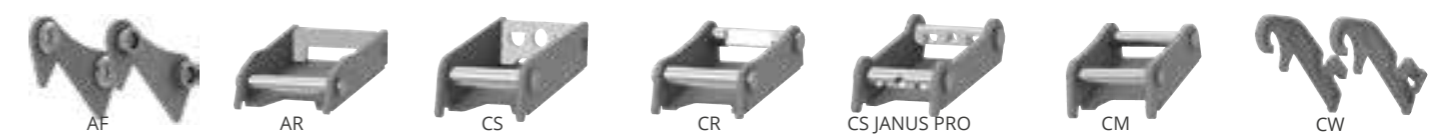

SA FORME EST CONÇUE POUR FAVORISER LA CAPACITÉ DE PÉNÉTRATION DES TERRAINS DURS OU ROCHEUX. EQUIPÉ DE BANDES DE RENFORCEMENT, TRANCHANTS, PROTÈGE-LAME EN HB400, POUR UNE HAUTE RÉSISTANCE À L'USURE.

MOD.	MIDI								EXCAVATOR			
	SCR36	SCR38	SCR45	SCR53	SCR62	SCR67	SCR73	SCR80	SCR85	SCR92 HD	SCR100 HD	SCR110 HD
TONS	1,2 - 1,8	1,2 - 1,8	1,8 - 2,5	2,5 - 4,0	4,0 - 5,0	5,0 - 7,5	7,5 - 10,0	10,0 - 12,0	12,0 - 14,0	12,0 - 14,0	14,0 - 18,0	18,0 - 22,0



ADAPTERS

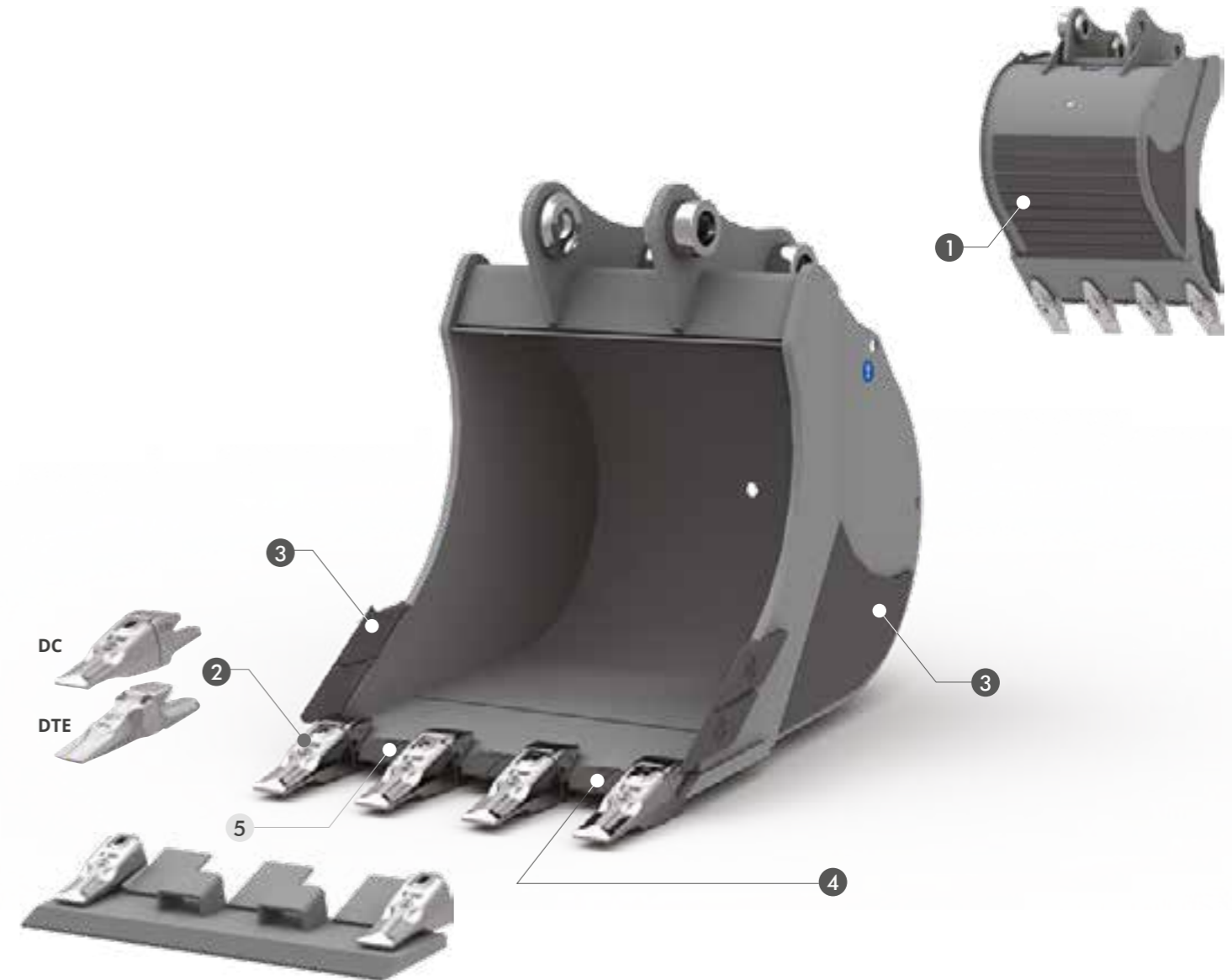

CARACTERISTIQUES TECHNIQUES STANDARD

- 1 BANDES DE RENFORCEMENT HB 400**
LES BANDES DE RENFORCEMENT HORIZONTALES PROTÈGENT LE FOND EN AUGMENTANT SA RÉSISTANCE À L'USURE.
- 2 DENTS DC DENTS DTE**
- 3 TRANCHANTS ET BANDES LATÉRALES DE RENFORCEMENT EN FUSION HB400**
RÉALISÉS EN FUSION HB400 ET PLACÉS SUR LES SURFACES LES PLUS EXPOSÉES DONNENT PLUS DE RÉSISTANCE À L'USURE.
- 4 LAME RENFORCEE**
BOULIERS HB400 EN FUSION PLACÉS SUR LES PARTIES LES PLUS EXPOSÉES, JUSQU'À 10 TONNES.
LAME EN HB400 POUR GODETS EXCÉDANT 10 TONNES.

EN OPTION

- 5 LAME SUPPLÉMENTAIRE**
INSTALLÉE SUR LE PORTE-DENTS. CETTE CONFIGURATION PERMET DES OPERATIONS D'INSTALLATION/DÉSINSTALLATION PLUS AISÉES EN ASSURANT UNE RÉSISTANCE ACCRUE AU SYSTÈME.

SCR36 POIDS MACHINE 1,2 - 1,8

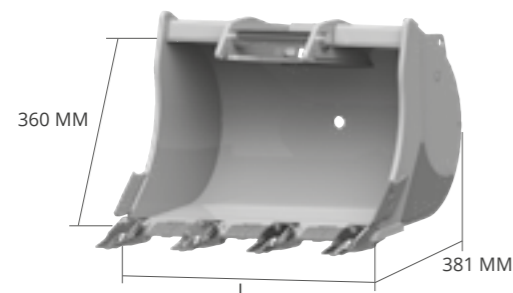
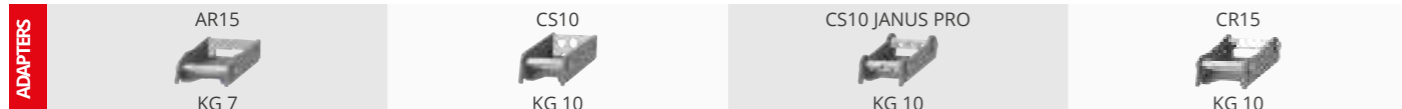

L MM	POIDS KG*	CAP. SAE L	DENTS N°	ADAPTERS
200	17	15	2	AR - CS
				CR
				CS JANUS PRO
250	19	20	DF2 DC3 DE3	AR - CS
				CR
				CS JANUS PRO
300	22	25	3	AR - CS
				CR
				CS JANUS PRO
350	24	31	3	AR - CS
				CR
				CS JANUS PRO
400	28	37	3	AR - CS
				CR
				CS JANUS PRO
450	31	43	3	AR - CS
				CR
				CS JANUS PRO
500	35	49	4	AR - CS
				CR
				CS JANUS PRO
600	39	61	4	AR - CS
				CR
				CS JANUS PRO
700	44	74	5	AR - CS
				CR
				CS JANUS PRO

* poids cuve sans attache

SCR38 POIDS MACHINE 1,2 - 1,8

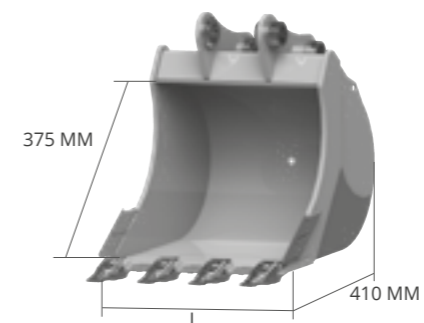
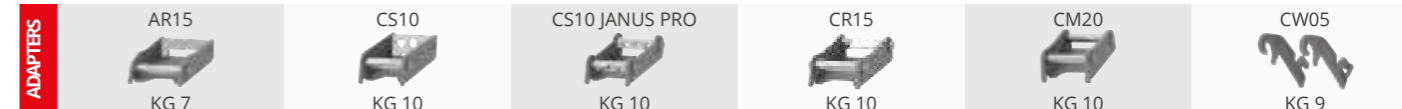

L MM	POIDS KG*	CAP. SAE L	DENTS N°	ADAPTERS
200	17	15	2	AF - AR - CS
				CR - CM
				CW - CS JANUS PRO
250	19	20	DF2 DC3 DE3	AF - AR - CS
				CR - CM
				CW - CS JANUS PRO
300	22	25	3	AF - AR - CS
				CR - CM
				CW - CS JANUS PRO
350	24	31	3	AF - AR - CS
				CR - CM
				CW - CS JANUS PRO
400	28	37	3	AF - AR - CS
				CR - CM
				CW - CS JANUS PRO
450	31	43	3	AF - AR - CS
				CR - CM
				CW - CS JANUS PRO
500	35	49	4	AF - AR - CS
				CR - CM
				CW - CS JANUS PRO
600	39	61	4	AF - AR - CS
				CR - CM
				CW - CS JANUS PRO
700	44	74	5	AF - AR - CS
				CR - CM
				CW - CS JANUS PRO

* poids cuve sans attache

EN OPTION

5
LAME SUPPLÉMENTAIRE

EN OPTION

5
LAME SUPPLÉMENTAIRE

SCR45 POIDS MACHINE 1,8 - 2,5

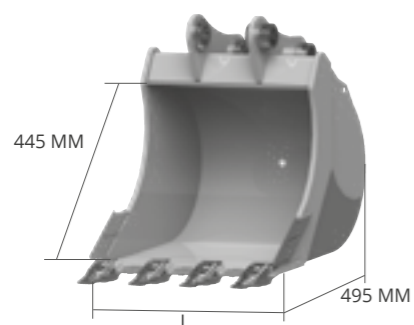

L MM	POIDS KG*	CAP. SAE L	DENTS N°	ADAPTERS
250	26	25	DF2 DC3 DE3	AF - AR - CS
				CR - CM
				CW - CS JANUS PRO
300	29	33	3	AF - AR - CS
				CR - CM
				CW - CS JANUS PRO
350	32	40	3	AF - AR - CS
				CR - CM
				CW - CS JANUS PRO
400	36	48	3	AF - AR - CS
				CR - CM
				CW - CS JANUS PRO
450	39	56	3	AF - AR - CS
				CR - CM
				CW - CS JANUS PRO
500	43	65	4	AF - AR - CS
				CR - CM
				CW - CS JANUS PRO
600	50	82	4	AF - AR - CS
				CR - CM
				CW - CS JANUS PRO
700	56	100	5	AF - AR - CS
				CR - CM
				CW - CS JANUS PRO
800	65	117	5	AF - AR - CS
				CR - CM
				CW - CS JANUS PRO

* poids cuve sans attache

SCR53 POIDS MACHINE 2,5 - 4,0

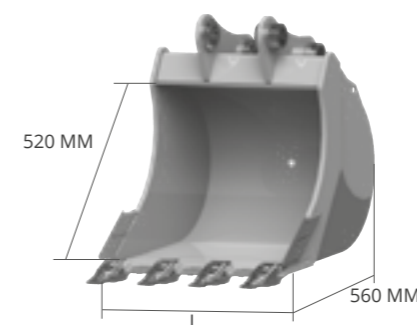
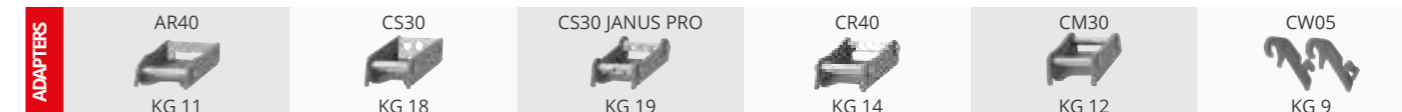

L MM	POIDS KG*	CAP. SAE L	DENTS N°	ADAPTERS
250	37	32	2	AF - AR - CS
				CR - CM
				CW - CS JANUS PRO
300	40	41	3	AF - AR - CS
				CR - CM
				CW - CS JANUS PRO
350	46	51	3	AF - AR - CS
				CR - CM
				CW - CS JANUS PRO
400	51	61	3	AF - AR - CS
				CR - CM
				CW - CS JANUS PRO
450	55	72	3	AF - AR - CS
				CR - CM
				CW - CS JANUS PRO
500	59	82	4	AF - AR - CS
				CR - CM
				CW - CS JANUS PRO
600	67	105	4	AF - AR - CS
				CR - CM
				CW - CS JANUS PRO
700	76	127	5	AF - AR - CS
				CR - CM
				CW - CS JANUS PRO
800	85	152	5	AF - AR - CS
				CR - CM
				CW - CS JANUS PRO
900	93	175	5	AF - AR - CS
				CR - CM
				CW - CS JANUS PRO

* poids cuve sans attache

EN OPTION

5
LAME SUPPLÉMENTAIRE

EN OPTION

5
LAME SUPPLÉMENTAIRE

SCR62 POIDS MACHINE 4,0 - 5,0

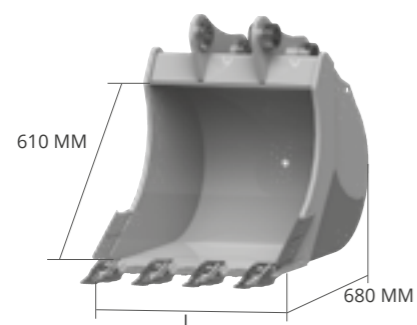
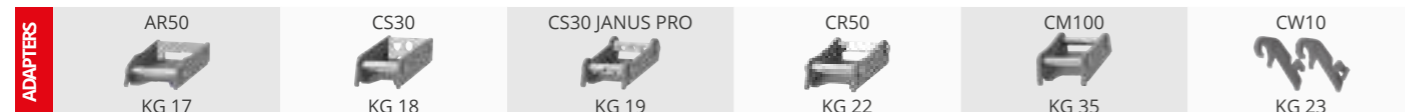

L MM	POIDS KG*	CAP. SAE L	DENTS N°	ADAPTERS
250	57	45	2	AF - AR - CS
				CR - CM
				CW - CS JANUS PRO
300	63	58	3	AF - AR - CS
				CR - CM
				CW - CS JANUS PRO
350	68	71	3	AF - AR - CS
				CR - CM
				CW - CS JANUS PRO
400	74	85	3	AF - AR - CS
				CR - CM
				CW - CS JANUS PRO
450	79	100	3	AF - AR - CS
				CR - CM
				CW - CS JANUS PRO
500	86	115	4	AF - AR - CS
				CR - CM
				CW - CS JANUS PRO
600	97	147	4	AF - AR - CS
				CR - CM
				CW - CS JANUS PRO
700	109	180	5	AF - AR - CS
				CR - CM
				CW - CS JANUS PRO
800	121	213	5	AF - AR - CS
				CR - CM
				CW - CS JANUS PRO
900	133	248	6	AF - AR - CS
				CR - CM
				CW - CS JANUS PRO
1000	145	282	6	AF - AR - CS
				CR - CM
				CW - CS JANUS PRO

* poids cuve sans attache

SCR67 POIDS MACHINE 5,0 - 7,5

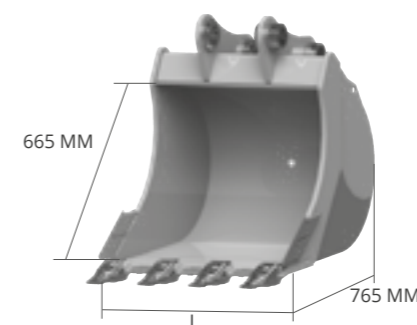
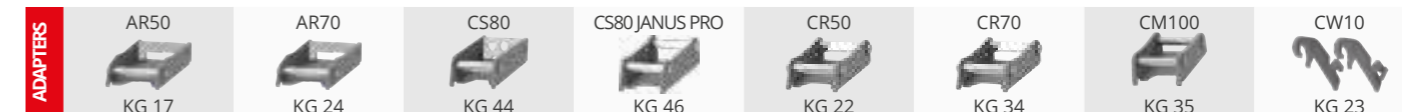

L MM	POIDS KG*	CAP. SAE L	DENTS N°	ADAPTERS
300	83	68	3	AF - AR - CS
				CR - CM
				CW - CS JANUS PRO
350	92	84	3	AF - AR - CS
				CR - CM
				CW - CS JANUS PRO
400	101	101	3	AF - AR - CS
				CR - CM
				CW - CS JANUS PRO
450	109	118	3	AF - AR - CS
				CR - CM
				CW - CS JANUS PRO
500	117	137	4	AF - AR - CS
				CR - CM
				CW - CS JANUS PRO
600	134	174	4	AF - AR - CS
				CR - CM
				CW - CS JANUS PRO
700	150	214	5	AF - AR - CS
				CR - CM
				CW - CS JANUS PRO
800	167	254	5	AF - AR - CS
				CR - CM
				CW - CS JANUS PRO
900	183	295	6	AF - AR - CS
				CR - CM
				CW - CS JANUS PRO
1000	199	338	6	AF - AR - CS
				CR - CM
				CW - CS JANUS PRO

* poids cuve sans attache

EN OPTION

5
LAME SUPPLÉMENTAIRE

EN OPTION

5
LAME SUPPLÉMENTAIRE

SCR73 POIDS MACHINE 7,5 - 10,0

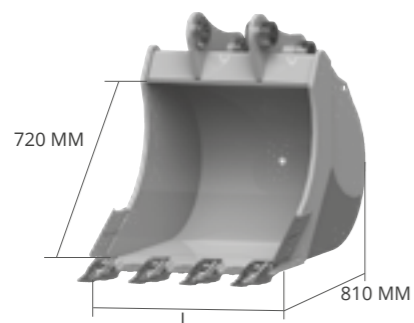

EN OPTION

5
LAME SUPPLÉMENTAIRE

L MM	POIDS KG*	CAP. SAE L	DENTS N°	ADAPTERS
300	95	76	2	AF - CS
				CR - CM
				CW - CS JANUS PRO
350	103	94	3	AF - CS
				CR - CM
				CW - CS JANUS PRO
400	110	113	3	AF - CS
				CR - CM
				CW - CS JANUS PRO
450	120	133	3	AF - CS
				CR - CM
				CW - CS JANUS PRO
500	130	153	3	AF - CS
				CR - CM
				CW - CS JANUS PRO
600	148	196	4	AF - CS
				CR - CM
				CW - CS JANUS PRO
700	166	240	4	AF - CS
				CR - CM
				CW - CS JANUS PRO
800	184	286	5	AF - CS
				CR - CM
				CW - CS JANUS PRO
900	202	333	5	AF - CS
				CR - CM
				CW - CS JANUS PRO
1000	220	379	5	AF - CS
				CR - CM
				CW - CS JANUS PRO
1100	238	430	5	AF - CS
				CR - CM
				CW - CS JANUS PRO

* poids cuve sans attache

SCR80 POIDS MACHINE 10,0 - 12,0

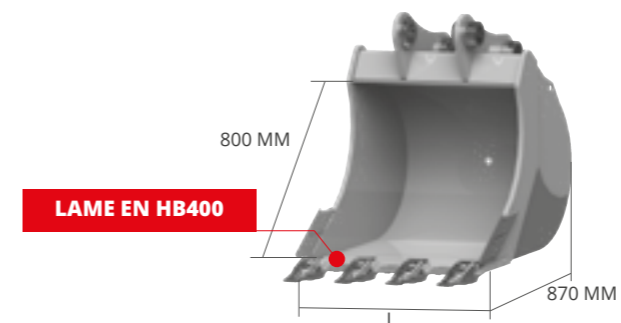

EN OPTION

5
LAME SUPPLÉMENTAIRE

L MM	POIDS KG*	CAP. SAE L	DENTS N°	ADAPTERS
300	119	86	2	AF - CS
				CR - CM - CS JANUS PRO
				CW
350	128	107	3	AF - CS
				CR - CM - CS JANUS PRO
				CW
400	141	129	3	AF - CS
				CR - CM - CS JANUS PRO
				CW
450	151	151	3	AF - CS
				CR - CM - CS JANUS PRO
				CW
500	162	174	3	AF - CS
				CR - CM - CS JANUS PRO
				CW
600	182	222	4	AF - CS
				CR - CM - CS JANUS PRO
				CW
700	203	273	4	AF - CS
				CR - CM - CS JANUS PRO
				CW
800	222	325	5	AF - CS
				CR - CM - CS JANUS PRO
				CW
900	242	379	5	AF - CS
				CR - CM - CS JANUS PRO
				CW
1000	261	433	5	AF - CS
				CR - CM - CS JANUS PRO
				CW
1100	282	486	5	AF - CS
				CR - CM - CS JANUS PRO
				CW
1200	303	546	6	AF - CS
				CR - CM - CS JANUS PRO
				CW
1300	323	602	6	AF - CS
				CR - CM - CS JANUS PRO
				CW

* poids cuve sans attache

SCR85 MIDI POIDS MACHINE 12,0 - 14,0

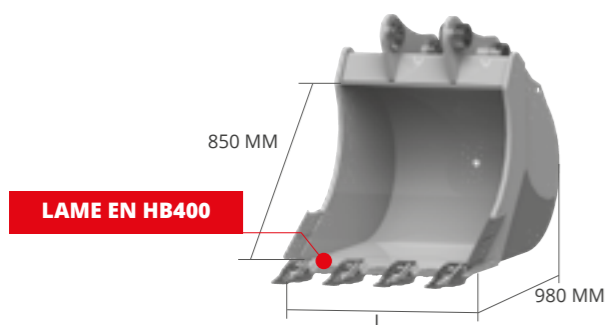
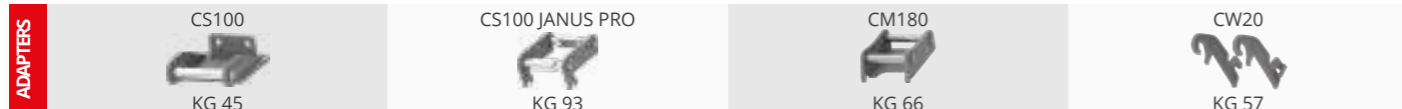

L MM	POIDS KG*	CAP. SAE L	DENTS N°	ADAPTERS
400	197	171	3	AF - CM
				CS - CW
				CS JANUS PRO
500	220	235	3	AF - CM
				CS - CW
				CS JANUS PRO
600	243	300	4	AF - CM
				CS - CW
				CS JANUS PRO
700	266	368	4	AF - CM
				CS - CW
				CS JANUS PRO
800	289	438	5	AF - CM
				CS - CW
				CS JANUS PRO
900	312	510	5	AF - CM
				CS - CW
				CS JANUS PRO
1000	336	584	5	AF - CM
				CS - CW
				CS JANUS PRO
1100	360	657	5	AF - CM
				CS - CW
				CS JANUS PRO
1200	384	730	6	AF - CM
				CS - CW
				CS JANUS PRO
1300	408	810	6	AF - CM
				CS - CW
				CS JANUS PRO

* poids cuve sans attache

SCR92 HD EXCAVATOR POIDS MACHINE 12,0 - 14,0

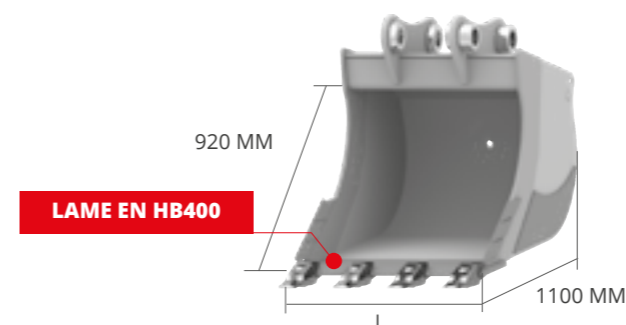
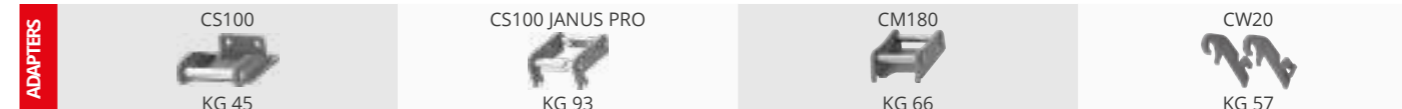

L MM	POIDS KG*	CAP. SAE L	DENTS N°	ADAPTERS
600	261	380	4	AF - CM
				CS - CW
				CS JANUS PRO
700	287	450	4	AF - CM
				CS - CW
				CS JANUS PRO
800	320	560	5	AF - CM
				CS - CW
				CS JANUS PRO
900	352	620	5	AF - CM
				CS - CW
				CS JANUS PRO
1000	395	700	5	AF - CM
				CS - CW
				CS JANUS PRO
1200	454	900	6	AF - CM
				CS - CW
				CS JANUS PRO

* poids cuve sans attache

EN OPTION

5
LAME SUPPLÉMENTAIRE

EN OPTION

5
LAME SUPPLÉMENTAIRE

SCR100 HD POIDS MACHINE 14,0 - 18,0

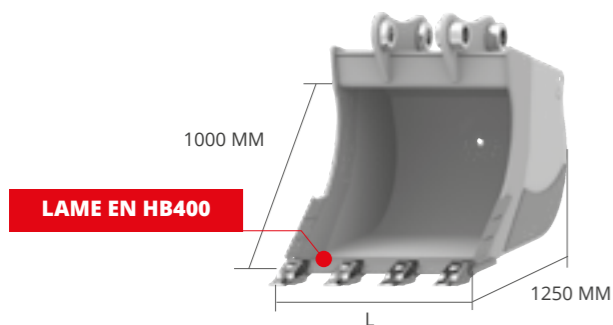
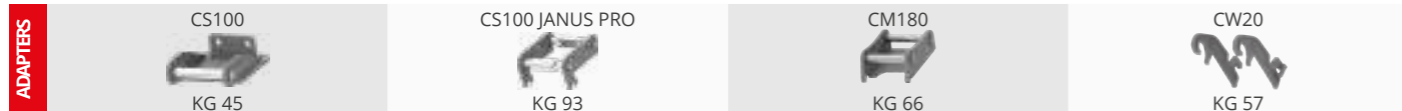

L MM	POIDS KG*	CAP. SAE L	DENTS N°	ADAPTERS
600	353	450	3	AF - CM
				CS - CW
				CS JANUS PRO
700	397	535	4	AF - CM
				CS - CW
				CS JANUS PRO
800	441	620	4	AF - CM
				CS - CW
				CS JANUS PRO
900	485	710	4	AF - CM
				CS - CW
				CS JANUS PRO
1000	529	800	5	AF - CM
				CS - CW
				CS JANUS PRO
1200	617	980	5	AF - CM
				CS - CW
				CS JANUS PRO

* poids cuve sans attache

SCR110 HD POIDS MACHINE 18,0 - 22,0

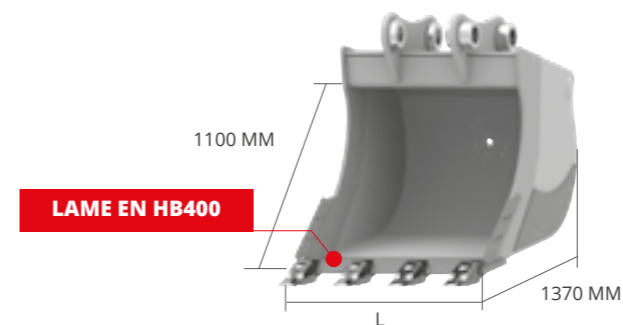
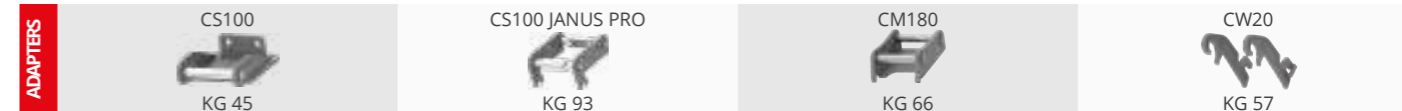

L MM	POIDS KG*	CAP. SAE L	DENTS N°	ADAPTERS
600	457	480	3	AF - CM
				CS - CW
				CS JANUS PRO
800	559	690	4	AF - CM
				CS - CW
				CS JANUS PRO
1000	671	900	5	AF - CM
				CS - CW
				CS JANUS PRO
1200	773	1110	5	AF - CM
				CS - CW
				CS JANUS PRO
1300	824	1220	6	AF - CM
				CS - CW
				CS JANUS PRO
1400	875	1330	6	AF - CM
				CS - CW
				CS JANUS PRO

* poids cuve sans attache

EN OPTION

5
LAME SUPPLÉMENTAIRE

EN OPTION

5
LAME SUPPLÉMENTAIRE

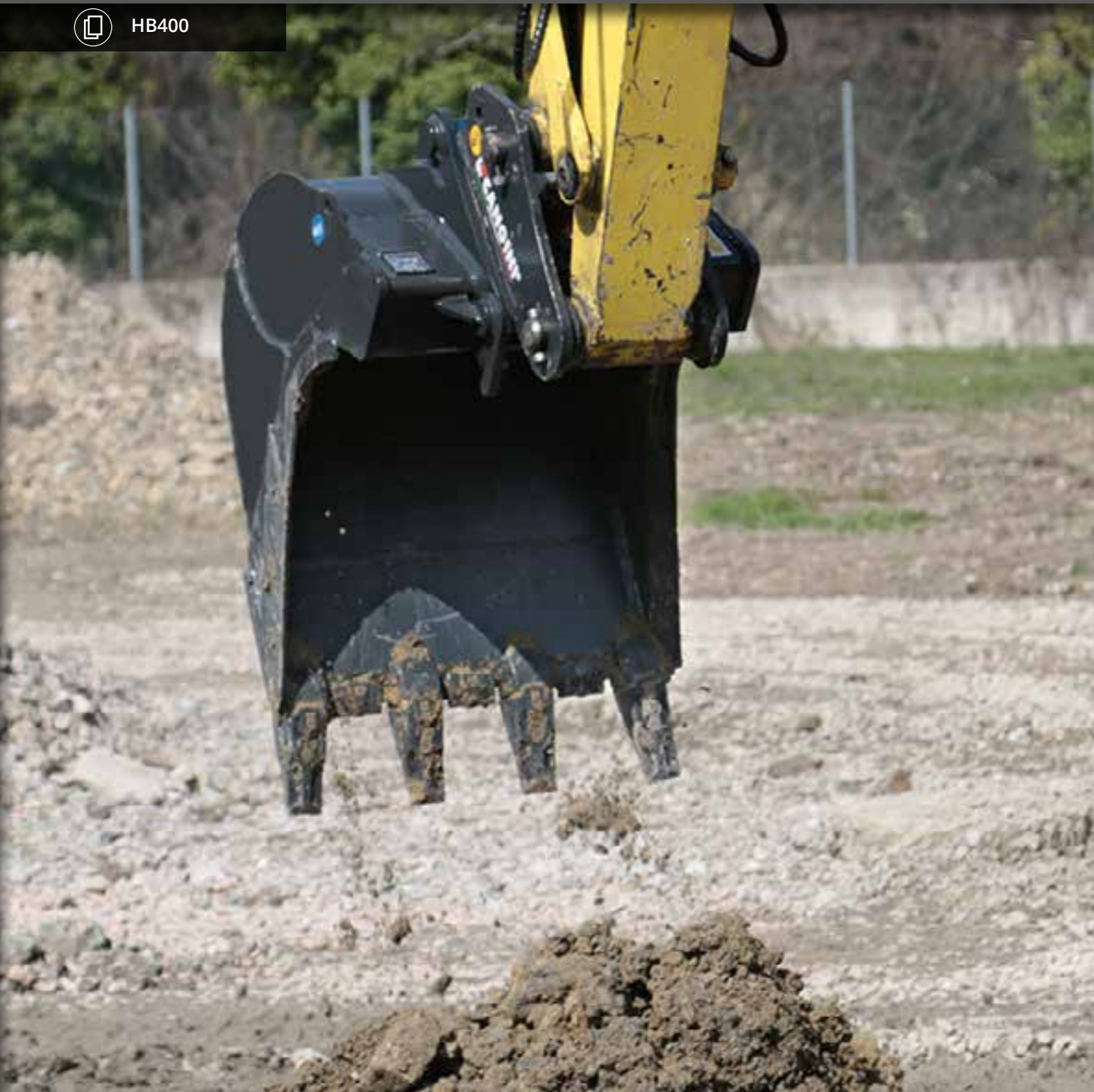

SA STRUCTURE PARTICULIÈRE LE DESTINE À LA MANUTENTION AISÉE ET STABLE DE BLOCS ROCHEUX. L'EMPLOI DE MATÉRIAUX EN HB400 GARANTIT L'HAUTE RÉSISTANCE DES PARTIES EXPOSÉES À L'USURE.

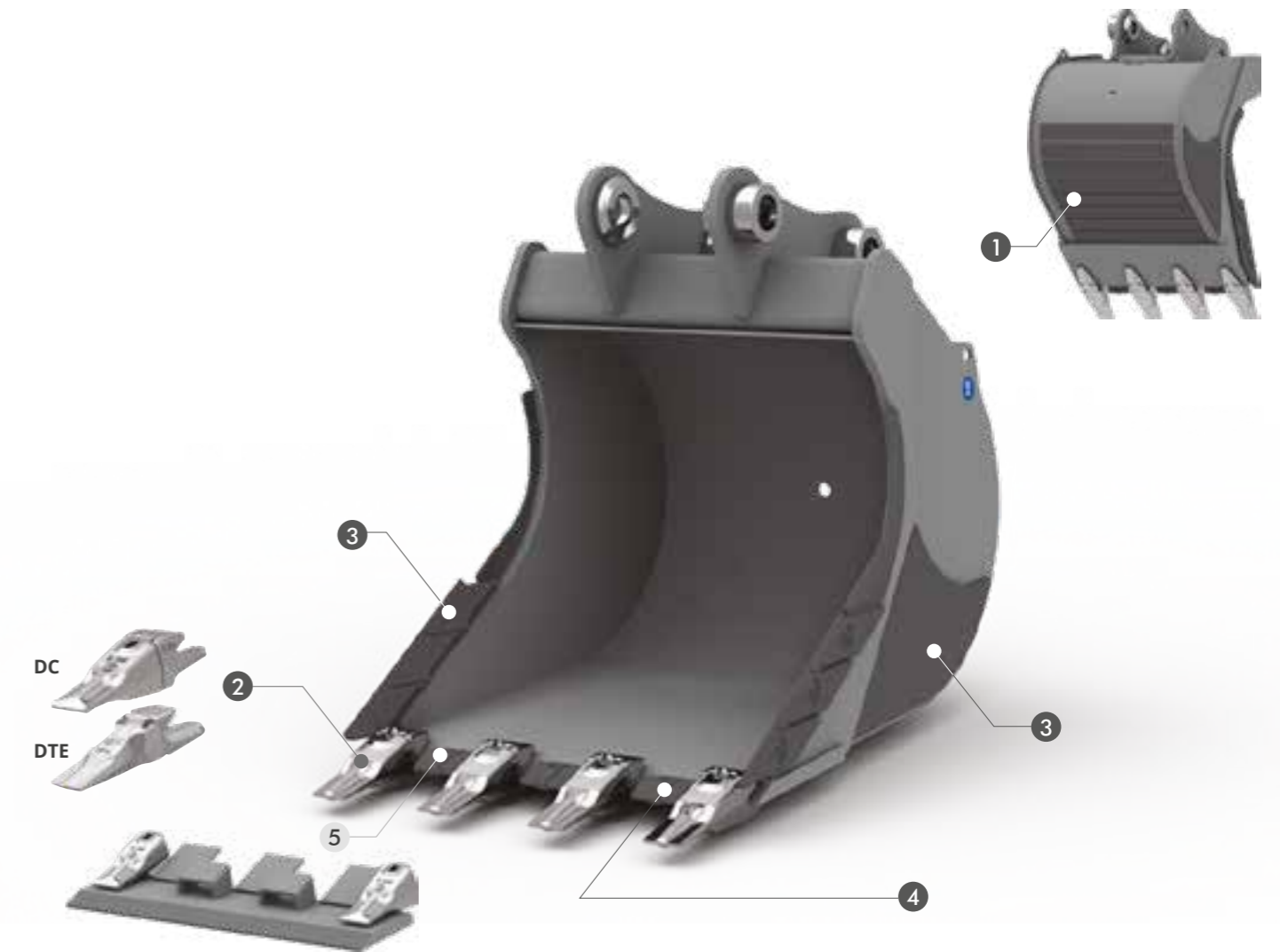

CARACTERISTIQUES TECHNIQUES STANDARD

- 1 BANDES DE RENFORCEMENT HB 400**
LES BANDES DE RENFORCEMENT HORIZONTALES PROTÈGENT LE FOND EN AUGMENTANT SA RÉSISTANCE À L'USURE.
- 2 DENTS DC DENTS DTE**
- 3 TRANCHANTS ET BANDES LATÉRALES DE RENFORCEMENT EN FUSION HB400**
RÉALISÉS EN FUSION HB400 ET PLACÉS SUR LES SURFACES LES PLUS EXPOSÉES DONNENT PLUS DE RÉSISTANCE À L'USURE.
- 4 LAME RENFORCEE**
BOUCLERS HB400 EN FUSION PLACÉS SUR LES PARTIES LES PLUS EXPOSÉES, JUSQU'À 10 TONNES.
LAME EN HB400 POUR GODETS EXCÉDANT 10 TONNES.

EN OPTION

- 5 LAME SUPPLÉMENTAIRE**
INSTALLÉE SUR LE PORTE-DENTS. CETTE CONFIGURATION PERMET DES OPERATIONS D'INSTALLATION/DÉSINSTALLATION PLUS AISÉES EN ASSURANT UNE RÉSISTANCE ACCRUE AU SYSTÈME.

MOD.	MIDI							EXCAVATOR			
	SB38	SB45	SB53	SB62	SB67	SB73	SB80	SB85	SB92 HD	SB100 HD	SB110 HD
TONS	1,2 - 1,8	1,8 - 2,5	2,5 - 4,0	4,0 - 5,0	5,0 - 7,5	7,5 - 10,0	10,0 - 12,0	12,0 - 14,0	12,0 - 14,0	14,0 - 18,0	18,0 - 22,0

SB38 POIDS MACHINE 1,2 - 1,8

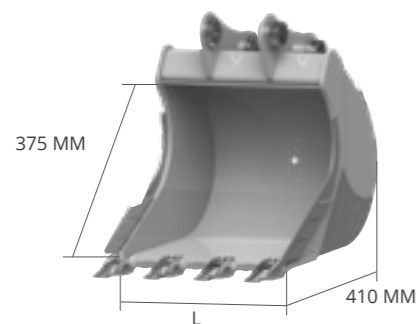
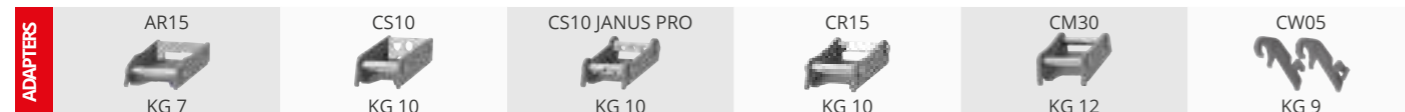

L MM	POIDS KG*	CAP. SAE L	DENTS N°	ADAPTERS
200	17	15	2	AF - AR - CS
				CR - CM
				CW - CS JANUS PRO
250	19	20	DF2 DC3 DE3	AF - AR - CS
				CR - CM
				CW - CS JANUS PRO
300	22	25	3	AF - AR - CS
				CR - CM
				CW - CS JANUS PRO
350	24	31	3	AF - AR - CS
				CR - CM
				CW - CS JANUS PRO
400	28	37	3	AF - AR - CS
				CR - CM
				CW - CS JANUS PRO
450	31	43	3	AF - AR - CS
				CR - CM
				CW - CS JANUS PRO
500	35	49	4	AF - AR - CS
				CR - CM
				CW - CS JANUS PRO
600	39	61	4	AF - AR - CS
				CR - CM
				CW - CS JANUS PRO
700	44	74	5	AF - AR - CS
				CR - CM
				CW - CS JANUS PRO

* poids cuve sans attache

SB45 POIDS MACHINE 1,8 - 2,5

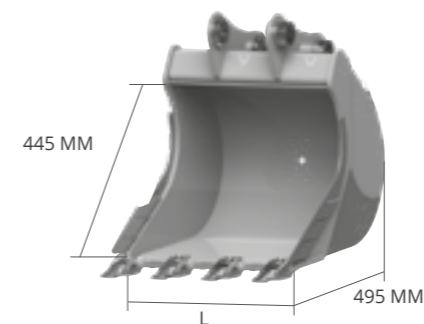
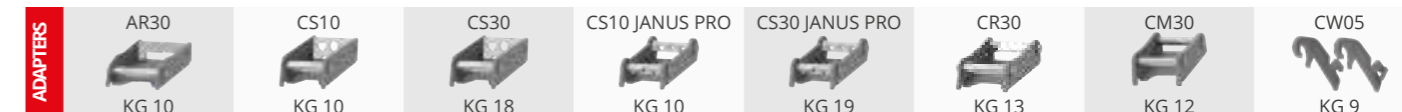

L MM	POIDS KG*	CAP. SAE L	DENTS N°	ADAPTERS
250	26	25	DF2 DC3 DE3	AF - AR - CS
				CR - CM
				CW - CS JANUS PRO
300	29	33	3	AF - AR - CS
				CR - CM
				CW - CS JANUS PRO
350	32	40	3	AF - AR - CS
				CR - CM
				CW - CS JANUS PRO
400	36	48	3	AF - AR - CS
				CR - CM
				CW - CS JANUS PRO
450	39	56	3	AF - AR - CS
				CR - CM
				CW - CS JANUS PRO
500	43	65	4	AF - AR - CS
				CR - CM
				CW - CS JANUS PRO
600	50	82	4	AF - AR - CS
				CR - CM
				CW - CS JANUS PRO
700	56	100	5	AF - AR - CS
				CR - CM
				CW - CS JANUS PRO
800	65	117	5	AF - AR - CS
				CR - CM
				CW - CS JANUS PRO

* poids cuve sans attache

EN OPTION

5
LAME SUPPLÉMENTAIRE

EN OPTION

5
LAME SUPPLÉMENTAIRE

SB53 POIDS MACHINE 2,5 - 4,0

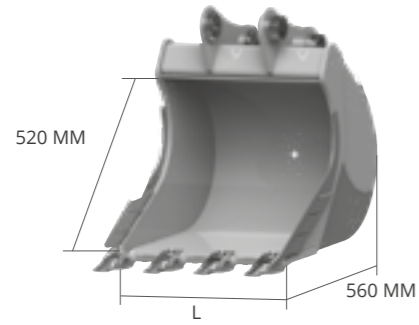
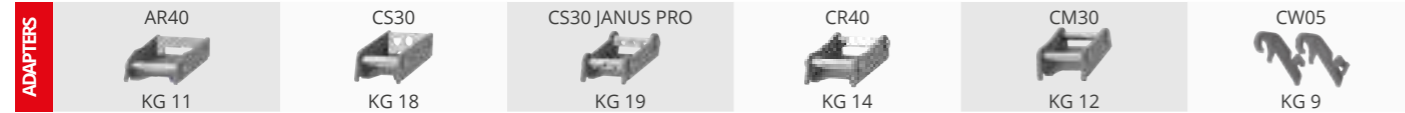

EN OPTION

5
LAME SUPPLÉMENTAIRE

L MM	POIDS KG*	CAP. SAE L	DENTS N°	ADAPTERS
250	37	32	2	AF - AR - CS
				CR - CM
				CW - CS JANUS PRO
300	40	41	3	AF - AR - CS
				CR - CM
				CW - CS JANUS PRO
350	46	51	3	AF - AR - CS
				CR - CM
				CW - CS JANUS PRO
400	51	61	3	AF - AR - CS
				CR - CM
				CW - CS JANUS PRO
450	55	72	3	AF - AR - CS
				CR - CM
				CW - CS JANUS PRO
500	59	82	4	AF - AR - CS
				CR - CM
				CW - CS JANUS PRO
600	67	105	4	AF - AR - CS
				CR - CM
				CW - CS JANUS PRO
700	76	127	5	AF - AR - CS
				CR - CM
				CW - CS JANUS PRO
800	85	152	5	AF - AR - CS
				CR - CM
				CW - CS JANUS PRO
900	93	175	5	AF - AR - CS
				CR - CM
				CW - CS JANUS PRO

* poids cuve sans attache

SB62 POIDS MACHINE 4,0 - 5,0

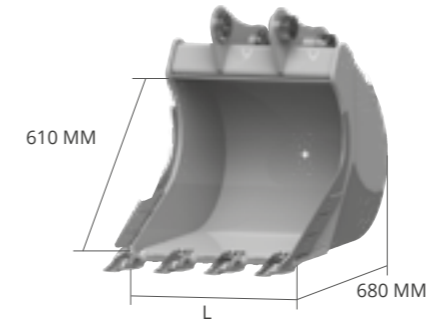
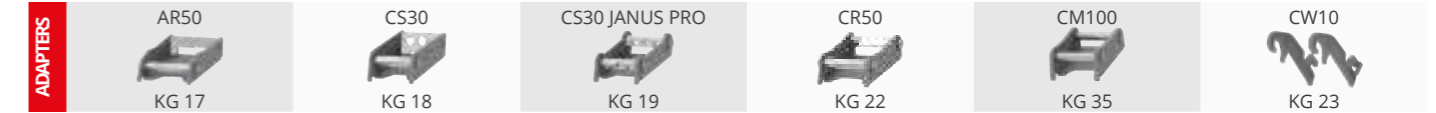

EN OPTION

5
LAME SUPPLÉMENTAIRE

L MM	POIDS KG*	CAP. SAE L	DENTS N°	ADAPTERS
250	57	45	2	AF - AR - CS
				CR - CM
				CW - CS JANUS PRO
300	63	58	3	AF - AR - CS
				CR - CM
				CW - CS JANUS PRO
350	68	71	3	AF - AR - CS
				CR - CM
				CW - CS JANUS PRO
400	74	85	3	AF - AR - CS
				CR - CM
				CW - CS JANUS PRO
450	79	100	3	AF - AR - CS
				CR - CM
				CW - CS JANUS PRO
500	86	115	4	AF - AR - CS
				CR - CM
				CW - CS JANUS PRO
600	97	147	4	AF - AR - CS
				CR - CM
				CW - CS JANUS PRO
700	109	180	5	AF - AR - CS
				CR - CM
				CW - CS JANUS PRO
800	121	213	5	AF - AR - CS
				CR - CM
				CW - CS JANUS PRO
900	133	248	6	AF - AR - CS
				CR - CM
				CW - CS JANUS PRO
1000	145	282	6	AF - AR - CS
				CR - CM
				CW - CS JANUS PRO

* poids cuve sans attache

SB67 POIDS MACHINE 5,0 - 7,5

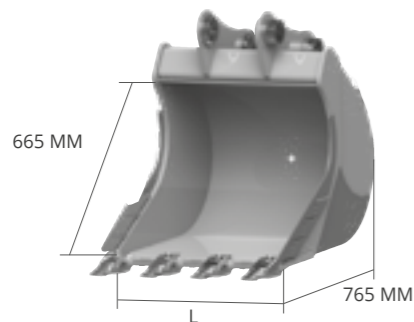
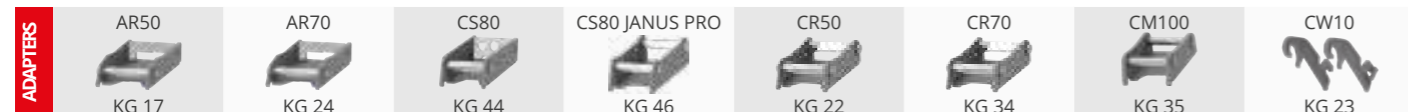

EN OPTION

5
LAME SUPPLÉMENTAIRE

L MM	POIDS KG*	CAP. SAE L	DENTS N°	ADAPTERS
300	83	68	3	AF - AR - CS
				CR - CM
				CW - CS JANUS PRO
350	92	84	3	AF - AR - CS
				CR - CM
				CW - CS JANUS PRO
400	101	101	3	AF - AR - CS
				CR - CM
				CW - CS JANUS PRO
450	109	118	3	AF - AR - CS
				CR - CM
				CW - CS JANUS PRO
500	117	137	4	AF - AR - CS
				CR - CM
				CW - CS JANUS PRO
600	134	174	4	AF - AR - CS
				CR - CM
				CW - CS JANUS PRO
700	150	214	5	AF - AR - CS
				CR - CM
				CW - CS JANUS PRO
800	167	254	5	AF - AR - CS
				CR - CM
				CW - CS JANUS PRO
900	183	295	6	AF - AR - CS
				CR - CM
				CW - CS JANUS PRO
1000	199	338	6	AF - AR - CS
				CR - CM
				CW - CS JANUS PRO

* poids cuve sans attache

SB73 POIDS MACHINE 7,5 - 10,0

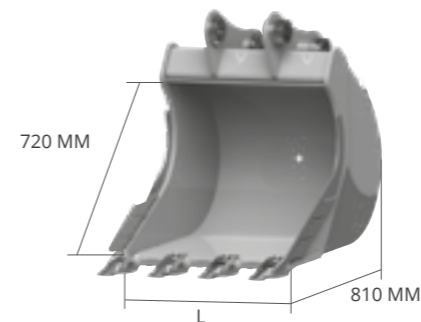

EN OPTION

5
LAME SUPPLÉMENTAIRE

L MM	POIDS KG*	CAP. SAE L	DENTS N°	ADAPTERS
300	95	76	2	AF - CS
				CR - CM
				CW - CS JANUS PRO
350	103	94	3	AF - CS
				CR - CM
				CW - CS JANUS PRO
400	110	113	3	AF - CS
				CR - CM
				CW - CS JANUS PRO
450	120	133	3	AF - CS
				CR - CM
				CW - CS JANUS PRO
500	130	153	3	AF - CS
				CR - CM
				CW - CS JANUS PRO
600	148	196	4	AF - CS
				CR - CM
				CW - CS JANUS PRO
700	166	240	4	AF - CS
				CR - CM
				CW - CS JANUS PRO
800	184	286	5	AF - CS
				CR - CM
				CW - CS JANUS PRO
900	202	333	5	AF - CS
				CR - CM
				CW - CS JANUS PRO
1000	220	379	5	AF - CS
				CR - CM
				CW - CS JANUS PRO
1100	238	430	5	AF - CS
				CR - CM
				CW - CS JANUS PRO

* poids cuve sans attache

SB80 SC80 POIDS MACHINE 10,0 - 12,0

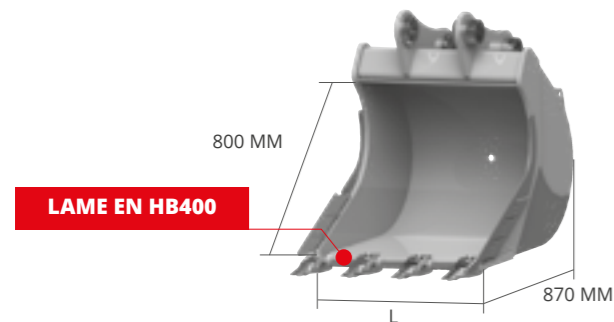

EN OPTION

L MM	POIDS KG*	CAP. SAE L	DENTS N°	ADAPTERS
300	119	86	2	AF - CS
				CR - CM - CS JANUS PRO
				CW
350	128	107	3	AF - CS
				CR - CM - CS JANUS PRO
				CW
400	141	129	3	AF - CS
				CR - CM - CS JANUS PRO
				CW
450	151	151	3	AF - CS
				CR - CM - CS JANUS PRO
				CW
500	162	174	3	AF - CS
				CR - CM - CS JANUS PRO
				CW
600	182	222	4	AF - CS
				CR - CM - CS JANUS PRO
				CW
700	203	273	4	AF - CS
				CR - CM - CS JANUS PRO
				CW
800	222	325	5	AF - CS
				CR - CM - CS JANUS PRO
				CW
900	242	379	5	AF - CS
				CR - CM - CS JANUS PRO
				CW
1000	261	433	5	AF - CS
				CR - CM - CS JANUS PRO
				CW
1100	282	486	5	AF - CS
				CR - CM - CS JANUS PRO
				CW
1200	303	546	6	AF - CS
				CR - CM - CS JANUS PRO
				CW
1300	323	602	6	AF - CS
				CR - CM - CS JANUS PRO
				CW

* poids cuve sans attache

SB85 MIDI POIDS MACHINE 12,0 - 14,0

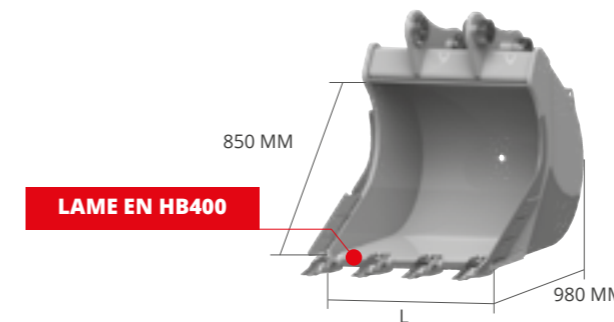
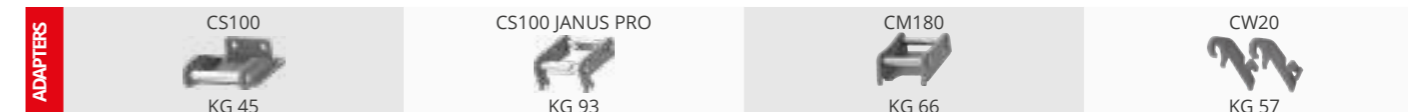

EN OPTION

L MM	POIDS KG*	CAP. SAE L	DENTS N°	ADAPTERS
400	197	171	3	AF - CM
				CS - CW
				CS JANUS PRO
500	220	235	3	AF - CM
				CS - CW
				CS JANUS PRO
600	243	300	4	AF - CM
				CS - CW
				CS JANUS PRO
700	266	368	4	AF - CM
				CS - CW
				CS JANUS PRO
800	289	438	5	AF - CM
				CS - CW
				CS JANUS PRO
900	312	510	5	AF - CM
				CS - CW
				CS JANUS PRO
1000	336	584	5	AF - CM
				CS - CW
				CS JANUS PRO
1100	360	657	5	AF - CM
				CS - CW
				CS JANUS PRO
1200	384	730	6	AF - CM
				CS - CW
				CS JANUS PRO
1300	408	810	6	AF - CM
				CS - CW
				CS JANUS PRO

* poids cuve sans attache

SB92 HD EXCAVATOR POIDS MACHINE 12,0 - 14,0

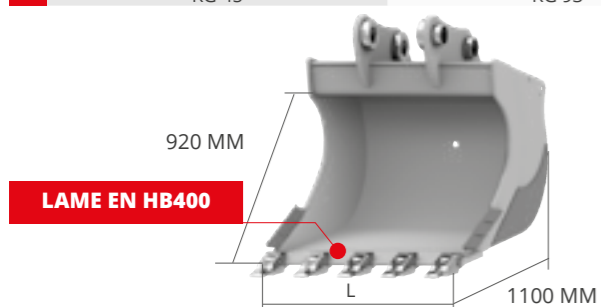
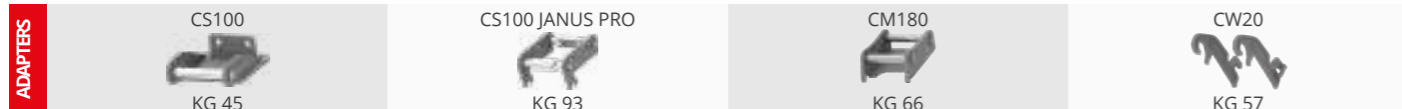

L MM	POIDS KG*	CAP. SAE L	DENTS N°	ADAPTERS
600	259	337	4	AF - CM
				CS - CW
				CS JANUS PRO
700	280	405	4	AF - CM
				CS - CW
				CS JANUS PRO
800	315	475	4	AF - CM
				CS - CW
				CS JANUS PRO
900	350	547	5	AF - CM
				CS - CW
				CS JANUS PRO
1000	385	622	5	AF - CM
				CS - CW
				CS JANUS PRO
1200	421	783	6	AF - CM
				CS - CW
				CS JANUS PRO

EN OPTION

5
LAME SUPPLÉMENTAIRE

SB100 HD POIDS MACHINE 14,0 - 18,0

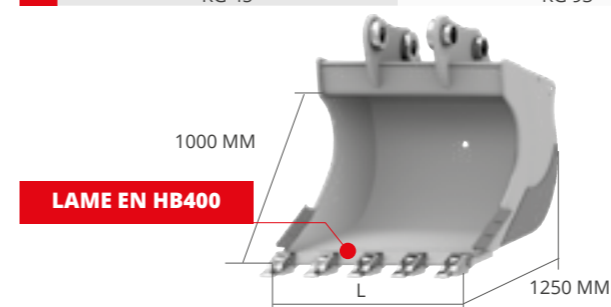
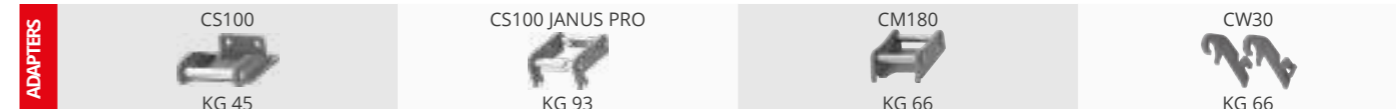

L MM	POIDS KG*	CAP. SAE L	DENTS N°	ADAPTERS
600	346	398	3	AF - CM
				CS - CW
				CS JANUS PRO
700	386	478	4	AF - CM
				CS - CW
				CS JANUS PRO
800	426	560	4	AF - CM
				CS - CW
				CS JANUS PRO
900	466	644	4	AF - CM
				CS - CW
				CS JANUS PRO
1000	506	730	5	AF - CM
				CS - CW
				CS JANUS PRO
1200	586	909	5	AF - CM
				CS - CW
				CS JANUS PRO

EN OPTION

5
LAME SUPPLÉMENTAIRE

SB110 HD POIDS MACHINE 18,0 - 22,0

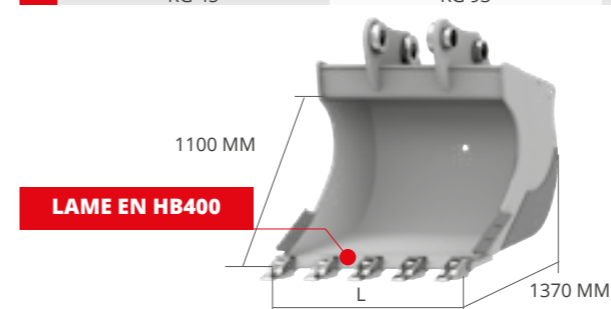

L MM	POIDS KG*	CAP. SAE L	DENTS N°	ADAPTERS
600	437	464	3	AF - CM
				CS - CW
				CS JANUS PRO
800	539	654	4	AF - CM
				CS - CW
				CS JANUS PRO
1000	641	854	5	AF - CM
				CS - CW
				CS JANUS PRO
1200	743	1064	5	AF - CM
				CS - CW
				CS JANUS PRO
1300	794	1173	6	AF - CM
				CS - CW
				CS JANUS PRO
1400	845	1288	6	AF - CM
				CS - CW
				CS JANUS PRO

EN OPTION

5
LAME SUPPLÉMENTAIRE

* poids cuve sans attache

* poids cuve sans attache



HB400

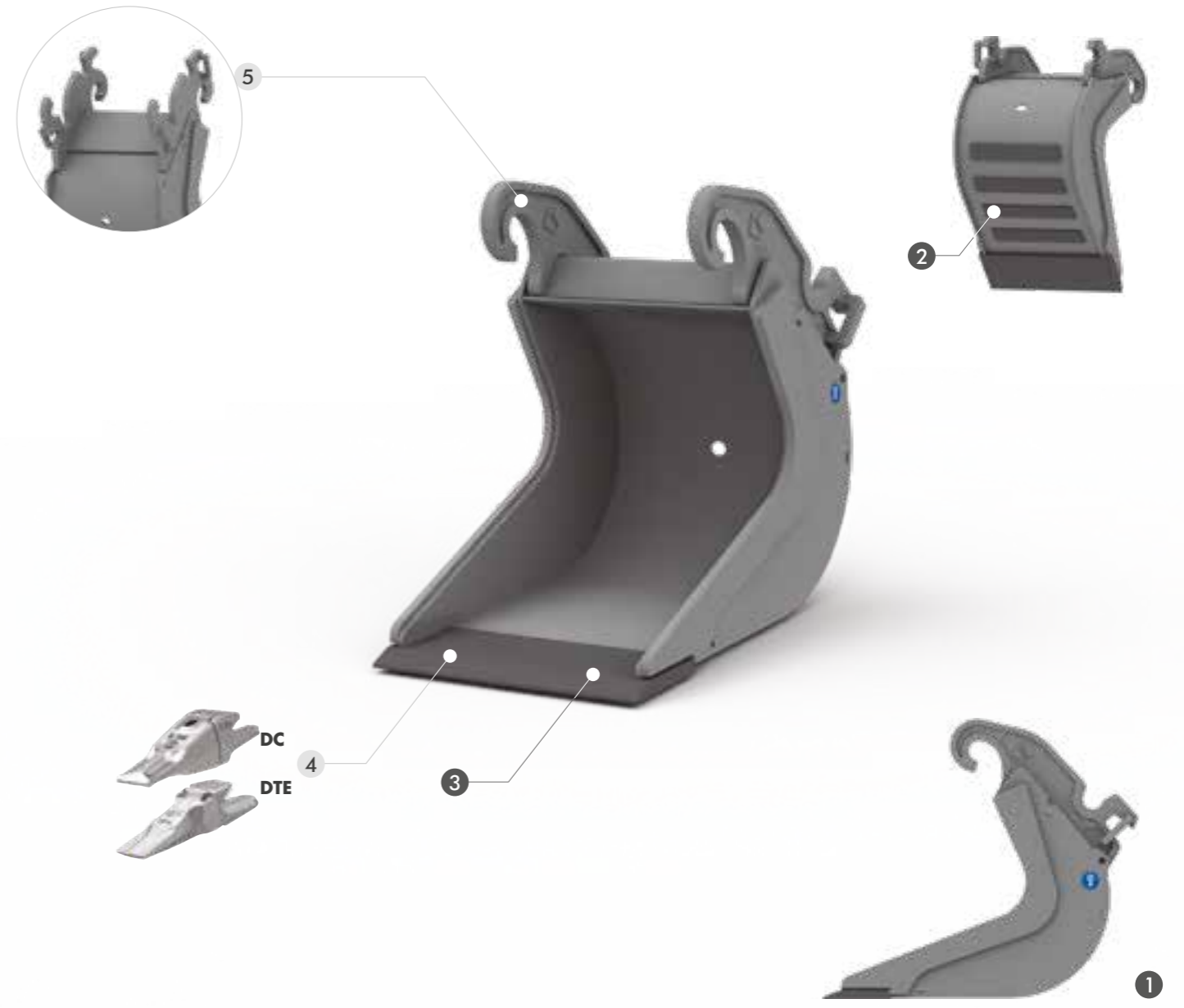

CHARACTERISTIQUES TECHNIQUES STANDARD

- 1 **PROFIL ALLONGÉ**
- 2 **BANDES DE RENFORCEMENT**
LES BANDES DE RENFORCEMENT HORIZONTALES PROTÈGENT LE FOND EN AUGMENTANT SA RÉSISTANCE À L'USURE.
- 3 **LAME EN HB400**

EN OPTION

- 4 **DENTS DC OU DENTS DTE**
- 5 **VERSION RÉVERSIBLE CW**
CET ADAPTEUR PERMET DE RENDRE LE GODET RÉVERSIBLE.

SA FORME ALLONGÉE EMPÊCHE QUE LE TERRAIN ADHÈRE AUX PAROIS LATÉRALES DU GODET ET FACILITE LE DECHARGEMENT DES MATÉRIAUX ARGILEUX ET MOUILLÉS. SES FLANCS ÉCHANCRÉS FACILITENT LES OPÉRATIONS EN PROXIMITÉ DES CONDUITES HYDRAULIQUES, DU GAZ, ETC. CE GODET EST DOTÉ DE LAME EN HB400.

MOD.	BN35	BN41	BN52	BN60	BN66	BN75	BN90
TONS	0,6 - 1,2	1,2 - 1,8	1,8 - 2,5	2,5 - 4,0	4,0 - 6,0	6,0 - 7,5	7,5 - 12,0

BN35 POIDS MACHINE 0,6 - 1,2

ADAPTERS

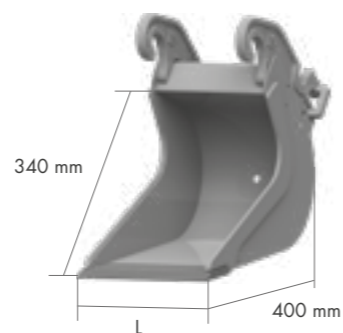

EN OPTION

4 4 5
Dents DC Dents DTE Version réversible CW

L mm	POIDS Kg*	CAP. SAE l	
220	17	16	AF
220	17	16	CW
250	18	18	AF
250	18	18	CW
300	20	22	AF
300	20	22	CW

BN41 POIDS MACHINE 1,2 - 1,8

ADAPTERS

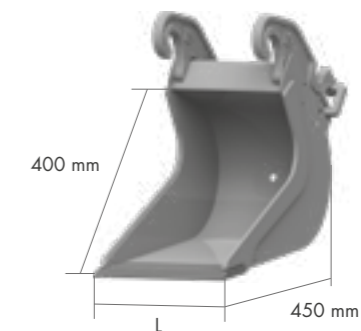

L mm	POIDS Kg*	CAP. SAE l	
220	19	20	AF
220	19	20	CW
250	20	23	AF
250	20	23	CW
300	22	28	AF
300	22	28	CW
350	24	34	AF
350	24	34	CW

EN OPTION

4 4 5
Dents DC Dents DTE Version réversible CW

BN52 POIDS MACHINE 1,8 - 2,5

ADAPTERS

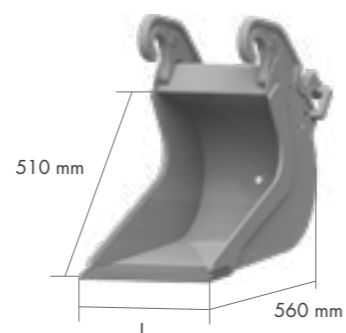

EN OPTION

4 4 5
Dents DC Dents DTE Version réversible CW

L mm	POIDS Kg*	CAP. SAE l	
220	25	27	AF
220	25	27	CW
250	27	32	AF
250	27	32	CW
300	29	38	AF
300	29	38	CW
350	33	46	AF
350	33	46	CW

BN60 POIDS MACHINE 2,5 - 4,0

ADAPTERS

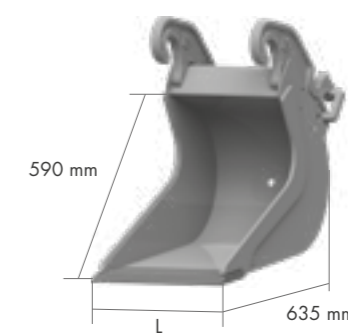
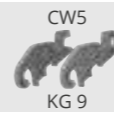

EN OPTION

4 4 5
Dents DC Dents DTE Version réversible CW

L mm	POIDS Kg*	CAP. SAE l	
220	31	38	AF
220	31	38	CW
250	33	45	AF
250	33	45	CW
300	36	53	AF
300	36	53	CW
350	40	65	AF
350	40	65	CW
400	44	77	AF
400	44	77	CW

* poids cuve sans attache

* poids cuve sans attache

BN66 POIDS MACHINE 4,0 - 6,0

ADAPTERS

CW10
KG 23

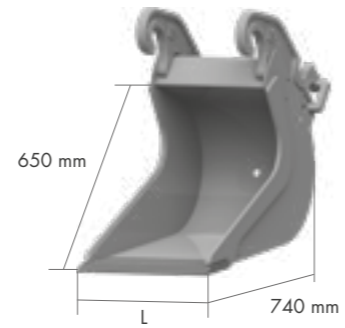

EN OPTION

4 4 5
Dents DC Dents DTE Version réversible CW

L mm	POIDS Kg*	CAP. SAE l	
220	39	42	AF
220	39	42	CW
250	42	50	AF
250	42	50	CW
300	48	77	AF
300	48	77	CW
350	51	83	AF
350	51	83	CW
400	56	92	AF
400	56	92	CW

BN75 POIDS MACHINE 6,0 - 7,5

ADAPTERS

CW10
KG 23

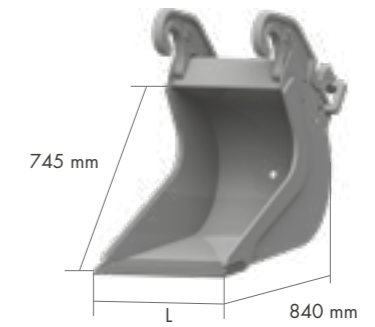

L mm	POIDS Kg*	CAP. SAE l	
250	67	59	AF
250	67	59	CW
300	71	74	AF
300	71	74	CW
350	73	91	AF
350	73	91	CW
400	74	106	AF
400	74	106	CW

EN OPTION

4 4 5
Dents DC Dents DTE Version réversible CW

BN90 POIDS MACHINE 7,5 - 12,0

ADAPTERS

CW10
KG 23

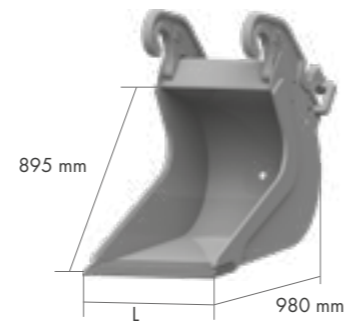

EN OPTION

4 4 5
Dents DC Dents DTE Version réversible CW

L mm	POIDS Kg*	CAP. SAE l	
300	90	78	AF
300	90	78	CW
350	96	100	AF
350	96	100	CW
400	100	123	AF
400	100	123	CW
450	106	146	AF
450	106	146	CW
500	115	171	AF
500	115	171	CW

* poids cuve sans attache

* poids cuve sans attache