

Bronto Skylift Insulated

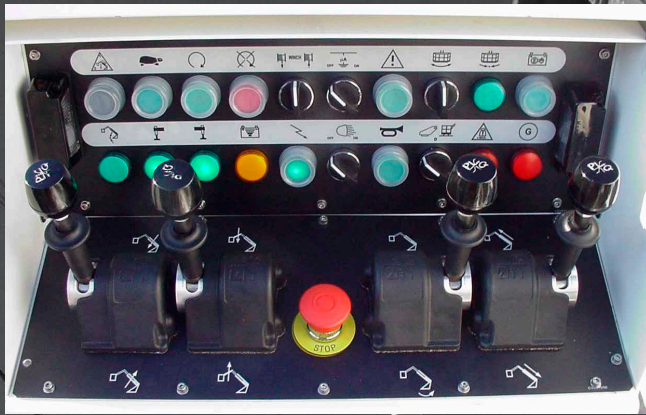



Extremely reliable and easy to use control system with precise movements.



Excellent approach angles and an efficient height to weight (GVW) ratio.



A sharp-edge corona ring provides a consistent voltage gradient along the length of the FRP boom.



Unmatched cage stability even at maximum heights.

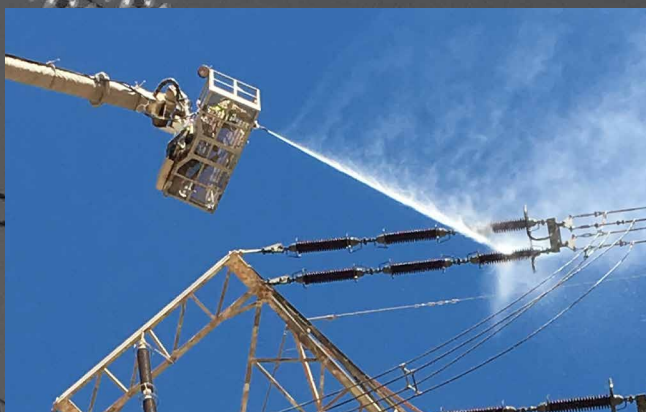

Pressurised waterline enables easy way to clean those insulators



Boom Leakage Detector indicates the actual current experienced by the platform personnel and FRP boom.

Live-line working at heights

We believe in continuous improvements, and are always aiming higher in our mission to provide the best solution for professionals working at height. The SI-HDT-C-range utilizes top class engineering for you to work safely and efficiently in electrifying environment.

SI insulated access platforms provide a safe, reliable and cost-effective way to reach energized overhead power lines. The high safe working load and winch capacity allows bare-hand maintenance of live-lines as well as any kind of heavy repair operations.

It's not only how high you can go, but also how safely you do it. And as always, your safety is of paramount importance. With Bronto Skylift platforms you can get where you need to be, and return home safely.









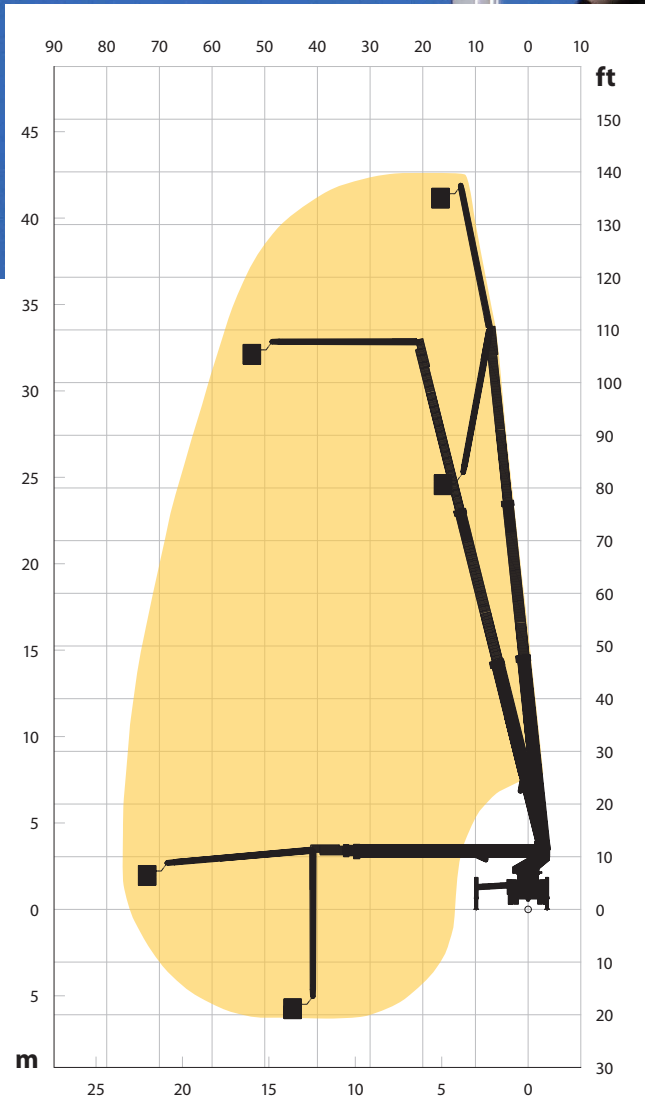

SI-HDT-C key features

- Designed for work at sub-transmission and transmission lines up to 765 kV
- Working height from 42 to 67 meters
- Working outreach up to 27 meters
- Combined cage and material handling load up to 800 kg
- Easy to use and precise Bronto+ control system
- Lifetime support to maintain high resale value



S1140HDT-C



- 
42 m
- 
75°
- 
24 m
- 
360°
- 
40 m
- 
4 m*
- 
450 kg
- 
13.5 m*
- 
0,9 x 2 m
- 
30 t*

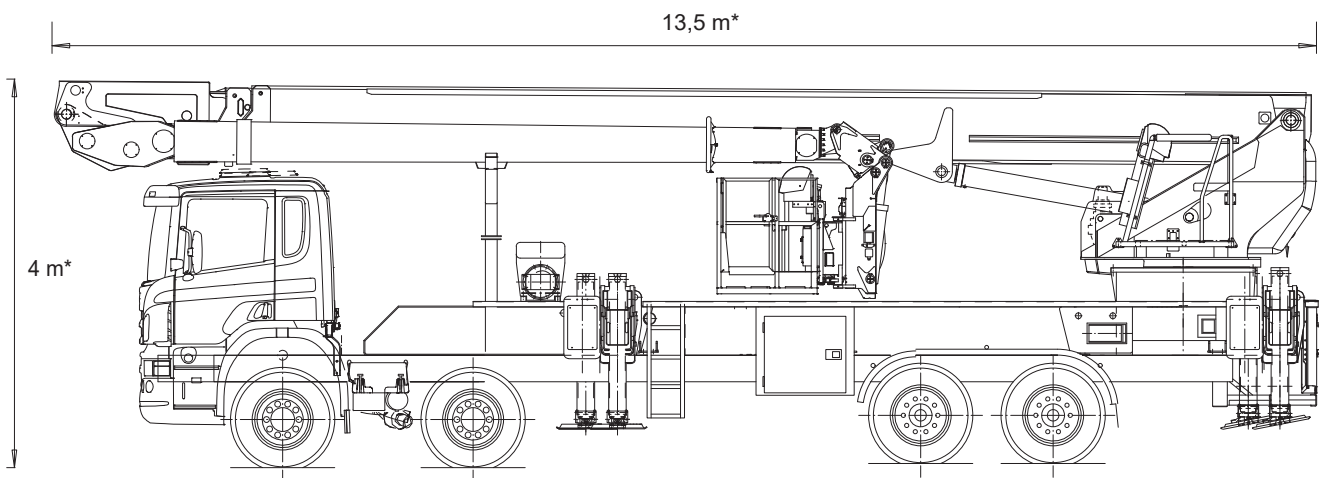

Diagrams and cage load presented with standard cage. Variations apply.
 * depending on chassis

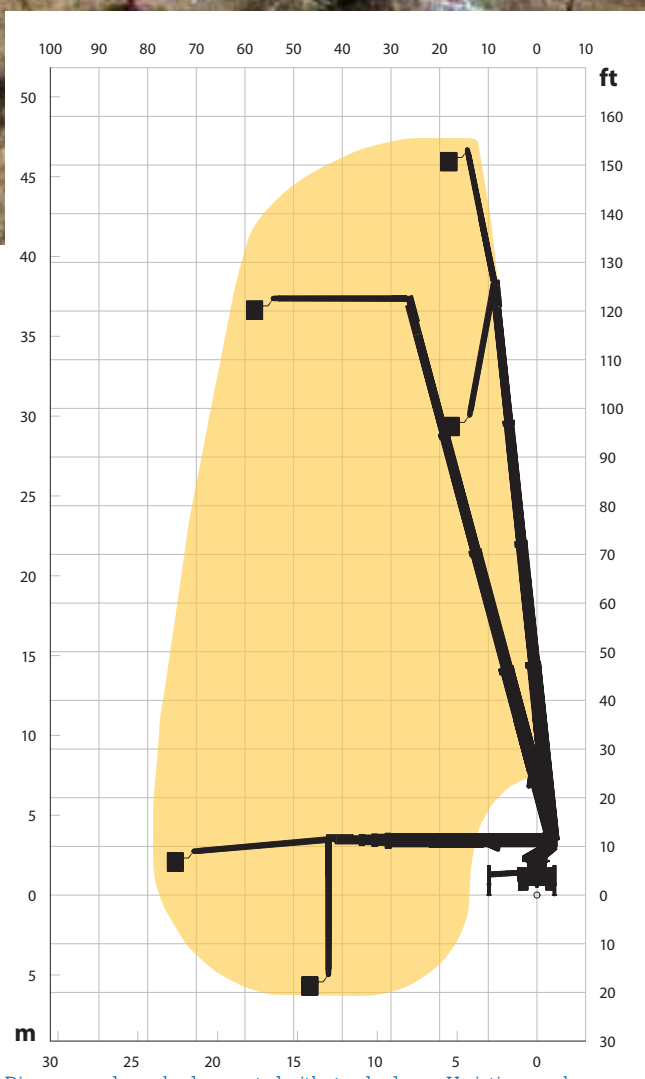

Drawing is with an example configuration and carrier for reference purpose only. Variations apply.

SI156HDT-C



- 
48 m
- 
75°
- 
24 m
- 
360°
- 
46 m
- 
4 m*
- 
450 kg
- 
13.5 m*
- 
0,9 x 2 m
- 
32 t*



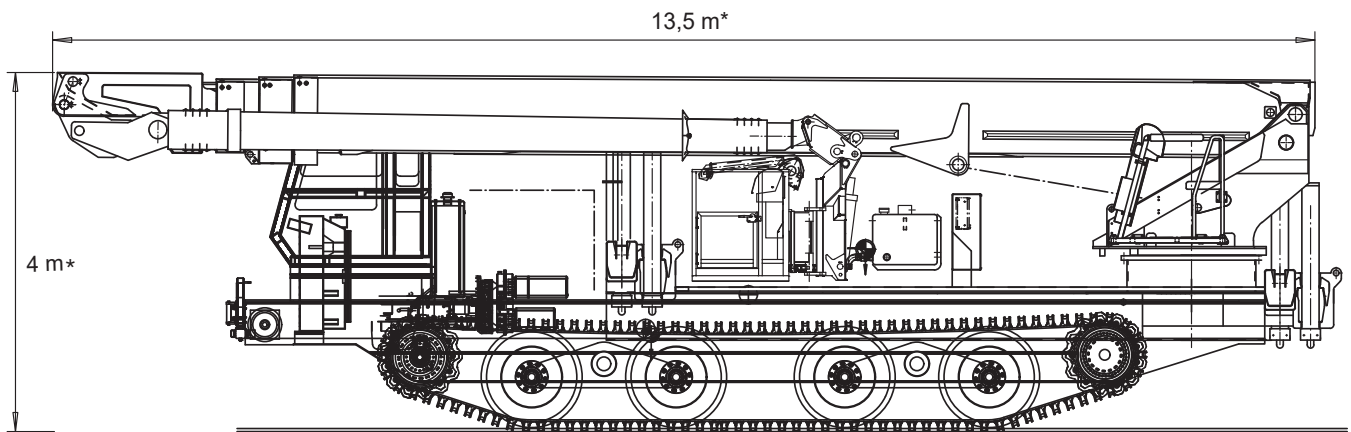





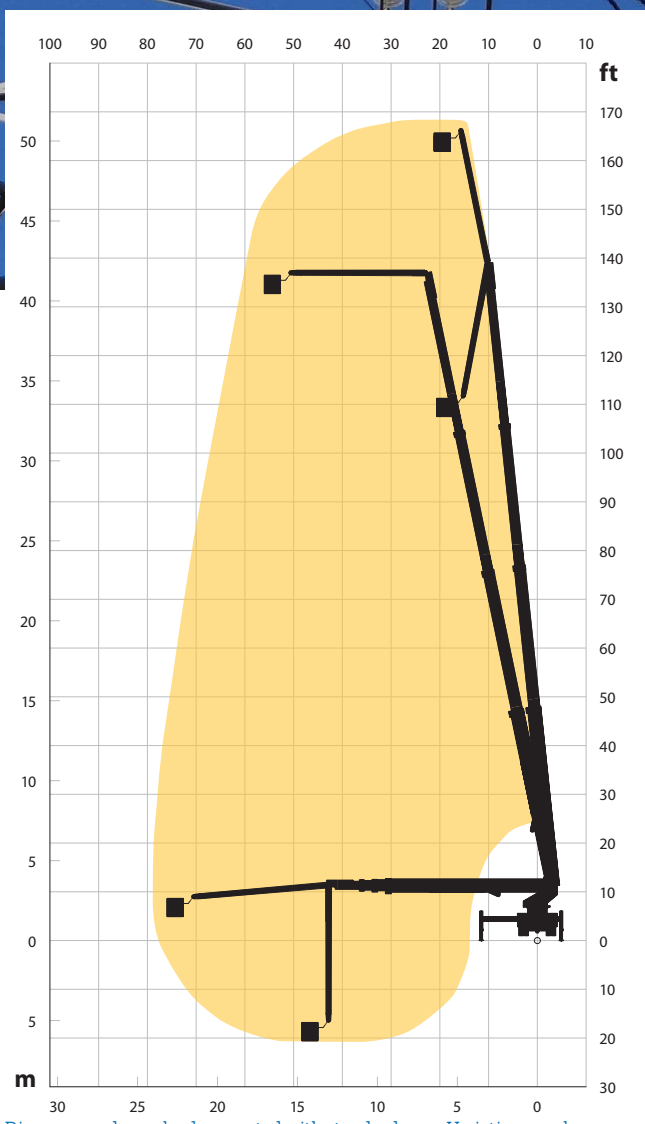

Diagrams and cage load presented with standard cage. Variations apply.
 * depending on chassis



Drawing is with an example configuration and carrier for reference purpose only. Variations apply.

SI169HDT-C



- 
51,5 m
- 
75°
- 
24 m
- 
360°
- 
49,5 m
- 
4 m*
- 
450 kg
- 
13,5 m*
- 
0,9 x 2 m
- 
32 t*



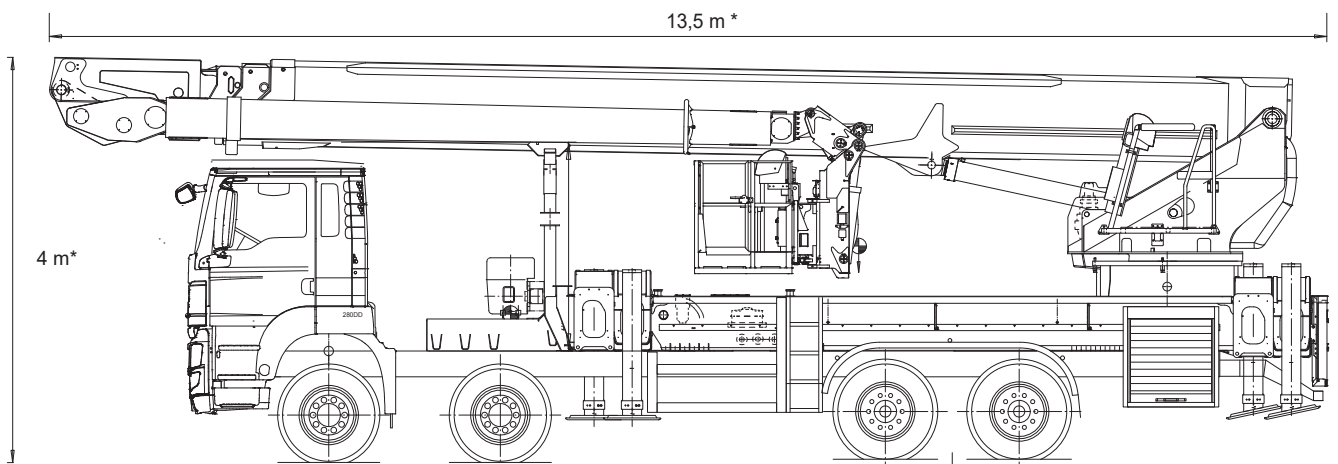





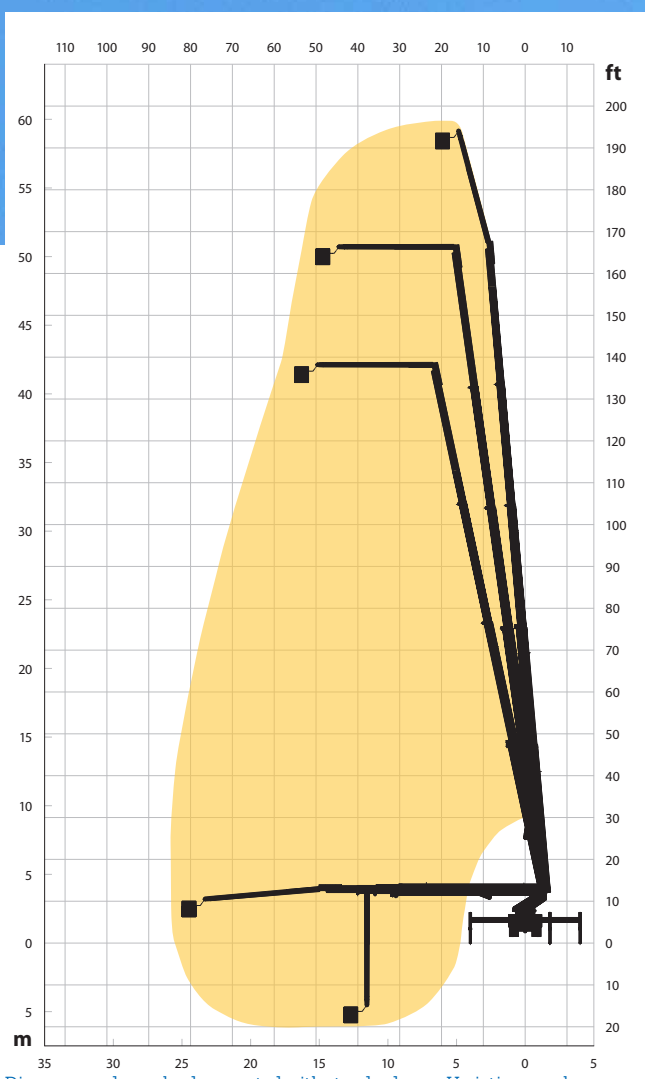
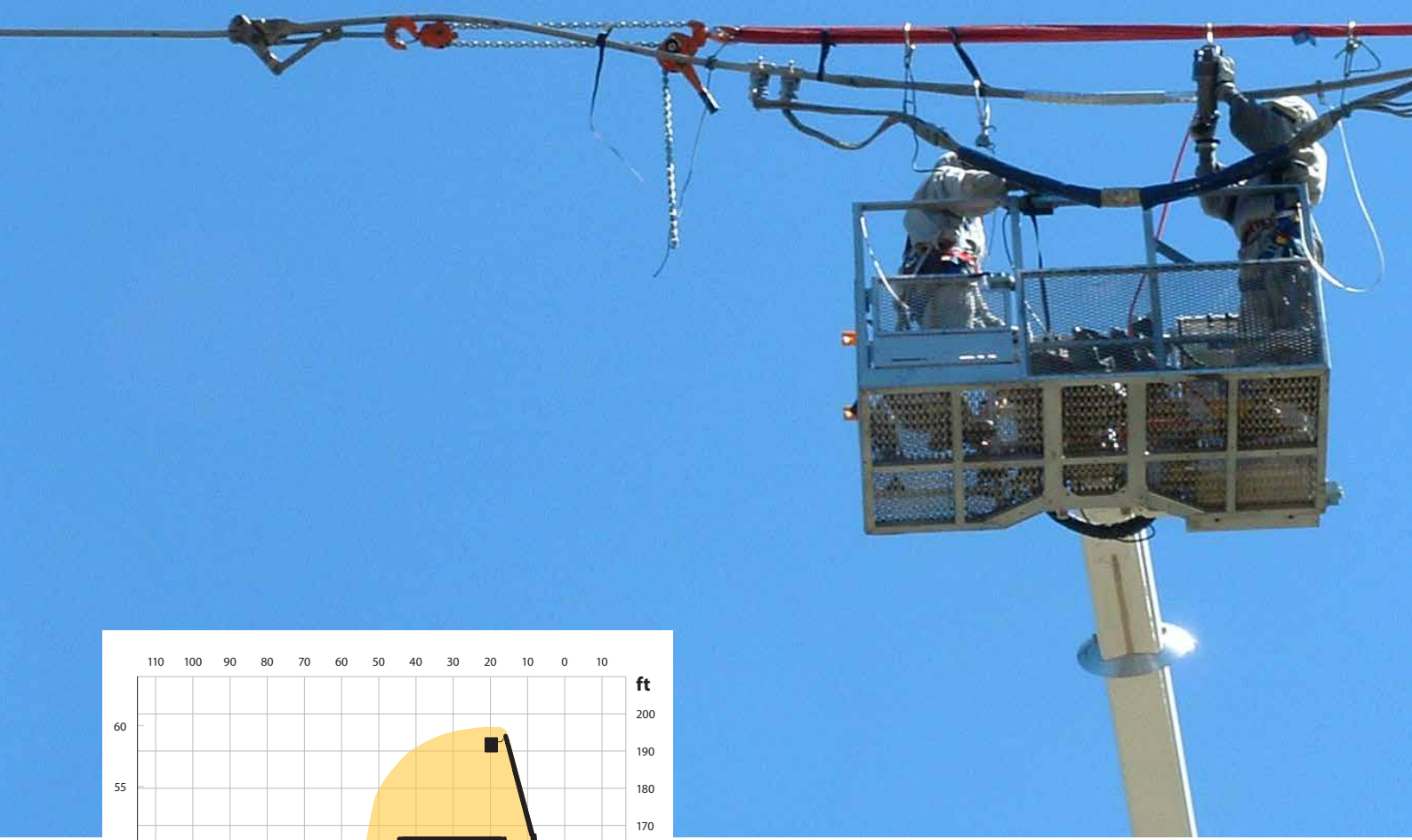

Diagrams and cage load presented with standard cage. Variations apply.
 * depending on chassis



Drawing is with an example configuration and carrier for reference purpose only. Variations apply.

SI196HDT-C



- 
60 m
- 
75°
- 
26 m
- 
360°
- 
58 m
- 
4,1 m*
- 
450 kg
- 
13,5 m*
- 
0,9 x 2 m
- 
36 t*

Diagrams and cage load presented with standard cage. Variations apply.
 * depending on chassis

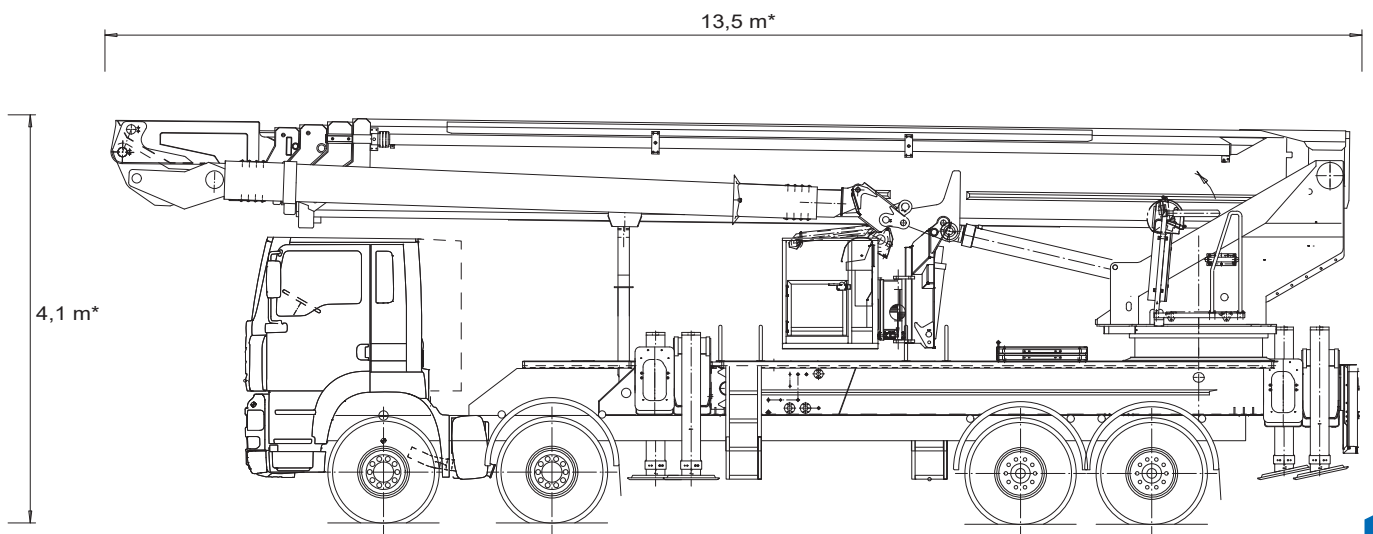
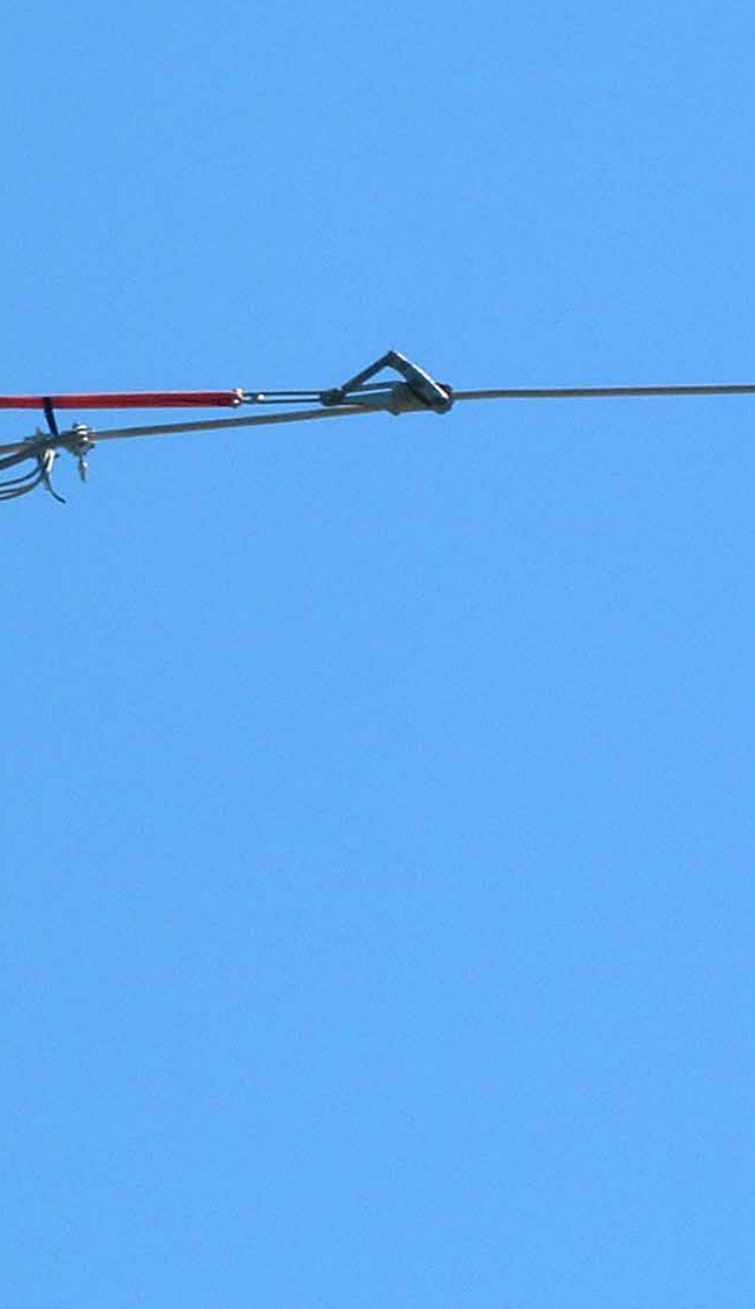

Drawing is with an example configuration and carrier for reference purpose only. Variations apply.

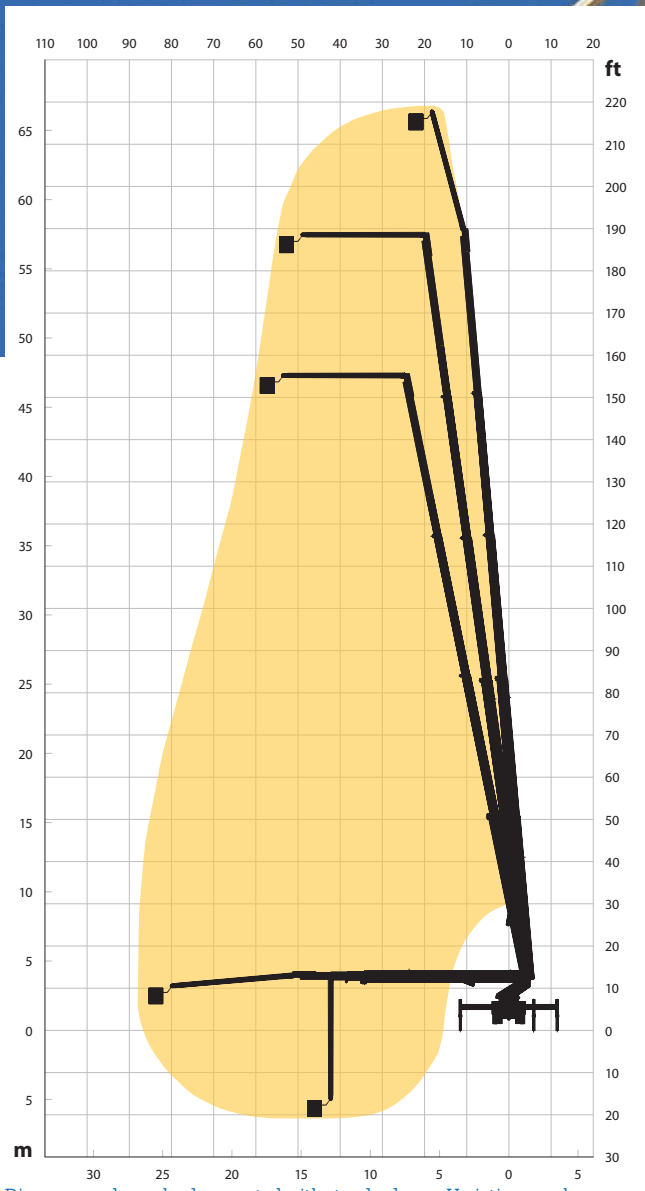
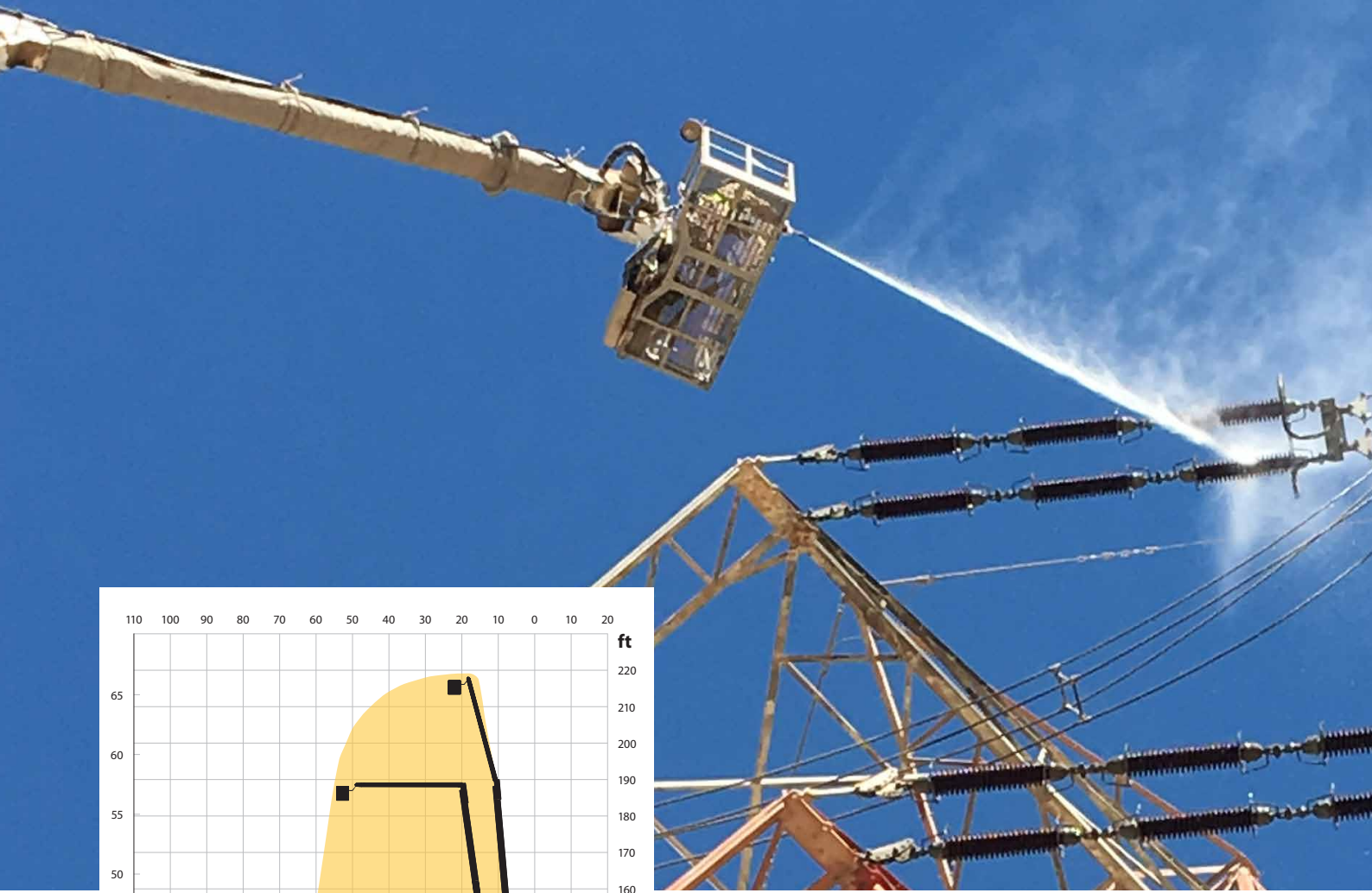

- 67 m**
- 75°**
- 27 m**
- 360°**
- 65 m**
- 4,1 m***
- 450 kg**
- 14,8 m***
- 0,9 x 2 m**
- 42 t***

Diagrams and cage load presented with standard cage. Variations apply.
 * depending on chassis

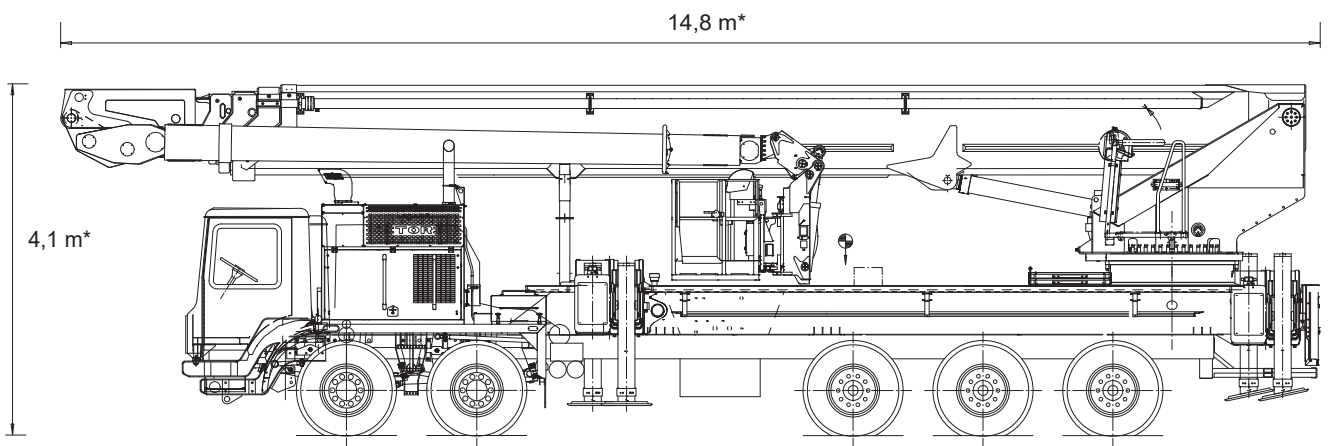
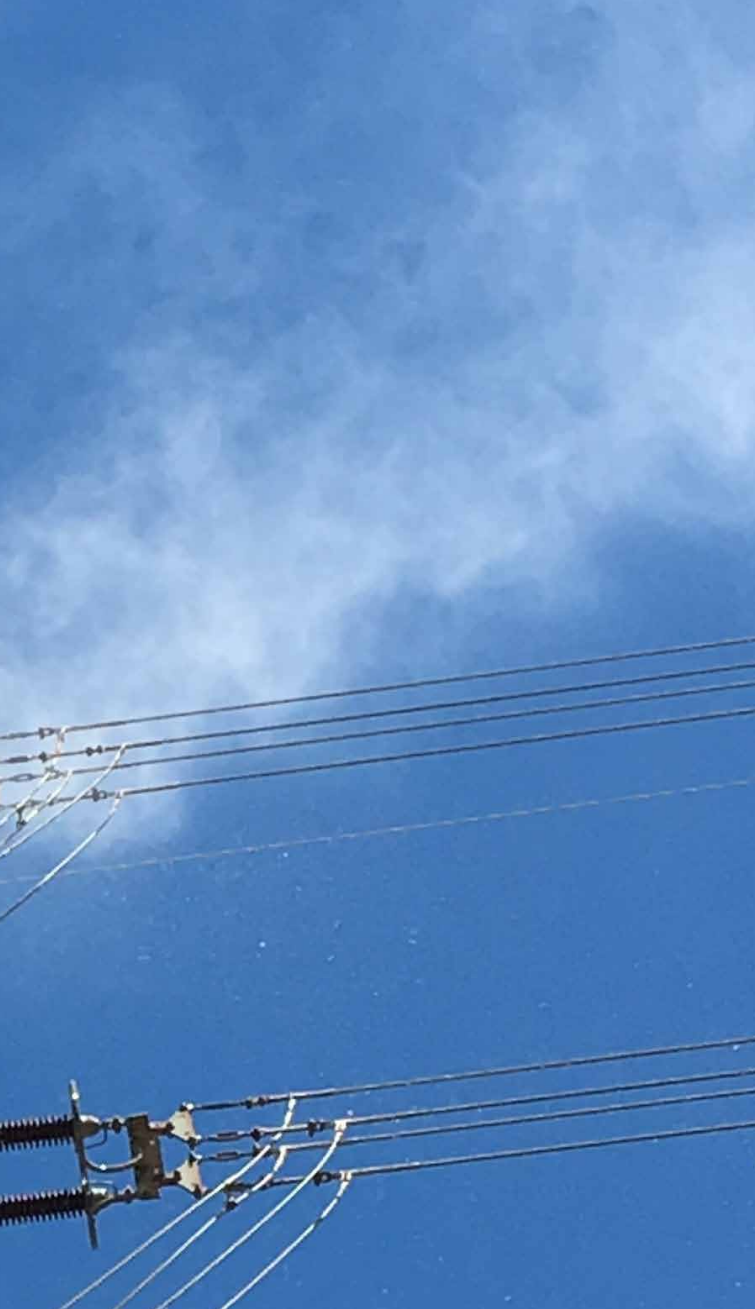

Drawing is with an example configuration and carrier for reference purpose only. Variations apply.



It's all about the uptime

With the Bronto Skylift service tools you can maximize your uptime and reduce maintenance cost.

We back you up

We want to keep your machines running with the best possible rate and keep their residual value. That's why we back you up from the first day through out the life cycle of your platform. When buying a new Bronto Skylift unit, you can trust that its spare parts are available for at least the next 25 years.

With the comprehensive training and service selection you can rest assured that your platforms are running at the best possible rate and keeping their residual value when it's time to renew your fleet. Widest service network in the industry keeps you backed up where ever you are.

Service agreements

With Bronto Service agreement, you can be assured that your Bronto equipment is kept in the best possible shape for its entire lifecycle. The content of our mutual agreement is fully customized according to your needs and wishes.

This covers the annual inspections and service visits, but it can also be expanded to include other services such as more detailed inspections, other maintenance activities, and spare parts.





Bronto Skylift is a trusted global supplier of truck-mounted hydraulic platforms. We design, manufacture, sell and service appliances for rescue and firefighting as well as for industrial access.

Our product range includes approximately 50 models with a range of 17 to 112 metres of working height. The advanced modularity also allows for numerous client-specific modifications. During the past 50 years, we have delivered over 7,000 platform units to fire brigades and industrial customers throughout all the continents in more than 120 countries.

Our headquarters and production plants are situated in Finland. We also have subsidiaries in Germany, Sweden, Switzerland and the US. The company is part of the Japan-based Morita Holdings Corporation.

sales@brontoskylift.com

Technical data and illustrations subject to change without notice.

www.brontoskylift.com