

Micropac Super Pbb
Micropac Super Pbb

The form fill & seal wrapper

This versatile horizontal form fill and seal machine is suitable for wrapping solid products with polypropylene or polyethylene films.

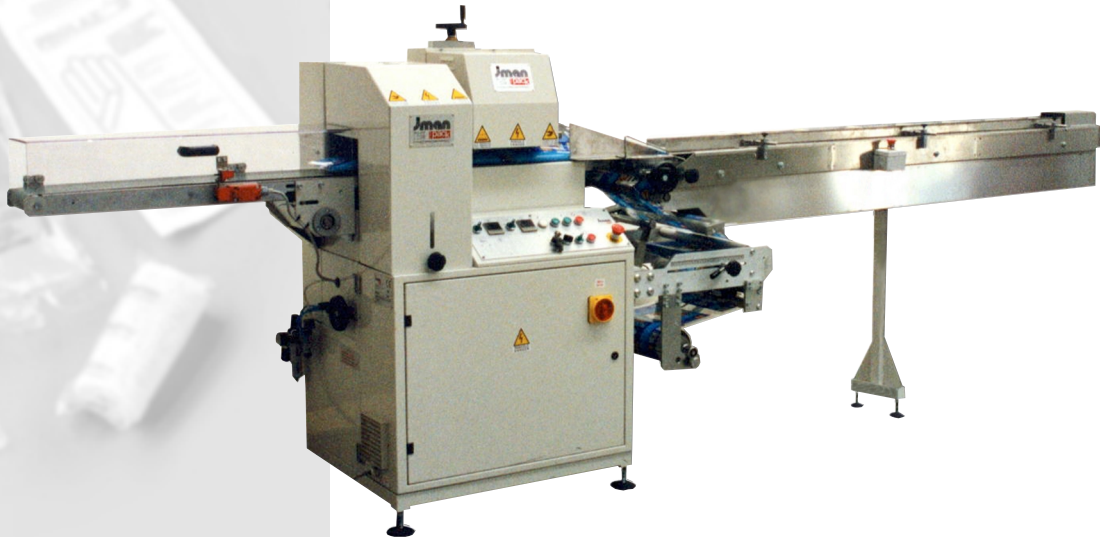

Product range:

Length: 100 to 500

Film length : 400 to 500 mm

Speed : up to 200 bag



Features and performances

- Main frame in steel construction
- Mechanical adjustable speed up to 200 bags/min.
- Longitudinal sealing assembly with two pairs of wheels
- Available with pre-heating wheels and pre-heating bars
- Rotative transversal sealing assembly provided with safety clutch
- Universal forming tunnel
- Sealing temperatures adjustable via temperature controllers
- Festo pneumatic components
- Available with many kinds of printer models
- Machine according to CE standards

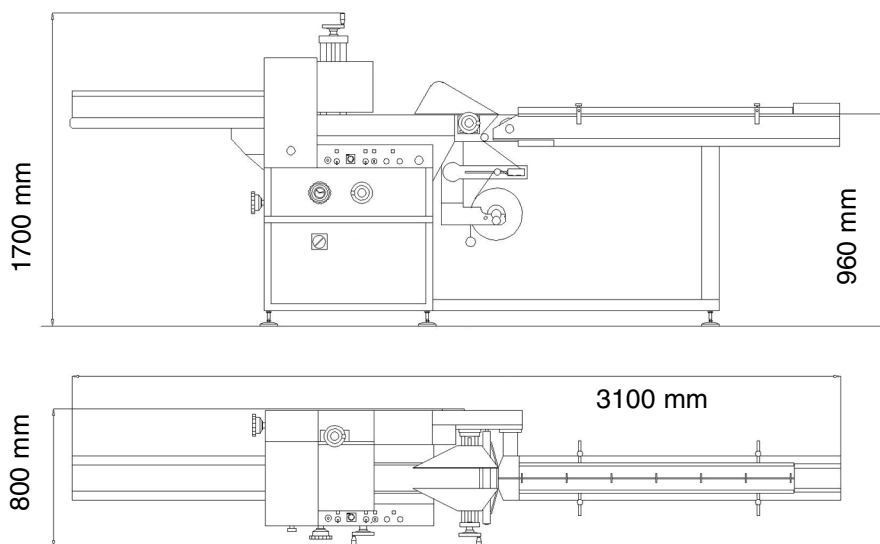

bottom film feed

also available:

Automatic feeding systems, labellers, printers and gas flushing systems.

imanpack
PACKAGING SOLUTIONS

Via lago di Bolsena, 19 36015 Schio (VI) ITALY
tel. +39.0445.578.811 fax +39.0445.575.111
www.imanpack.com info@imanpack.it