

Palatine

CARACTÉRISTIQUES MÉCANIQUES / MECHANICAL CHARACTERISTICS

Corps et dôme en aluminium injecté, miroir asymétrique, verre trempé plat.
 Body and dome in die cast aluminium, asymmetrical mirror, hardened flat glass.



Étanchéité / Protection : IP 66



Finition / Finish :
 Peinture polyester selon nuancier RAL
 Polyester paint according to RAL color chart



Poids / Weight : 6,90



Montage top ou suspendue / On top or hanging assembly :
 27 PG mâle / Male PG 27

Palatine est une lanterne classique de style rétro avec une technologie contemporaine. Une solution idéale pour un éclairage très efficace, respectueux des impératifs architecturaux, résidentiels et historiques.



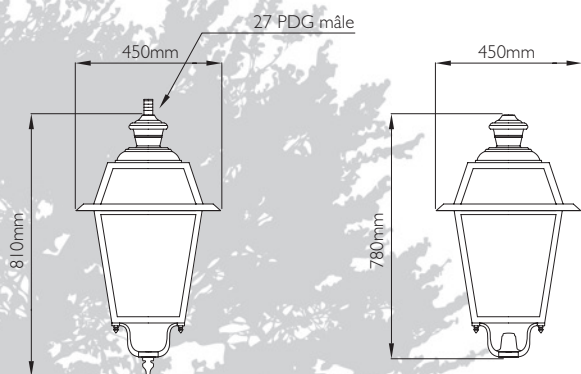

Palatine is a classic lantern of retro style with a contemporary technology. An ideal solution for a very effective lighting, respectful of the architectural, residential and historic imperatives.



CARACTÉRISTIQUES ÉLECTRIQUES / ELECTRICAL CHARACTERISTICS



Classe 2 / Class 2

Sodium Haute Pression 	Cosmo White 	Iodures Métalliques 	Éclairage LED 
70 - 100 W	45 - 60 - 90 W	70 - 100 W	40 - 60 W

