

THIS DRAWING IS THE PROPERTY OF ENERSYS LTD. IT IS SUPPLIED ON LOAN IN CONFIDENCE AND MUST BE RETURNED IMMEDIATELY ON REQUEST. NO PART OF THE DRAWING MAY BE COPIED OR REPRODUCED IN ANY WAY NOR MAY THE INFORMATION OR DESIGN DEPICTED BE DISCLOSED WITHOUT THE PRIOR WRITTEN CONSENT OF THE OWNER. ALL RIGHTS RESERVED.

REVISION			
REV	DESCRIPTION (MRA No.)	DATE	APPRVD.
00	First Drawn	05.02.07	R.Knight
00A	Draw. was Purchase Spec	24.05.11	R.Knight

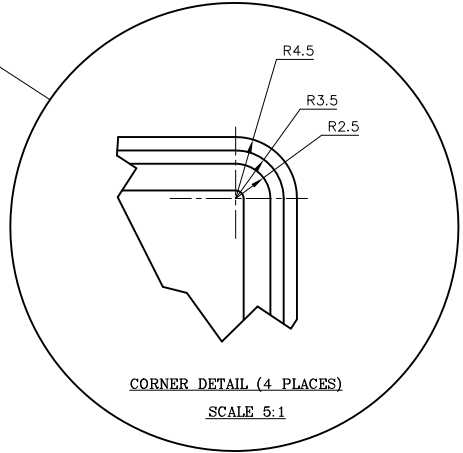
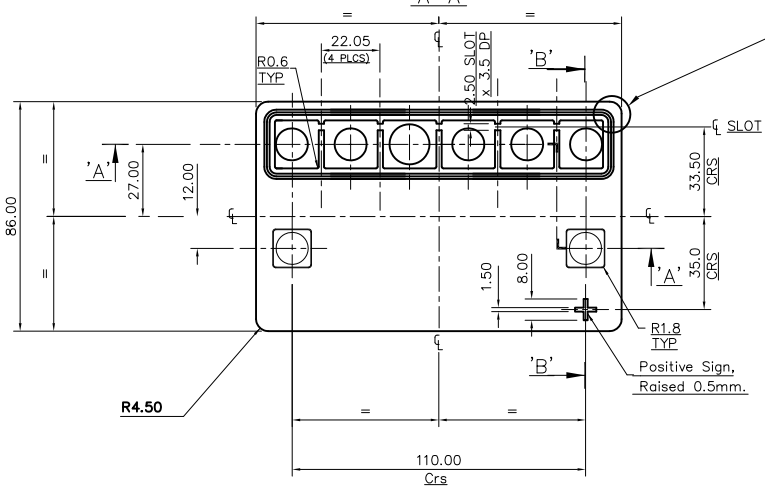
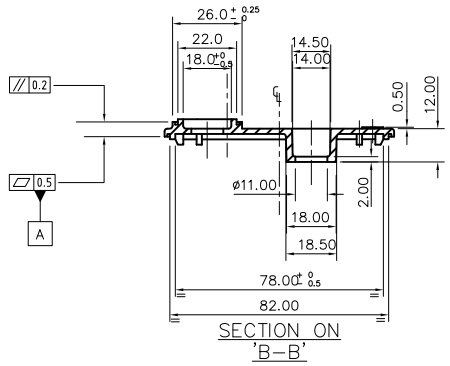
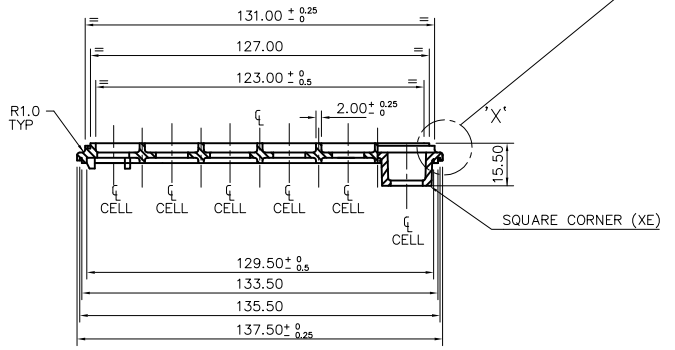
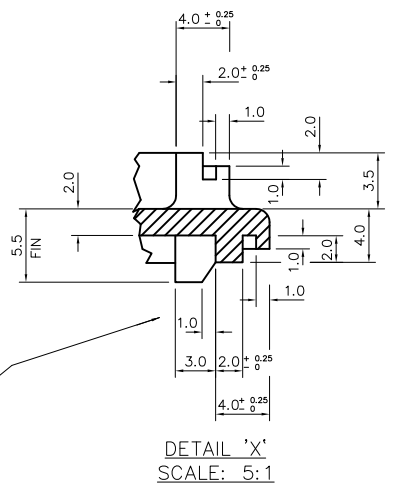
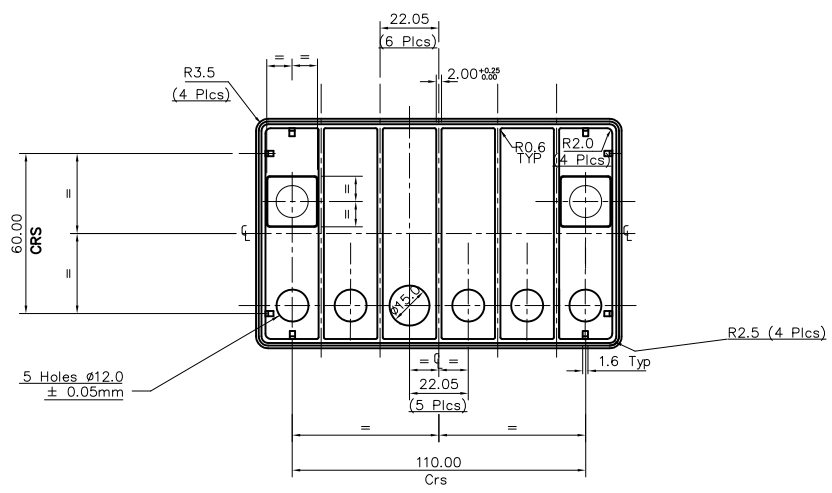

- NOTES:-**
- UNSPECIFIED RADII TO BE 0.25mm MAX.
 - DRAFT ANGLE 1° MAX, EXCEPT WHERE SPECIFIED.
 - COMPONENT TO BE FREE OF OIL AND OTHER CONTAMINANTS. A FLUOROCARBON MOULD RELEASE AGENT MAY BE USED BUT MUST BE COMPLETELY REMOVED PRIOR TO DELIVERY.
 - NO FLASH, SPRUE SHALL NOT PROTRUDE. VISIBLE SURFACES OF COMPONENT TO BE FREE FROM SCRATCHES.
 - PACKAGING:- COMPONENTS TO BE PLACED IN A SEALED PLASTIC BAG INSIDE SHIPPING CARTON, WHICH SHALL RESIST DAMAGE TO COMPONENTS.
 - CARTON INFORMATION TO INCLUDE:-
A. H.E.P.L. PART NO. & REVISION.
B. H.E.P.L. PURCHASE ORDER NO.
C. PART DESCRIPTION.
D. QUANTITY.
E. DATE OF MANUFACTURE & LOT NO.
 - NO DEVIATION SHALL BE MADE FROM THIS SPECIFICATION WITHOUT WRITTEN PERMISSION.
 - MATERIAL:- FLAME RETARDANT A.B.S. VE101
 - COLOUR:- PANTONE RED 485.
 - MOULD TO BE "ARMALLOY" COATED.
 - FOR INSPECTION REQUIREMENTS OF PRODUCTION MOULDINGS REFER TO TM16.

DRAWN: C.James CHECKED: C.James APPROVED: R.Knight MATERIAL: SEE NOTES TOLERANCES (U.G.S.): ANGULAR: ±0.5° DIMENSIONAL: ±0.25 (0.01") ALL DIMENSIONS IN mm ()	ENERSYS LTD. STEPHENSON STREET NEWPORT, SWALES NP10 4XJ TEL: (01483) 277873 FAX: (01483) 281787	TITLE: MONOLID, 5Ah / SBS 8. SIZE: A1 CAGE Code: U6335 DRG. No.: 2107-9121 REV: 00A SCALE: 1:1 SHEET No. 1 OF 1
---	---	---