

FOURS ENCASTRABLES ELECTRIQUES

simples ou doubles

LA SELECTION

F & U
Fourneaux & Ustensiles

Les fonctions



Convection naturelle

Cuisson traditionnelles, rôtir, cuisson longue basse température



Sole

Cuire les fonds de tartes, finir les quiches, pizza ...



Voûte

Gratiner, finir une cuisson, colorer



Cuisson intensive

Cuire pains, pâtisseries, pâtes à lever, contenu humecté...



Sole ventilée

idéal pour cuire les fonds de tartes, les quiches à fort contenu humide



Cuisson douce

Cuire délicatement, Mijoter, Réchauffer ...



Décongélation

Brasser l'air, accélérer la décongélation naturelle



Chaleur tournante pulsée

Pièces volumineuses (chaleur homogène), cuissons sur plusieurs niveaux



Four gaz à chauffe directe

Idéal pour la cuisson des viandes et volailles, sans dessèchement



GENUS

Méthode de cuisson brevetée permettant de cuire jusqu'à 4 fois plus rapidement.



Mijotage

Cuissons longues à basse température



Nettoyage vapeur



Gril standard

Puissance fixe pour tout type de grillades



Gril variable

Puissance ajustable via le thermostat du four



Maxigrill

Gril double (économique ou pleine largeur) à puissance variable. Le Maxigrill Vitro (MGV) est un foyer radiant placé sous une plaque vitrocéramique.



Gril ventilé

Gril rapide permettant de ne pas dessécher les mets délicats tels que filets de poisson, ventrèche, bacon...



Rôtisserie

Cuissons à la broche

Les caractéristiques spécifiques (selon modèle)



Slide&Clean

Intérieur de porte plein verre, amovible sans outil par simple coulissement

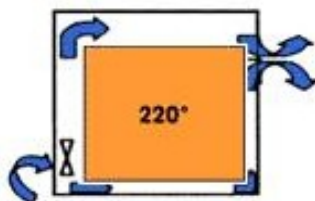

Powercool

Système de ventilation refroidissant le caisson ainsi que la porte du four afin de protéger le meuble et l'utilisateur.



Cavité hydroformée

Cavité moulée d'une seule pièce par pression d'eau, plus robuste et dépourvue d'angles difficiles à nettoyer.





 blanc

DEBUT - Four à convection naturelle

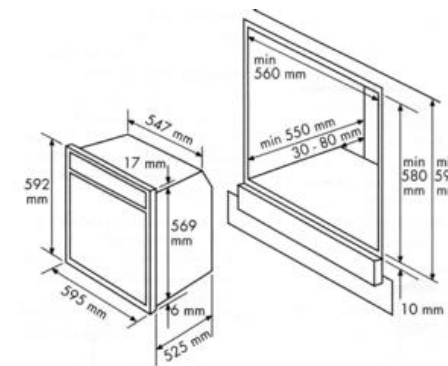

4 modes de cuisson
Cavité **hydroformée** (69 litres brut) : L470 x P420 x H350 mm
Les + : **Slide&Clean**
Alimentation 220-240V (1,9kW max.)



 inox
 noir

FE067 - Four à convection naturelle



4 modes de cuisson
Minuterie sonore
Cavité (55 litres brut) : L455 x P375 x H325 mm
Alimentation 220-240V (1,8kW max.)

kit catalyse disponible en option

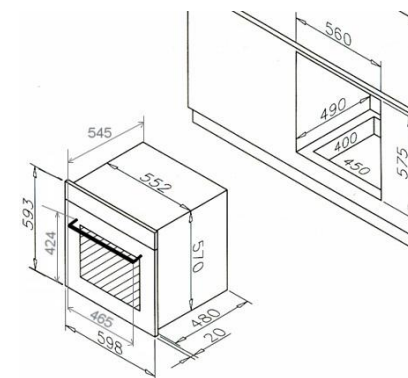

 blanc

FEA077 - Four à convection naturelle



4 modes de cuisson
Minuterie sonore
Cavité (55 litres brut) : L455 x P375 x H325 mm
Alimentation 220-240V (1,8kW max.)

kit catalyse disponible en option

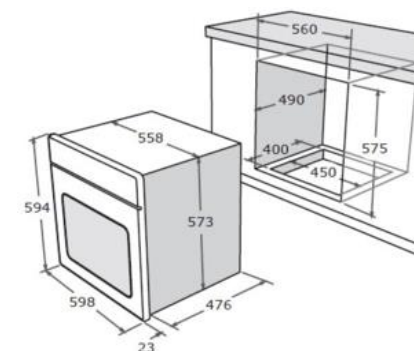



blanc

FE1614 - Four ventilé



4 modes de cuisson

Minuterie sonore

Cavité (53 litres brut) : L455 x P360 x H325 mm

Alimentation 220-240V (2,4kW max.)

kit catalyse disponible en option

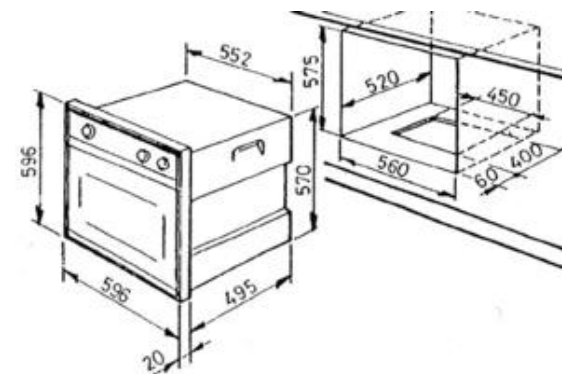



FE5608B - Four multifonction



5 modes de cuisson
Horloge + minuterie
Cavité (53 litres brut) : L455 x P360 x H325 mm
Les + : **façade bombée**
Alimentation 220-240V (1,9kW max.)

kit catalyse disponible en option

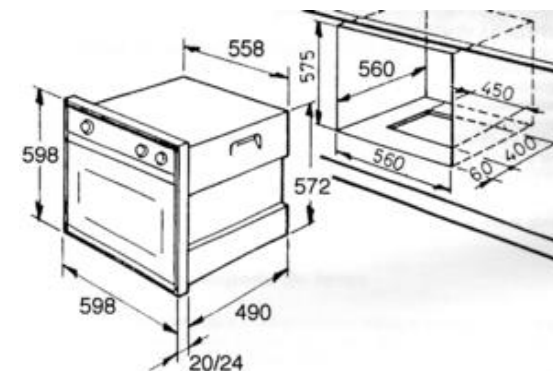

FE6603B - Four multifonction



5 modes de cuisson
Horloge + minuterie
Cavité (53 litres brut) : L455 x P360 x H325 mm
Les + : **façade bombée**
Alimentation 220-240V (1,9kW max.)

kit catalyse disponible en option

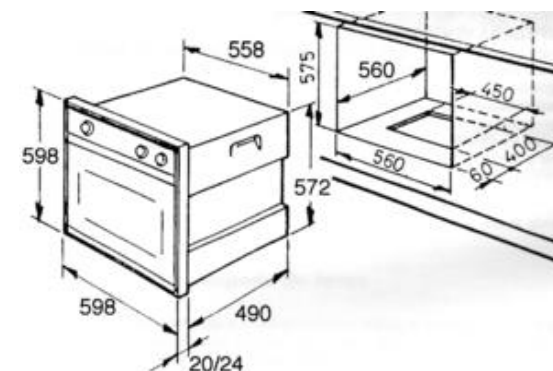

FE761 - Four multifonction



7 modes de cuisson
Programmateur digital
Cavité (53 litres brut) : L455 x P360 x H325 mm
Les + : **finition design « aluminium + miroir »**
Alimentation 220-240V (2,4kW max.)

kit catalyse disponible en option

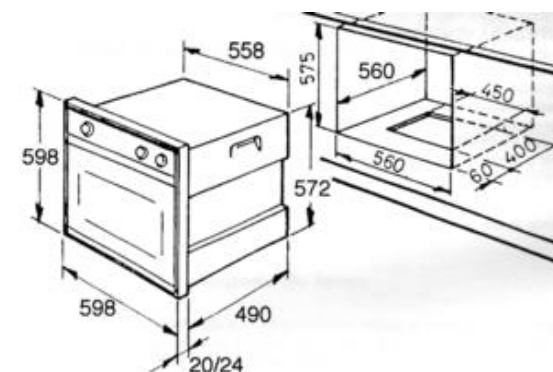



 inox

FEA2703 - Four multifonction



5 modes de cuisson

Minuterie

Cavité (53 litres brut) : L455 x P360 x H325 mm

Alimentation 220-240V (1,9kW max.)

kit catalyse disponible en option

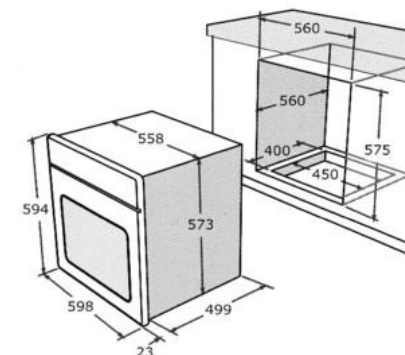

 ivoire

FEA47R1A - Four multifonction



7 modes de cuisson

Programmateur digital

Cavité (53 litres brut) : L455 x P360 x H325 mm

Alimentation 220-240V (2,2kW max.)

kit catalyse disponible en option

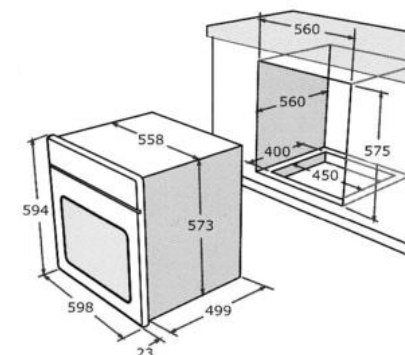

 inox

FEA65D53 - Four multifonction



6 modes de cuisson + 4 programmes spéciaux*

* (toast, poulet, pizza, chauffe-plats)

Programmateur digital

Cavité (53 litres brut) : L455 x P360 x H325 mm

Les + : **commandes sensibles**, thermostat électronique

Alimentation 220-240V (2,2kW max.)

kit catalyse disponible en option

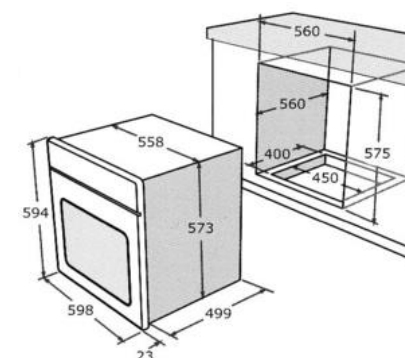



 inox

FEAL991 - Four multifonction



7 modes de cuisson
 Programmeur digital
 Cavité (53 litres brut) : L455 x P360 x H325 mm
 Les + : **ouverture latérale, commandes escamotables**
 Alimentation 220-240V (2,2kW max.)

kit catalyse disponible en option

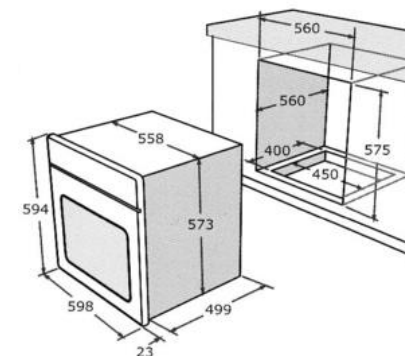

 verre **HOT**
ICE

FE461HI - Four multifonction



7 modes de cuisson
 Programmeur digital
 Cavité (53 litres brut) : L455 x P360 x H325 mm
 Les + : **finition verre design « bleu glacier »**
 Alimentation 220-240V (2,4kW max.)

kit catalyse disponible en option

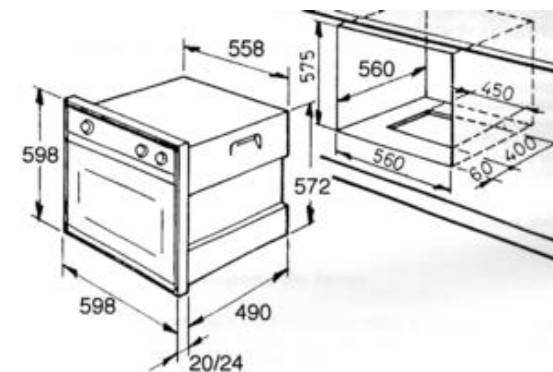



-  verre **noir**
-  **inox**

S5-E600MF - Four multifonction



9 modes de cuisson
 Programmateur digital à touches sensibles
 Cavité (63 litres brut): L465 x P400 x H340 mm
 Fonction **nettoyage vapeur**
 Les + : **Maxigrill**, Fonction spéciale **mijotage**
 Alimentation 220-240V (2,7kW max.)

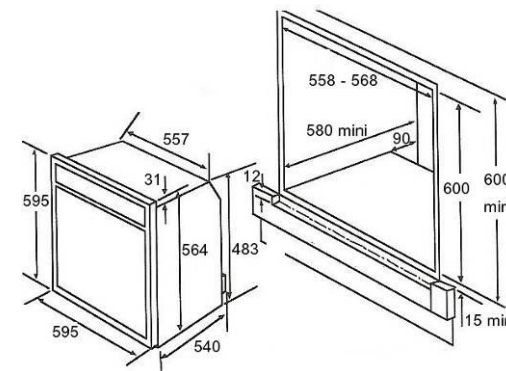





-  verre **noir**

GENUS 600 - Four multifonction ultra rapide

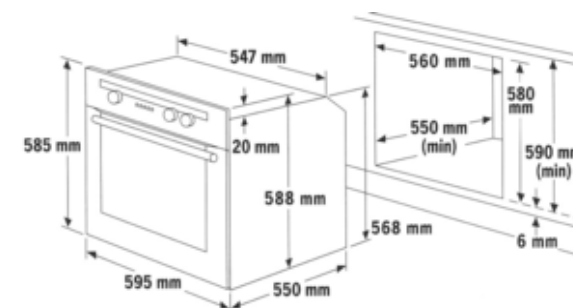

6 modes de cuisson + 8 programmes *Genus*
 Programmateur digital
 Cavité **hydroformée** (61 litres brut) : L470 x P370 x H350 mm
 Email haute densité **Pristine®**
 Les + : **Maxigrill**, modes **Genus**, thermostat électronique
 Alimentation 220-240V (7,4kW max.)



-  verre **blanc**
-  verre **crème**
-  verre **noir**

600EMa - Four multifonction



9 modes de cuisson
 Programmateur digital
 Cavité **hydroformée** (65 litres brut) : L470 x P400 x H350 mm
 Parois, angles et voûte auto dégraissants par catalyse
 Les + : **Maxigrill Vitro**, **Powercool**, **Slide&Clean**
 Alimentation 220-240V (2,7kW max.)

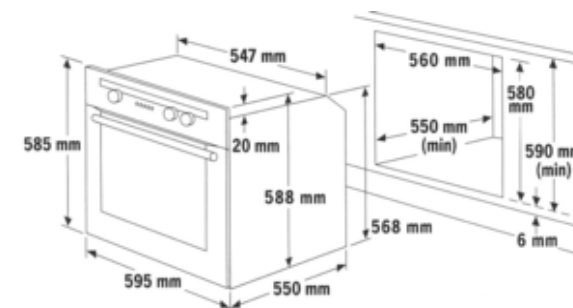



 inox

EL626 - Four multifonction



9 modes de cuisson
 Programmateur digital
 Cavité **hydroformée** (65 litres brut) : L470 x P400 x H350 mm
 Parois, angles et voûte auto dégraissants par catalyse
 Les + : **Slide&Clean**
 Alimentation 220-240V (2,4kW max.)

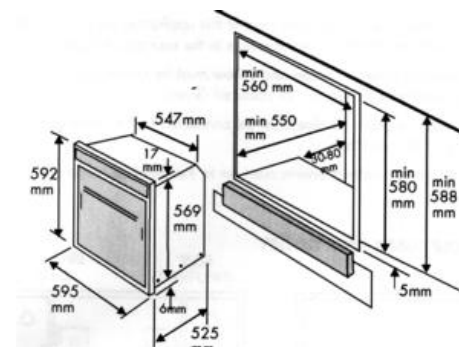

 verre noir

600EM - Four multifonction



9 modes de cuisson
 Programmateur digital
 Cavité **hydroformée** (65 litres brut) : L470 x P400 x H350 mm
 Parois, angles et voûte auto dégraissants par catalyse
 Les + : **Maxigrill, Powercool, Slide&Clean**
 Alimentation 220-240V (2,8kW max.)

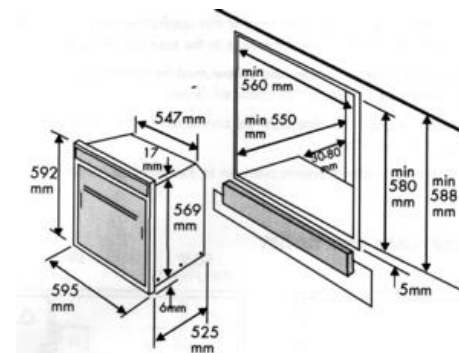



 inox

MO600SS - Four multifonction



7 modes de cuisson
 Programmeur simplifié à 2 commandes
 Cavité (71 litres brut): L465 x P420 x H365 mm
 Parois et voûte auto dégraissantes par catalyse
 Les + : **châssis « pro »** robuste, **Slide&Clean**
 Alimentation 220-240V (3,3kW max.)

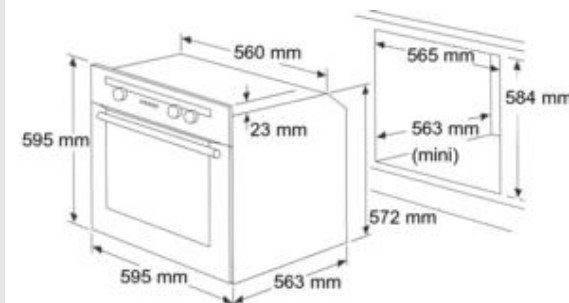

 inox

MG600SS - Gril indépendant



Cavité (31 litres brut): L465 x P420 x H160 mm
 Voûte auto dégraissante par catalyse
 Les + : **châssis « pro »** robuste, rails télescopiques
 Alimentation 220-240V (3,2kW max.)



 inox

MO600SS + MG600SS - Combiné Four + Gril

Combinaison du four MO600SS et du gril GR600SS grâce au **kit de jonction**



 inox

S7-E700MF - Four double multifonction



Four haut conventionnel : 3 modes de cuisson
Cavité (35 litres brut) : L465 x P425 x H175 mm



Four bas multifonction : 9 modes de cuisson / programmateur
Cavité (42 litres brut) : L465 x P385 x H235 mm

Fonction **nettoyage vapeur**

Les + : **Maxigrill**, thermostats électroniques, sonde à viande
Alimentation 230V (5,6kW max.)

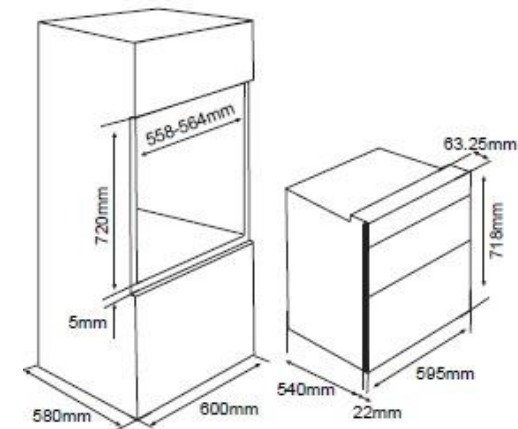



 inox

FEAD0784 - Four double multifonction



Four haut conventionnel : 4 modes de cuisson
Cavité (34 litres brut) : L455 x P370 x H200 mm



Four bas multifonction : 7 modes de cuisson
Programmateur digital
Cavité (53 litres brut) : L455 x P360 x H325 mm
kit catalyse disponible en option

Les + : **Slide&Clean**
Alimentation 220-240V (4kW max.)

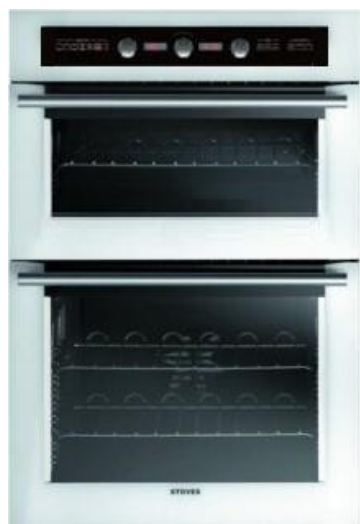
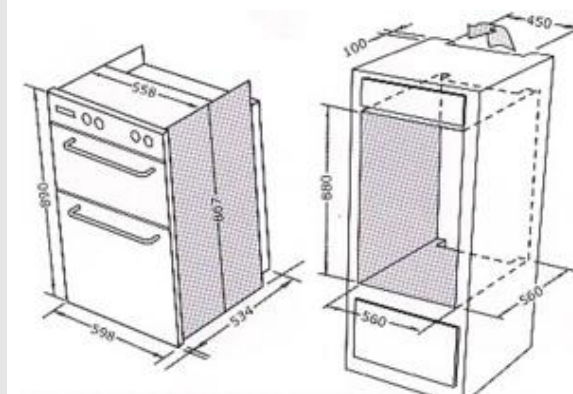

 verre blanc

907MF - Four double multifonction



Four haut ventilé : 2 modes de cuisson
Cavité **hydroformée** (39 lit. brut) : L470 x P420 x H200 mm



Four bas multifonction : 7 modes de cuisson
Programmateur digital
Cavité **hydroformée** (65 lit. brut) : L470 x P400 x H350 mm

Email haute densité **Pristine®**
Les + : **Maxigrill, Powercool, Slide&Clean**, th. électronique
Alimentation 220-240V (5kW max.)

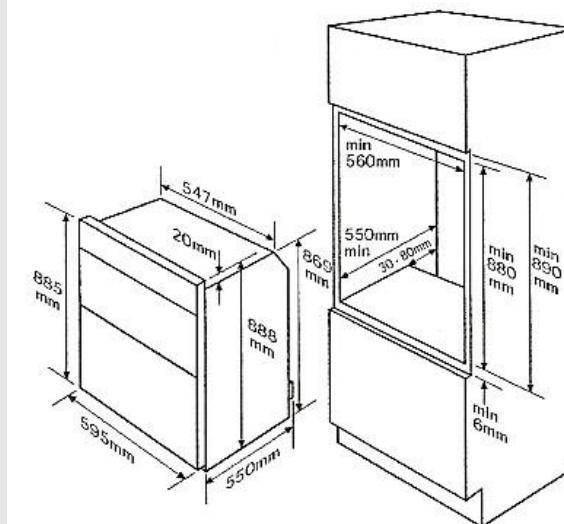



 inox

900DCa - Four double mixte (gaz+électricité)



Four du haut électrique : 2 modes de cuisson
Cavité **hydroformée** (37 litres brut) : L470 x P400 x H200 mm
Voûte auto dégraissante par catalyse



Four du bas à **gaz** (chauffe directe) / Programmateur
Cavité **hydroformée** (69 litres brut) : L470 x P420 x H350 mm
Parois, angles et voûte auto dégraissants par catalyse

Les + : **Maxigrill Vitro, Powercool, Slide&Clean**
Alimentation 220-240V (2,4kW max.)

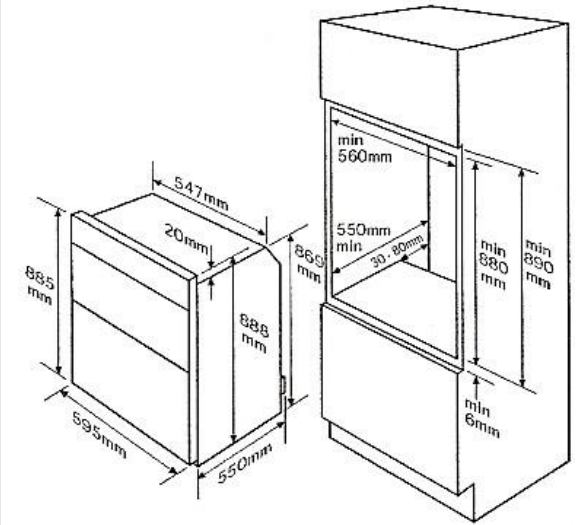



 inox

MILLENIUM - Four multifonction



5 modes de cuisson / Programmateur

Cavité **hydroformée** (82 litres brut): L620 x P380 x H350 mm

Parois, angles et voûte auto dégraissants par catalyse

Les + : **Maxigrill, Powercool, Slide&Clean**

Alimentation 220-240V (3,2kW max.)

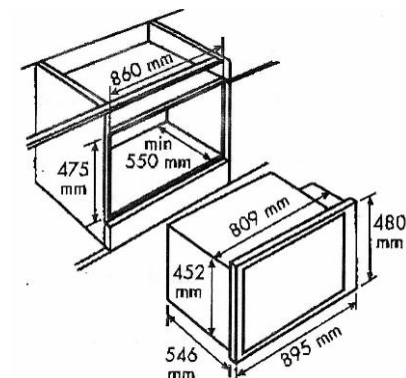

pour tout renseignement, contacter :

F & U
Fourneaux & Ustensiles

6A rue Jean Mermoz - 33185 Le Haillan
Tél. : +33 (0)5 56 34 29 41 – Fax : +33 (0)5 56 34 29 60
www.fourneaux.fr

F&U a une politique de développement constant. Cette brochure est précise au moment de son édition. Les couleurs et dimensions sont données à titre indicatif et peuvent légèrement varier de l'illustration. Dans un souci permanent d'amélioration, F&U et les producteurs se réservent le droit de modifier les caractéristiques des hottes et groupes d'aspiration sans préavis. Les produits présentés sont distribués par F&U - Fourneaux & Ustensiles, 6A rue Jean Mermoz, 33185 Le Haillan.