

## TG3600

### Traveling Geo

The TG Series of Geo and Cover fabricating machines are designed to eliminate excessive fabric handling. The TG series will efficiently produce almost any size Geo Liner or Cover.

By using our exclusively designed welding and pulling system, the TG3600 will dramatically reduce labor and increase production. Because we use your floor as our welding surface, the TG3600 only takes up limited floor space.

No pre-pulling, no folding, no excessive handling....The model TG3600.

- Throat capacity available in 3.65M (12ft)
- Cradled unwind stand
- Material fabric clamp
- Adjustable operator control platform
- Track assembly for up to 76.2M (250ft) of travel included
- Hot air heat system
- Multi color fabric requires 2 unwinds

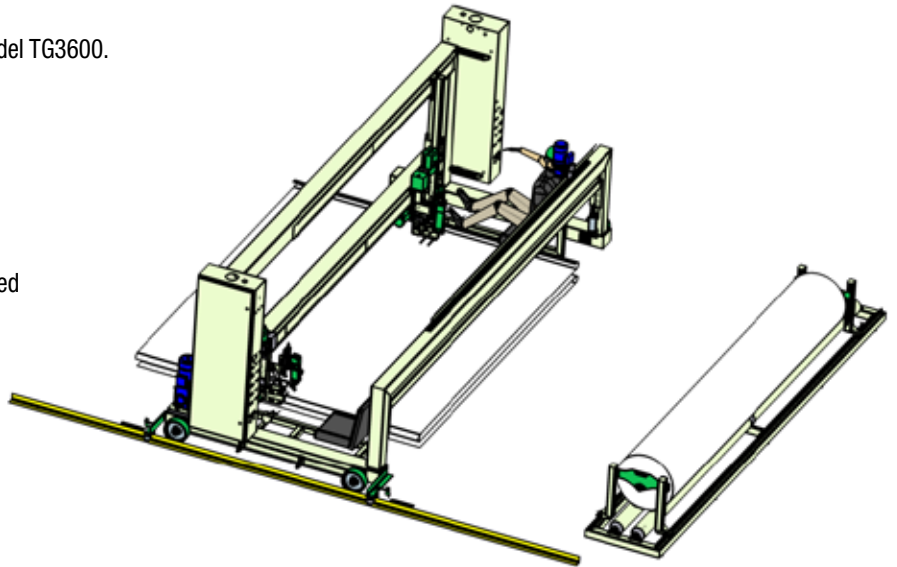

*TG3600 Series Seam Capabilities*

## Technical Specifications

Type	TG3600
Voltage	60 Amperes - Three Phases - 220volts *Transformer required for 400volts
Air Requirement	No Air / Onboard Air compressor
Throat Capacity	3.65M (12ft)
Standard Seam Weld Width	12mm – 50mm (.5in – 2in)
Welding Speed	Up to 12.2 M/min (40ft/min)*
Material you can weld	Woven Polypropylene, Woven Polyethylene, PVC laminated fabrics, PVC coated fabrics, Polyurethane coated fabrics, Polypropylene fabrics, and others

*\*Depending on the application, the seam width and the type of material used.*