

MPC TYPE "ST"

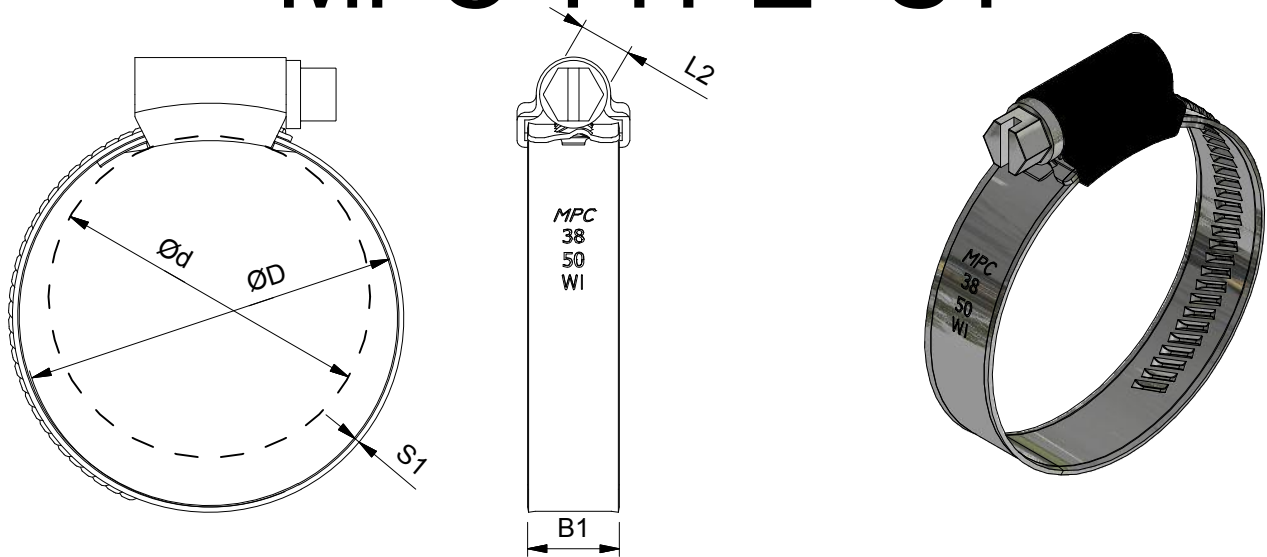

TABLE

clamp size minimum:	clamp size maximum:	Band width:	Band Thickness S1	Hexagon head Screw	Tightening Torque:	Breaking Torque:
d	D	B1	W2 W4 W5	L2	AD* in Nm	PD**
8	14	9	0,5 till 1	7	3Nm	4Nm
11	17	9	0,5 till 1	7	3Nm	4Nm
13	20	9	0,5 till 1	7	3Nm	4Nm
15	25	12	0,5 till 1	7	5Nm	6,5Nm
19	29	12	0,5 till 1	7	5Nm	6,5Nm
22	32	12	0,5 till 1	7	5Nm	6,5Nm
26	38	12	0,5 till 1	7	5Nm	6,5Nm
32	44	12	0,5 till 1	7	5Nm	6,5Nm
38	50	12	0,5 till 1	7	5Nm	6,5Nm
44	56	12	0,5 till 1	7	5Nm	6,5Nm
50	65	12	0,5 till 1	7	5Nm	6,5Nm
58	75	12	0,5 till 1	7	5Nm	6,5Nm
68	85	12	0,5 till 1	7	5Nm	6,5Nm
77	95	12	0,5 till 1	7	5Nm	6,5Nm
87	112	12	0,5 till 1	7	5Nm	6,5Nm
104	138	12	0,5 till 1	7	5Nm	6,5Nm
130	165	12	0,5 till 1	7	5Nm	6,5Nm
155	180	12	0,5 till 1	7	5Nm	6,5Nm
175	205	12	0,5 till 1	7	5Nm	6,5Nm
200	231	12	0,5 till 1	7	5Nm	6,5Nm
226	256	12	0,5 till 1	7	5Nm	6,5Nm
251	282	12	0,5 till 1	7	5Nm	6,5Nm
277	307	12	0,5 till 1	7	5Nm	6,5Nm
302	325	12	0,5 till 1	7	5Nm	6,5Nm
321	350	12	0,5 till 1	7	5Nm	6,5Nm
346	375	12	0,5 till 1	7	5Nm	6,5Nm
371	400	12	0,5 till 1	7	5Nm	6,5Nm
396	425	12	0,5 till 1	7	5Nm	6,5Nm
421	450	12	0,5 till 1	7	5Nm	6,5Nm

AD*= Maximum advised torque.

PD**=Minimum test torque in Nm according to DIN 3017-1.

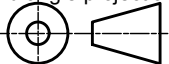
	Material:	W1, W4, W5	Part number:	ST clamp	
	Third angle projection:		Description:	MPC Industries, ST clamp, According to SMS 2298	
Drawn by: Gyula	Creation date: 28-1-2014	Units: mm	Revision:		
Scale 1:1			Format:	A4	