

The Packo EHEDG certified process pumps of the FP3 series are used in the most demanding hygienic applications in almost all industries such as dairies, breweries, beverage industry, distilleries, etc. These perfectly cleanable pumps have stainless steel 316L pump casings constructed in thick cold rolled plate, 100% non porous and extremely smooth. The pumps have closed impellers with 3-dimensionally profiled blades and large passage and they are constructed in 316L or duplex materials. Thanks to its crevice-free design and electropolishing as a final surface treatment, the FP3 pump series are perfectly cleanable, resulting in a reliable component into your production process.



Application areas

These perfectly cleanable process pumps are the ideal solution for filtration applications, pasteurisation, evaporating systems, yeast propagation and for CIP cleaning systems as well. Typical applications include filtration of beer, wine and fruit juices as well as pumping yeast, whey and curd.

Your benefits

- High pump efficiency resulting in lower energy consumption
- Low NPSH values: less risk on cavitation
- Electropolished: perfectly cleanable
- Easy construction and easy maintenance: Less downtime
- Standard components
- Easy to install
- 2 mechanical seal diameters for the entire range
- Robust construction

Technical specifications

Max. flow rate	320 m ³ /h
Max. differential head	120 m
Max. liquid viscosity	500 cP
Max. temperature	140°C
Impeller type	Closed with back vanes and balancing holes
Max. free passage	21 mm
Max. motor power	90 kW
Max. speed	3000 / 3600 rpm
Available frequency	50 / 60 Hz
Connections	Sanitary fittings
Materials wetted parts	Stainless steel 316L or similar
Available materials o-ring	EPDM, FKM, FEP-FKM, FFKM, Silicone
Mechanical seal configuration	Single, quench, double
Surface finish	Food quality, internal welds hand polished + electropolished (Casing 0.8 µm - Impeller 3.2 µm)
Certificates & Legislation	EHEDG, 1935/2004 EC, FDA, USP, ATEX, EU N° 547/2012



Performance curves at 2900 rpm

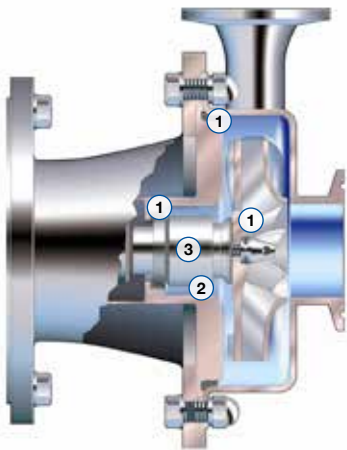
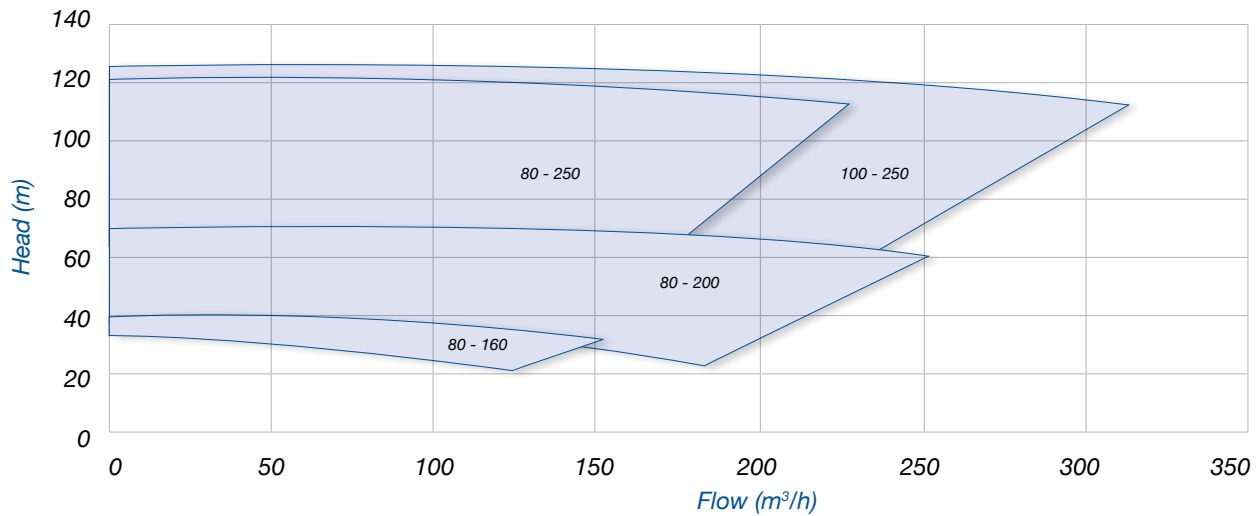

Specifications

- No bacteria traps and no small clearances in order to clean the area around the O-ring (1)
- Pressed stainless steel in 2B quality plate, extremely smooth
- Large seal cavity to clean mechanical seal properly (2)
- Standardized mechanical seals to EN 12756
- FDA approved bellow mechanical seals or sterile O-ring seals (spring not in contact with the liquid) (3)
- 1 mechanical seal diameter 43 mm up to 45 kW motor power (70 mm for motor power > 45 kW)
- Electropolished design for wetted & non-wetted parts: easy to clean and increased corrosion resistance

FP3_Sanitary_pump_series_Technosheet_rev01_2016_(eu)



Electropolished

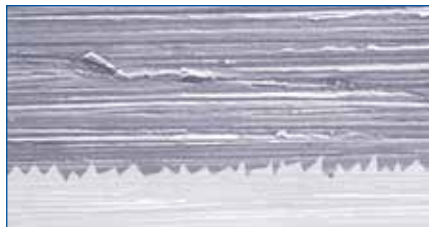

Mechanical polishing 240 grit



Glass bead blasted



Find your local supplier at www.verder-liquids.com

For construction, installation and floor mounting drawings please contact your local authorised Verder® distributor.

VERDER
passion for pumps