

901

VANNE PAPILLON TYPE "WAFER" WAFER BUTTERFLY VALVES

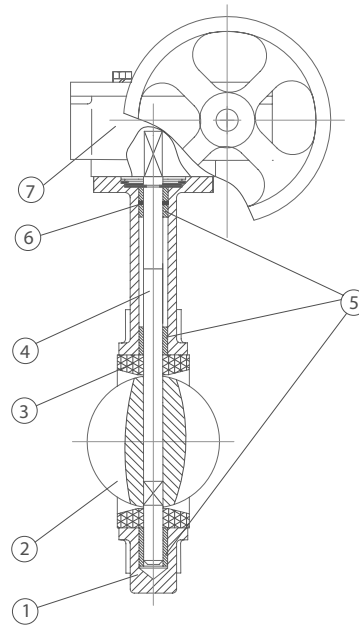

CE



DESCRIPTION DES COMPOSANTS - COMPONENTS DESCRIPTION

Index - Ítem	Description - Descripción	Matière - Material
1	Corps - Body	Fonte Grise - Grey Cast Iron GG 25 (EN-GJL-250)
2	Disque - Disc	Acier Inoxydable - Stainless Steel AISI 316 (CF8M)
3	Siège - Seat	EPDM
4	Axe - Stem	Acier Inoxydable - Stainless Steel AISI 416
5	Paliers - Bushing	PTFE
6	Joints Toriques - O-Ring	EPDM
7	Volant réducteur - Gear Operator	Fonte Grise - Grey Cast Iron GG 25 (EN-GJL-250)

CARACTERISTIQUES

- Pression de travail PN 16.
- Température de service: de -10 °C à +120 °C.
- Montage avec Brides PN 10/16.
- Revêtement extérieur "EPOXY", 250 µm.
- Embase ISO 5211 pour le montage d'actionneur.
- Vanne de régulation.
- Axe en une seule pièce.
- Pas de crochet pour raccorder le disque et l'axe (excepté les DN350, DN400 et DN500).
- Ne nécessite pas de joint pour un montage entre Brides.
- Col allongé pour une meilleure isolation thermique.
- Design bidirectionnel.

DOMAINES D'APPLICATION

- Systèmes hydrauliques.
- Adduction d'eau et pompage.
- Applications industrielles basse pression et basse température.
- Installations d'irrigation.
- Ouvrages hydrauliques civiles.
- Climatisation.

BASIC FEATURES

- Working pressure PN 16.
- Working temperature: -10 °C to 120 °C.
- Suitable for flanges PN 10 / PN 16.
- Outside "EPOXY" powder coating, 250 µm.
- Top flange ISO 5211 for actuator.
- Control valve.
- One piece stem.
- Not pins to joint disc and stem (except DN350, DN400 and DN500).
- No need gaskets between valve and counter flanges.
- Long neck to facilitate thermal isolation.
- Bidirectional design.

GENERAL APPLICATIONS

- Water systems.
- Water supply, pumping and connection plants.
- Low pressure and low temperature industrial applications.
- Irrigation systems.
- Hydraulic and civil works.
- HVAC systems.

Rev.0-03.19
1/2



Polígono Industrial ATUSA - Agurain S/N - 01200 Salvatierra (Alava) España
Tel.: (+34) 945 18 00 00 Fax : (+34) 945 30 01 53 e-mail: ventas@atusa.es
www.atusa.es



901

VANNE PAPILLON TYPE "WAFER" WAFER BUTTERFLY VALVES

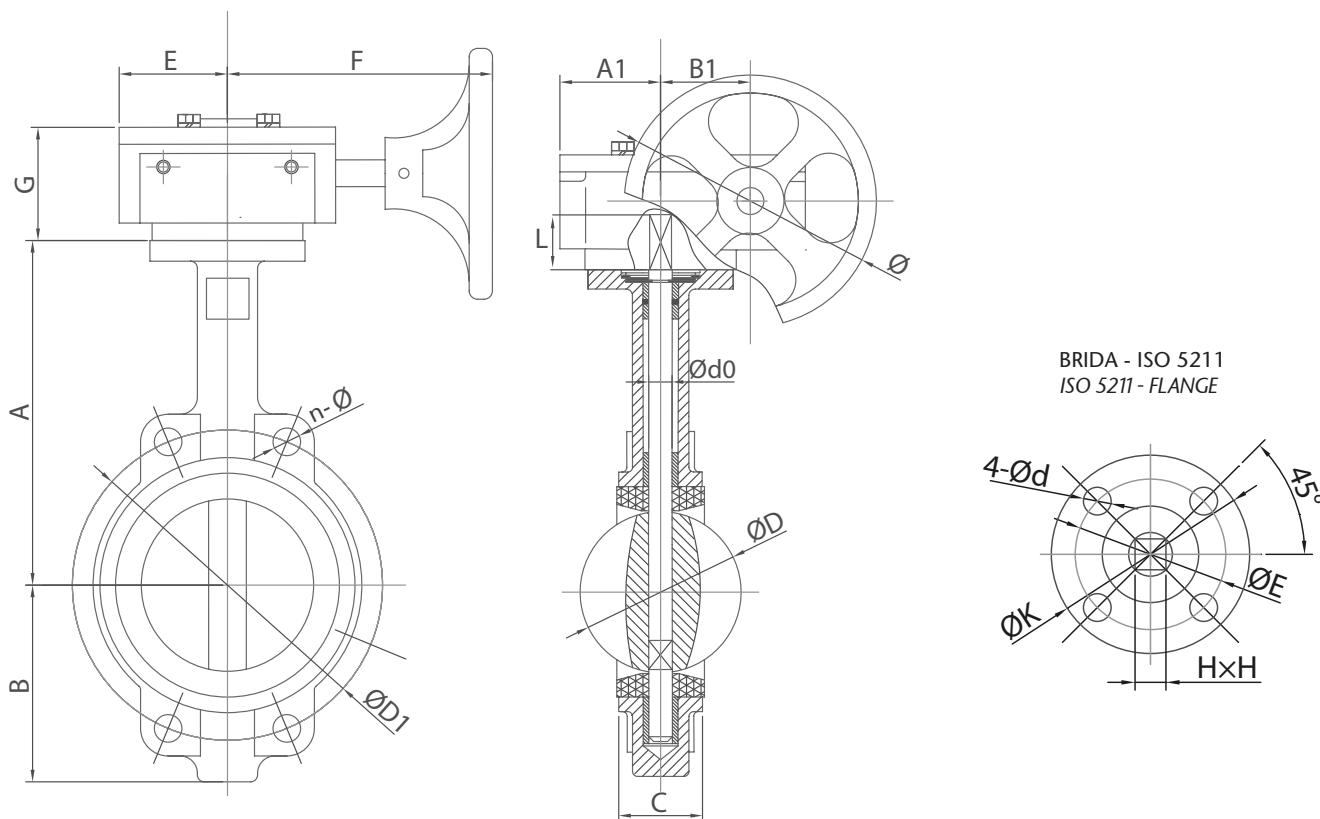

INFORMATION TECHNIQUE - TECHNICAL INFORMATION

DN	CODE	DIMENSIONS - DIMENSIONS (mm)																		Poids approx. Weight approx. (kg)	
		A	B	C	Ød0	ØD	ØD1	n - Ø	L	H x H	BRIDE/FLANGE - ISO 5211			VOLANT REDUCTEUR/ GEAR OPERATOR							
											4 - Ød	K	E	G	E	F	A1	B1	Ø		
40	VF901040	150	65	33	12,6	42,8	110	4 - 19	24	9x9	F05	4 - 7	70	50	61	52	153	52	45	146	5,1
50	VF901050	161	75	42	12,6	52,9	125	4 - 19	29	9x9	F05	4 - 7	70	50	61	52	153	52	45	146	5,8
65	VF901065	175	89	45	12,6	64,5	145	4 - 19	29	9x9	F05	4 - 7	70	50	61	52	153	52	45	146	6,2
80	VF901080	181	95	46	12,6	78,8	160	8 - 19	26	11x11	F05	4 - 7	70	50	61	52	153	52	45	146	6,5
100	VF901100	200	114	52	15,8	104,0	180	4 - 19	26	11x11	F05	4 - 7	70	50	61	52	153	52	45	146	7,7
125	VF901125	213	127	55	18,9	123,3	210	4 - 19	28	14x14	F07	4 - 9	90	70	61	52	153	52	45	146	10,2
150	VF901150	226	139	56	18,9	155,1	240	4 - 23	32	14x14	F07	4 - 9	90	70	61	52	153	52	45	146	10,8
200	VF901200	260	175	61	22,1	202,5	295	4 - 23	29	17x17	F07	4 - 9	90	70	73	75	250	75	63	266	18,1
250	VF901250	292	203	66	28,5	250,5	355	4 - 28	38	22x22	F10	4 - 12	125	102	73	75	250	75	63	266	25,0
300	VF901300	337	242	77	31,6	301,6	410	4 - 28	34	22x22	F10	4 - 12	125	102	73	81	227	81	80	266	37,0
350	VF901350	368	267	77	31,6	333,3	470	4 - 26	45	22x22	F10	4 - 12	140	102	73	81	227	81	80	300	49,0
400	VF901400	400	309	87	33,15	389,6	525	4 - 30	52	27x27	F14	4 - 18	197	140	98	127	250	127	120	300	77,0
500	VF901500	480	361	127	41,15	491,6	650	20 - 28	65	36x36	F14	4 - 18	197	140	120	127	250	127	120	300	139,0

Note : En raison de l'évolution constante de nos produits, ces spécifications peuvent être modifiées sans préavis.

Note : Due to the continuous development of our products, specifications may be changed without notification at any time.

Rev.0-03.19
2/2



Polígono Industrial ATUSA - Agurain S/N - 01200 Salvatierra (Alava) España
Tel.: (+34) 945 18 00 00 Fax : (+34) 945 30 01 53 e-mail: ventas@atusa.es
www.atusa.es

