

Table de nomenclature

REP.	DESIGNATION (FR)	DESIGNATION (ENGLISH)	QTE
1	STRUCTURE	STRUCTURE	1
2	MANCHETTE FILTRANTE	FILTER	1
3	FOURCHE AVEC ENTRAXE REGLABLE	FORK WITH ADJUSTABLE WIDTH	2
4	TUBE DE REMPLISSAGE	FILLING TUBE	1
5	ANNEAU MULTI-DIAMETRE	MULTI-DIAMETER RING	1
6	JOINT GONFLANT	INFLATING SEAL	1
7	SUPPORT DE FOURCHES	FORKS SUPPORT	1
8	VERIN PNEUMATIQUE	PNEUMATIC CYLINDER	1
9	COFFRET PNEUMATIQUE	PNEUMATIC BOX	1

DIMENSION : [inch] / mm PLAN D'INFORMATION / INFORMATION DRAWING

PALAMATIC N'AYANT PAS EN CHARGE LE GENIE CIVIL, IL EST DE VOTRE RESPONSABILITE DE VOUS ASSURER DE LA RESISTANCE, DE LA STABILITE ET DE LA PLANEITE DE VOS SUPPORT OU SOLS RECEVANTS NOS EQUIPEMENTS, AUX DIFFERENTS EFFORTS ET CONTRAINTES AUQUELS ILS POURAIENT ETRE SOUMIS.

CE PLAN EST LA PROPRIETE DE LA SOCIETE PALAMATIC - IL NE PEUT ETRE COPIE OU UTILISE SANS AUTORISATION
THIS DRAWING IS THE PROPERTY OF THE COMPANY PALAMATIC - IT CANNOT BE COPIED OR USED WITHOUT AUTHORIZATION

CIVIL ENGINEERING WORKS ARE NOT INCLUDED IN PALAMATIC'S SCOPE OF SUPPLY. IT IS THE CLIENT'S RESPONSIBILITY TO ENSURE THE STABILITY, RESISTANCE AND FLATNESS OF THE STRUCTURES AND TERRAIN ON WHICH, PALAMATIC'S EQUIPMENT WILL BE MOUNTED. THESE STRUCTURES AND TERRAIN MUST BE ABLE TO WITHSTAND THE DIFFERENT LOADS AND CONSTRAINTS BROUGHT ON BY THESE EQUIPMENTS

Rue de l'Écolais 02 90 56 20 61
 Z.A. de la Croix Rouge
 35530 BRECE
 CYRIL.PICHARD@PALAMATIC.FR



28-03-19		A	DIFFUSION	CYP	Format / Echelle / Scale		N° Plan / Drawing number		REV: A 1/2
DATE	REV	OBSERVATION	REVISER / REVISER	REVISER / REVISER	A3	1:20			

Designation / Name : **REMPLISSAGE BIG BAG** Dessiné par / Drawn by : **PICHARD**
 Description : **FLOWMATIC 02** Ref. Dossier / Project reference :

REPLISSAGE BIG BAG / BIG BAG FILLING:

DECHARGEMENTE BIG BAG / BIG BAG UNLAODING:

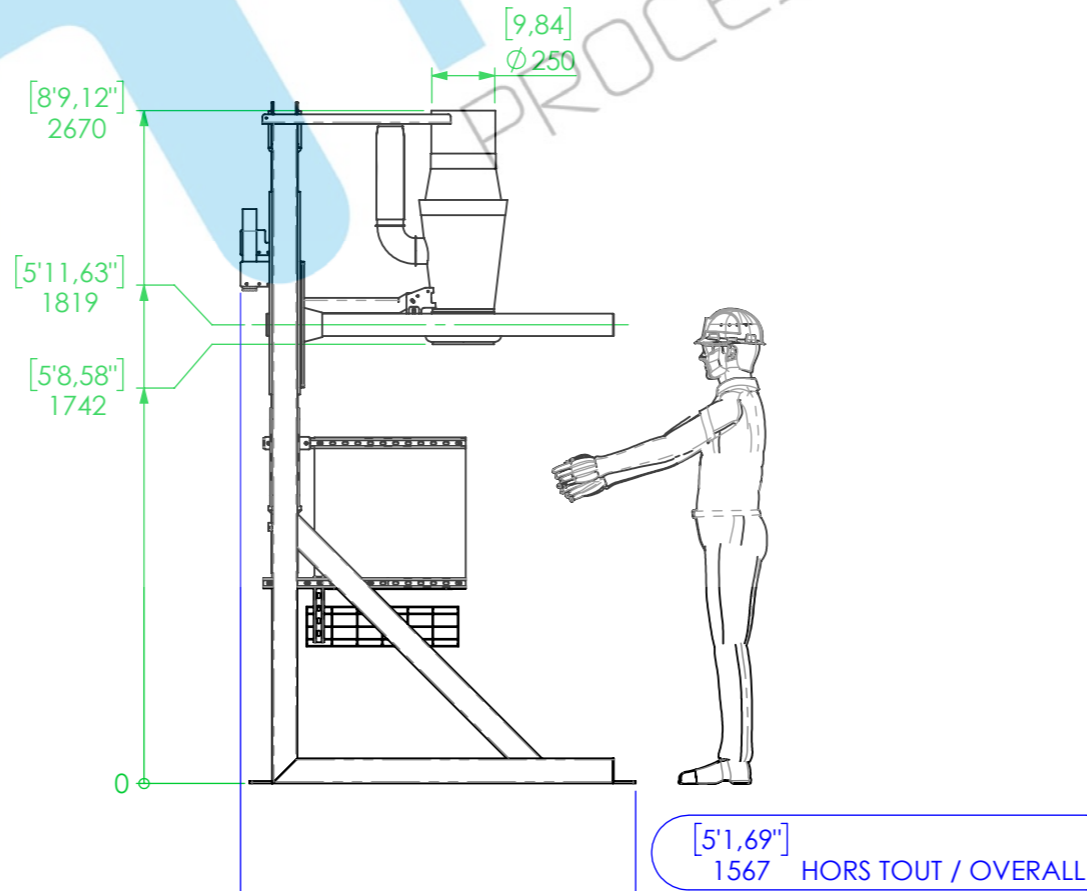
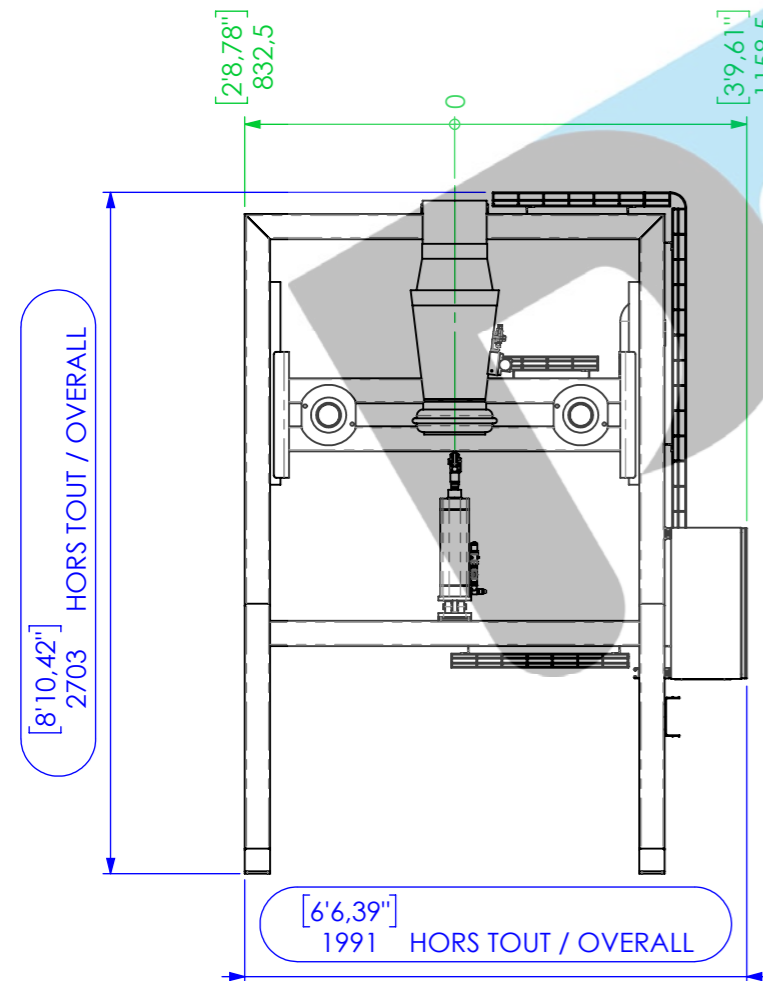
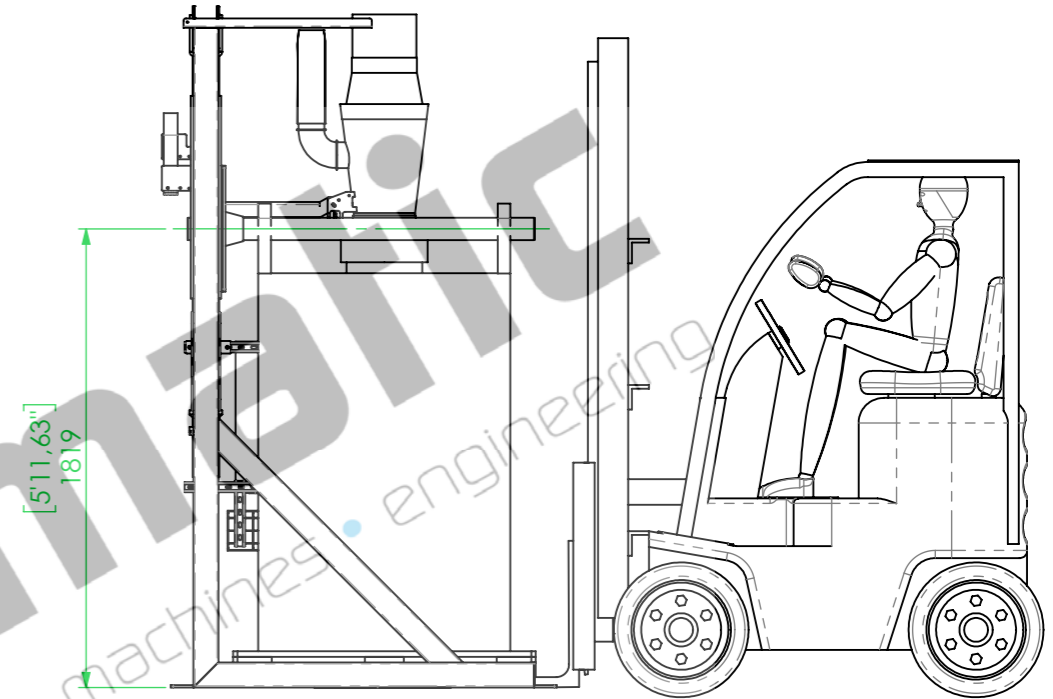
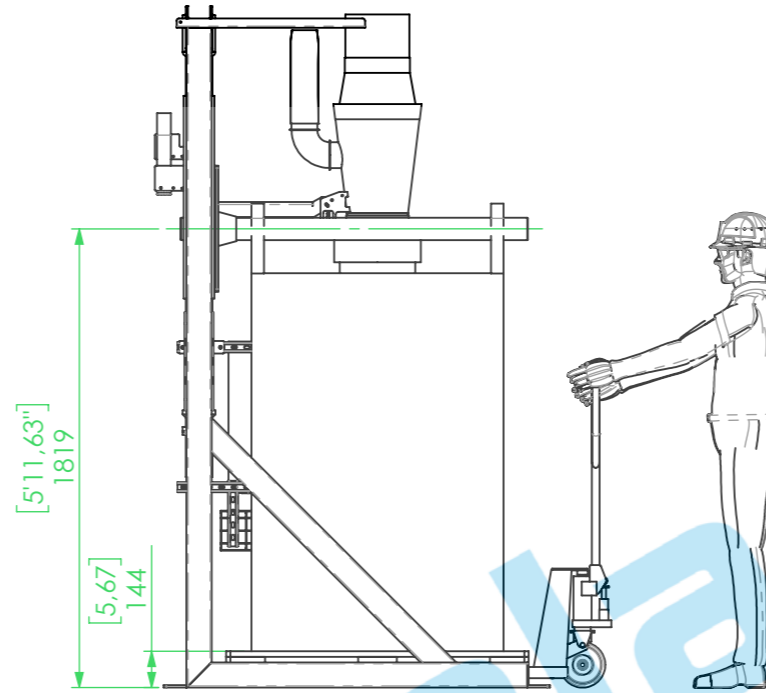
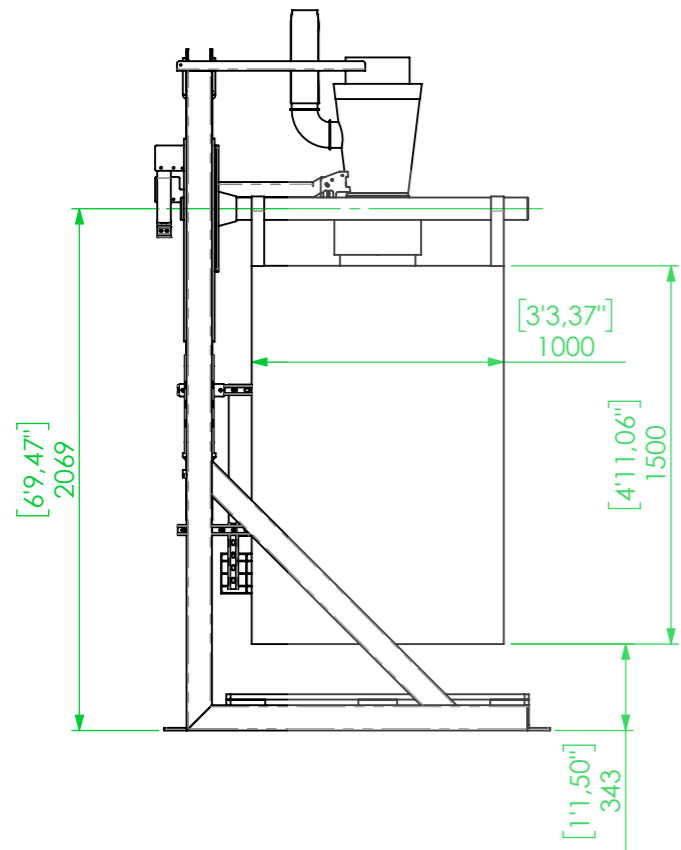

DIMENSION : [inch] / mm PLAN D'INFORMATION / INFORMATION DRAWING

PALAMATIC N'AYANT PAS EN CHARGE LE GENIE CIVIL, IL EST DE VOTRE RESPONSABILITE DE VOUS ASSURER DE LA RESISTANCE, DE LA STABILITE ET DE LA PLANEITE DE VOS SUPPORT OU SOLS RECEVANTS NOS EQUIPEMENTS, AUX DIFFERENTS EFFORTS ET CONTRAINTES AUQUELS ILS POURAIENT ETRE SOUMIS.

CIVIL ENGINEERING WORKS ARE NOT INCLUDED IN PALAMATIC'S SCOPE OF SUPPLY. IT IS THE CLIENT'S RESPONSIBILITY TO ENSURE THE STABILITY, RESISTANCE AND FLATNESS OF THE STRUCTURES AND TERRAIN ON WHICH, PALAMATIC'S EQUIPMENT WILL BE MOUNTED. THESE STRUCTURES AND TERRAIN MUST BE ABLE TO WITHSTAND THE DIFFERENT LOADS AND CONSTRAINTS BROUGHT ON BY THESE EQUIPMENTS

CE PLAN EST LA PROPRIETE DE LA SOCIETE PALAMATIC - IL NE PEUT ETRE COPIE OU UTILISE SANS AUTORISATION

THIS DRAWING IS THE PROPERTY OF THE COMPANY PALAMATIC - IT CANNOT BE COPIED OR USED WITHOUT AUTHORIZATION

Rue de l'Écolais 02 90 56 20 61
Z.A. de la Croix Rouge
35530 BRECE
CYRIL.PICHARD@PALAMATIC.FR



Designation / Name :		Description :	
REPLISSAGE BIG BAG		PICHARD	
Format :		Echelle / Scale :	
A3		1:30	
N° Plan / Drawing number :		REV: A 2	