



# OPERATION MANUAL

## COMPACT TRACTOR

504G3



[WWW.KNEGT-INTERNATIONAL.COM](http://WWW.KNEGT-INTERNATIONAL.COM)

# 504G3 SERIES TRACTOR

## OPERATION MANUAL

Please Read and Save This Manual

KNEGT QUALITY TRACTOR EUROPE

2018.09

### FOREWORD


These series model KNEGT 504G3 is a series newly developed product of Knekt Quality Tractors Europe and are powered with the four-cylinder diesel engines that have the features of ample output, less vibration and low noise as well.

Model 504G3 tractors are of single-function type for using in both paddy and dry fields. The designers have cogitated on some components, which can be selected for assembling in order to meet users' various needs.

In order to fit in with the international market, some components for perfecting the tractor have been designed and developed, such as the hydraulic power steering, hydraulic PTO clutch, two-speed PTO and so on. All of these have improved the performance of the tractor greatly.

These tractors have the advantages of economic fuel consumption, easy operation, harmonious appearance, compact construction and easy maintenance. This tractor series is only used for conventional agriculture and domestic purposes and similar operations, with the suitable agricultural machinery, for other operating contrary to the intended use of the tractor, such as **shall not be used for front-end loader and forestry application and spraying**. This tractor can only be operated by the personnel who is familiar with tractor's characteristics and have the knowledge of relevant safe manipulation, the same for maintenance and repair. This tractor can not be operated by children and agedness and other personnel who is not to conformity with the provisions.

**Read the Operation Manual carefully before starting, using, maintaining, refueling or making other service interventions on the tractor. Comply strictly with the safety regulation and follow the suggested precautions in order to safeguard yourselves. If you are unsure about anything, ask your East Wind dealer or employer. Do not guess, others and you could be killed or seriously injured.**

**Many warning sign alerts such as ‘’ on the tractor and operation manual. This warning sign alerts you about important messages involving your safety. Read these safety rules attentively and strictly follow suggested precautions to avoid any potential danger and ensure your health and personal safety.**

In order to meet users' needs continuously, this tractor is subject to improvement without notice. It may happen to the fact that there are some differences between the manual/illustrated parts catalogue and the structure of the real tractors. So the dealers or users are requested to provide PIN number and manufacturing date of the tractor while placing order for spare parts.

Thank you for purchasing the **KNEGT** Brand Tractor and cordially welcome your advice, suggestions and comments on our product so that we can make improvements timely in future.

Knegt Quality Tractor Europe

September 2018

## CONTENT

<b>Chapter 1 Safety Precautions.....</b>	<b>5</b>
1.1 Safety Instructions.....	5
1.2 Safety symbols .....	12
1.3 Measures for emergency .....	16
<b>Chapter 2 Technical Specifications.....</b>	<b>17</b>
2.1 Tractor characteristic .....	17
2.2 Identifying your machine .....	17
2.3 Technical specification of the tractor .....	19
<b>Chapter 3 Running-in of the tractor .....</b>	<b>27</b>
3.1 Preparation before Running-in of the tractor .....	27
3.2 Running-in the engine without load.....	27
3.3 Running in of hydraulic hitch system .....	28
3.4 Running-in of hydraulic steering system .....	28
3.5 Running in of PTO .....	28
3.6 Running in of the Tractor .....	29
3.7 Maintenance after running-in.....	30
<b>Chapter 4 Operating tractor.....</b>	<b>32</b>
4.1 Instrument and Controls.....	32
4.3 Using the Tractor implents .....	52
4.4 The use of electrical systems.....	60
<b>Chapter 5 Maintenance .....</b>	<b>63</b>
5.1 Oil and lubricants .....	63
5.2 Periodic Service .....	64
5.3 Transporting the Machine .....	66
5.4 Storage.....	68
<b>Chapter 6 Adjustment of the tractor.....</b>	<b>70</b>
6.1 Adjustment of the engine .....	70
6.2 Adjustment of the clutch .....	70
6.3 Adjustment of the Brake .....	71
6.4 Adjustment of the Chassis .....	72
6.5 Adjustment of the Front Axle (4WD).....	74

## 504G3 SERIES TRACTOR OPERATION MANUAL

---

6.6 Adjustment of the toe-in.....	78
6.7 Adjustment of the wheel track.....	78
6.8 Adjustment of rockshaft system.....	79
<b>Chapter 7 Troubleshooting.....</b>	<b>81</b>
7.1 Clutch.....	81
7.2 Gearbox.....	82
7.3 Rear axle.....	82
7.4 Braking system.....	83
7.5 Front driven axle (4WD).....	83
7.6 Walking system.....	84
7.7 Hydraulic steering system.....	84
7.8 PTO.....	85
7.9 Hydraulic Hitch System.....	86
7.10 Electrical system.....	87
7.11 Heating system.....	88
<b>Chapter 8 Appendix.....</b>	<b>89</b>
Appendix 1 Standards and Regulations.....	89
Appendix 2 Tightening Torque Table of Main Bolts and Nuts.....	90
Appendix 3 Scheme of the electric system.....	91
Appendix 4 List of damageable parts.....	92
Appendix 5 List of Attached Tools.....	92
Appendix 6 Mechanical couplings.....	93
Appendix 7 E-MARK certificate.....	99
Appendix 8 Optional Accessories.....	106
Appendix 9 Application Packing List.....	106

## Chapter 1 Safety Precautions

### 1.1 Safety Instructions

#### 1.1.1 Safety first

The respect of the rules for tractor use, maintenance and repair given in this manual is an essential element for the correct use of the tractors as envisioned by the manufacturer.

Carefully read all safety messages in this manual and on your machine safety signs. Replace missing or damaged safety signs. Be sure new equipment components and repair parts include the current safety signs. Replacement safety signs are available from your Knegt dealer.



Learn how to operate the machine and how to use controls properly. Do not let anyone operate without instruction.

Keep your machine in proper working condition. Unauthorized modifications to the machine may impair the function and safety and affect service life of machine.

Lightning and high voltage cable can kill you. Do not use the machine if there is lightning in your area or under high voltage cable.

Handle fuel carefully, it is highly flammable. Do not refuel the machine while smoking or when near open flame or sparks.

Always stop the engine before refueling machine. Fill fuel tank outdoors.

Prevent fires by keeping machine clean of accumulated trash, grease, debris. Always clean up spilled fuel.

Please remember that you will undertake the personal responsibility for any associated consequences with the improper use of these tractors. All the time you are working with or on the machine, take care and stay alert. Always be careful. Always be alert for hazards.

It is extremely dangerous to operate machinery when under the influence of alcohol or drugs. Do not drink excessively or take drugs before or while operating the machine or attachments. Be aware of medicines which can cause drowsiness.

## 504G3 SERIES TRACTOR OPERATION MANUAL

---

Do not attempt to operate the machine if you are feeling unwell. By doing so you could be a danger to yourself and those you work with.

You can reduce the risk of damage to the machine or your body by following the instructions in this manual.

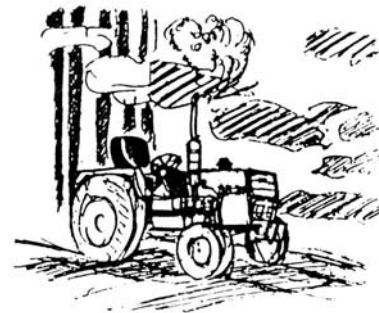
If you do not understand any parts of this manual and need assistance, contact your Knecht dealer.

This machine is manufactured in compliance with legislative and other requirements. It should not be altered in any way which could affect or invalidate any of these requirements. For advice consult your Knecht Distributor.

**Use only the Knecht approved attachments that are specified for your machine. Operating with nonspecified attachments can overload the machine, causing possible damage and machine instability which could result in injury to yourself or others. The use of non-approved attachments could invalidate your warranty.**

### 1.1.2 Start the tractor

1. Keep all guards and shields in the right place.
2. Make sure that everyone be away from the machine, attached implements, and work area before starting engine or operation.
3. Start engine only from seat with shuttle control in Neutral.
4. Front drive lever should be neutral and PTO switch must be disengaged before starting the engine.
5. Make sure all implements are fully lowered down to the ground before starting the engine.
6. Don't start engine by shorting across starter terminals. Otherwise it may cause injury or even death to you.



### 1.1.3 Operating the tractor safely

1. Select the track width setting best suited for work, always keeping tractor stability

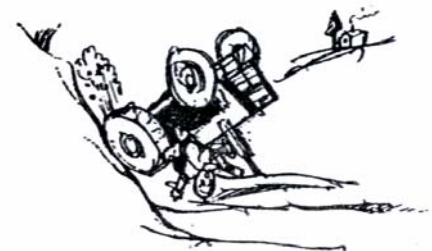
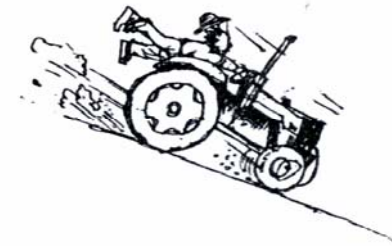


## 504G3 SERIES TRACTOR OPERATION MANUAL

---

in mind.

2. Engage clutch gradually. Abrupt engagements, particularly if pulling out of a low area, a ditch or muddy grounds, or driving over a steep gradient, may cause dangerous tractor pitching. Immediately disengage the clutch if the front wheels tend to come off the ground.
3. When coasting downhill, keep the transmission gear engaged. Never disengage the clutch and never drive your tractor in neutral.
4. When tractor is in motion, the operator should be correctly seated in the driver's seat.
5. Do not get on or off a moving tractor.
6. Keep all children and nonessential personnel off tractors and all equipment.
7. Always press the brake pedal gently.
8. Reduce speed when turning, applying individual brakes, or operating around hazard on rough ground or steep slopes.
9. Always operate the tractor at a safe speed for the type of ground being worked. When operating on rough ground, use proper caution to assure tractor stability.
10. When working on sloping grounds (i.e. hillsides) drive at moderate speed, particularly when steering.
11. Always try to go straight up or straight down a slope, never at an angle.
12. Proceed with extreme caution when driving with wheels close to the edge of a ditch or bank.
13. Never ride on a tractor unless seated on a



## 504G3 SERIES TRACTOR OPERATION MANUAL

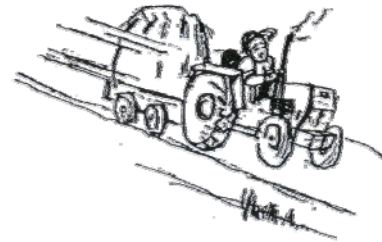
---

Knegt approved seat with seat belt.

14. When driving on public roads, be sure to respect traffic rules and regulations.
15. Do not rest your feet on the brake and the clutch pedals.
16. When driving on roads latch the brake pedals together by using the latch plate, braking with the pedals unlatched may cause side skidding of the tractor. Try to avoid overworking the brakes.

### 1.1.4 Towing loads

1. To assure tractor stability while working, correctly adjust the towing attachments (depending on the towed trailer or drawn implement).
2. Be careful when towing and stopping heavy loads. Stopping distance increase with speed and weight of towed loads, and on slopes. Towed loads with or without brakes that are too heavy for the tractors or are towed too fast can cause loss of control.
3. For your personal safety, trailers should not be towed unless equipped with an independent braking system.
4. Always use drawbar and towing equipment to pull heavy loads. Never hook or connect towed equipment to the 3-point hitch lower links or to the top link because pitching danger exists.
5. When towing never attempt to make a turn with a locked differential, because you may not be able to steer the tractor.



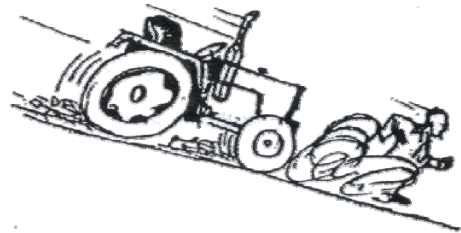
### 1.1.5 Using Agricultural Implements and Machines

1. Do not connect implements or machinery requiring a higher power rating than your tractor class.
2. Do not negotiate sharp turns with the PTO under heavy load; this will avoid damaging the universal joints of the PTO (power take-off) propeller shaft.
3. When connecting the implement to the tractor never stand between the two, while



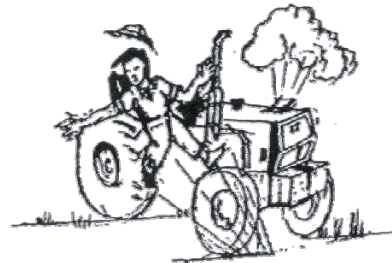
the tractor is being backed up.

4. Never activate the power take-off (PTO) when it is connected to a moving implement, without previously making sure that no one is within operating range of this implement.
5. You can be injured if you use faulty lifting equipment. Make sure that lifting equipment is in good condition. Make sure that lifting tackle complies with all local regulations and is suitable for the job. Make sure that lifting equipment is strong enough for the job. Raised equipment can fall and injure you. Do not walk or work under raised equipment unless safely supported.
6. No standing on the 3-point hitch or the shield. It may cause accident.



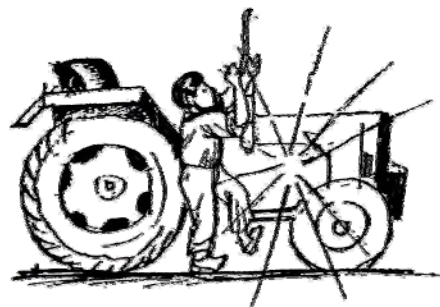
### 1.1.6 Parking and leaving the tractor

1. Before dismounting, disengage PTO, move transmission control lever to neutral, stop engine, lower implements or attachments to ground and securely engage the park brake. In addition, if the tractor is left unattended, remove key.
2. When parking look for level grounds if any, shift into gear and lock the park brake. On sloping grounds in addition to locking the park brake, shift into first forward gear if uphill or into first reverse gear if downhill. For greater safety also use the specific stopping wedge (available on request); be sure to do so if parking your tractor with a trailer.



### 1.1.7 Tractor Maintenance

1. Allow engine to cool off sufficiently before removing the radiator cap. With the engine shut-off, slowly turn the cap and release pressure before removing it completely.
2. Disconnect the storage battery ground cable before starting to work on any of the electrical system's

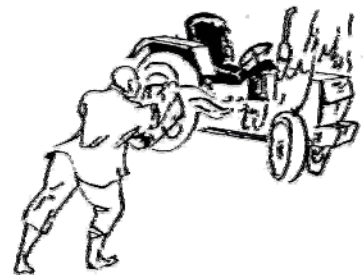


## 504G3 SERIES TRACTOR OPERATION MANUAL

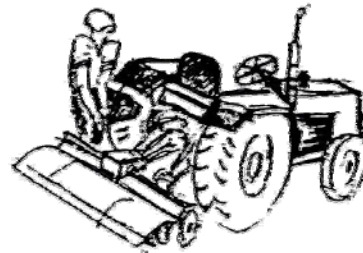
---

parts or components.

3. Before disconnecting any hydraulic line or hose, make sure the system is pressure-free.
4. Hydraulic oil escaping under pressure can cause serious personal injury. When searching for or detecting oil leaks, make sure to use adequate safety protection such as shields, goggles and gloves.
5. Prior to inspection, cleaning, adjustment or maintenance of the tractor or any mounted or connected implement, always make sure that engine is shut off. Also make sure the transmission is in neutral, the brakes are locked, the power take-off (PTO) is disengaged and all other moving parts are stationary.

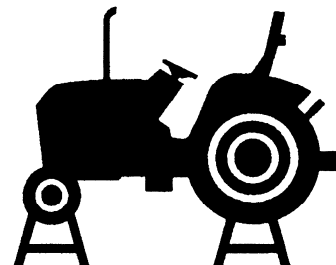


6. Do not fill fuel tank completely when expecting to work in full sunlight because the fuel might expand and escape. In such case, promptly wipe off any fuel that has escaped.



7. Tractor fuel may be dangerous. Never refuel while engine is running, is still hot, or you are near an open flame or when someone is smoking.

8. Do not service the tractor while it is in motion or while the engine is running. When servicing front-wheel-drive-equipped tractor with rear wheels supported off ground and rotating wheels by engine power, always support front wheels in a similar manner. Engaging front-wheel drive will pull rear wheels off support if front wheels are not raised. Tighten wheel hardware to correct torque as specified in Wheels, Tires and Tread section. Torque at intervals shown in Break-In Period and Lubrication and Maintenance sections, to ensure that wheel hardware does not loosen. Reinstall protective covers removed during service.



9. Do not work on tires unless suitable tools are available and you have the training

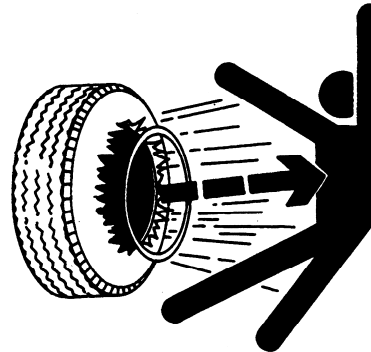
## 504G3 SERIES TRACTOR OPERATION MANUAL

---

and experience for tire repair. Any incorrect tire installation may seriously threaten your personal safety. If any doubt exists, have work done by qualified persons.

Explosive separation of a tire and rim parts can cause serious injury or death.

Always maintain the correct tire pressure. Do not inflate the tires above the recommended pressure. Never weld or heat a wheel and tire assembly. The heat can cause an increase in air pressure resulting in a tire explosion.

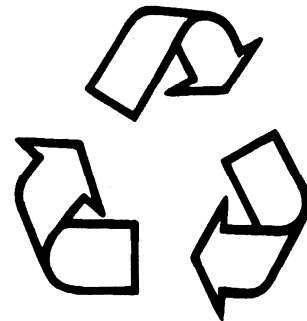


Welding can structurally weaken or deform the wheel.

When inflating tires, use a clip—on chuck and extension hose long enough to allow you to stand to one side and NOT in front of or over the tire assembly. Use a safety cage if available.

Check wheels for low pressure, cuts, bubbles, damaged rims or missing lug bolts and nuts.

10. Improperly disposing of waste can threaten the environment and ecology. Potentially harmful waste used with equipment include such items as oil, fuel, coolant, brake fluid, filters, and batteries.



Use leak proof containers when draining fluids.







Do not use food or beverage containers that may mislead someone into drinking from them.

Do not pour waste onto the ground, down a drain, or into any water source.








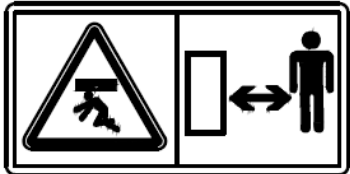

Air conditioning refrigerants escaping into the air can damage the Earth's atmosphere. Government regulations may require a certified air conditioning service center to recover and recycle used air conditioning refrigerants.

Inquire on the proper way to recycle or dispose of waste from your local environmental or recycling center, or from your East Wind dealer.









## 1.2 Safety symbols

No.	Safety symbol	Meaning	Position
1		Keep away from rotating components when the mechine is working.	On the right side of the radiator
2		Don't touch the hot surface until it's cool enough, otherwise you may be damaged.	On the right side of the radiator, near the muffler
3		Keep away from radiator. There may be hot fluids or steam	Above the radiator
4		If you want to operate Please Read the operators handbook.	On the PTO shield
5		Don't jump out of the tractor when it turns over, it may cause worse result.  Keep the ROPS in the fully extended and locked position.	On the left side of Safety Frame
6		Please fasten your seat belt.	Above the Panel

## 504G3 SERIES TRACTOR OPERATION MANUAL


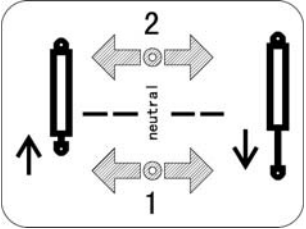
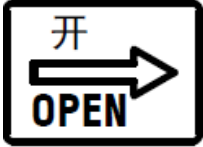







7		<p>Don't add fuel, do maintenance and so on when the tractor is running.</p>	<p>On the right windshield</p>
8		<p>Power take-off actuator and/or rotational-speed selector position: disengaged</p>	<p>Beside the PTO operating lever, on the fender</p>
9		<p>Power take-off actuator and/or rotational-speed selector position: 540rpm</p>	
10		<p>Power take-off actuator and/or rotational-speed selector position: 1000rpm</p>	
11		<p>Only ride on the operator's seat. Or it may cause serious accident.</p>	<p>on the right fender</p>
12		<p>Lifting mechanism control: raised position.</p>	<p>on the fenders</p>
13		<p>Lifting mechanism control: lowered position.</p>	<p>on the fenders</p>
14		<p>Be clear of the machine when it's lifting implements or heavies. It may cause accidents.</p>	<p>On outside surface of the squab panel</p>
15		<p>Parking brake control, Stopping and parking the machine.</p>	<p>Beside the Handle brake control lever, on the squab panel</p>

## 504G3 SERIES TRACTOR OPERATION MANUAL

16		No standing on the 3-point hitch or the shield. It may cause accident.	On the outside surface of the squab panel
17		When you see this symbols, you should read Operators handbook.	On the Panel
18		Checking and adjusting the fluid level.	Near the oil filler
19		Do not use the differential lock at high speed or on the road.	Beside the differential pedal, on the outside surface of the squab panel
20		Filling the tank.	On fuel tank cap
21		Do not trample.	Above the battery
22		Disconnect the battery before working on the machine.	Above the battery
23		Freeing a Mired Machine.	On the right outside surface of Safety Frame



## 504G3 SERIES TRACTOR OPERATION MANUAL

24		Define of Remote hydraulic valve.	Above the Rear beam
25		Define of Remote hydraulic control valve.	Above the Rear board
26		Open the engine hood.	On the engine hood.
27		Mandatory sign of front drive.	On the Seat plate.
28		Mandatory sign of support point.	On the frame, or rear axle housing, or axle shaft housing.
29		Mandatory sign of lifting point.	On the assistant weight support, or axle shaft housing
30		Mandatory sign of engine oil.	On the engine.
31		Oil filler.	On the left side of Safety Frame.
32		Escape way	Cab rear column
33			

*If you need symbols ,please give number to your East Wind dealer or employer.*

### 1.3 Measures for emergency

1. When lost of steering control, slow down the tractor, engage the emergency brake, and then shut down the engine.
2. If the engine shut down when going up the slope, step down the brake pedals immediately, and engage the park brake to avoid slipping down along the slope. Ignite the engine after that, and shift to a proper gear, then go up the slope with smooth.
3. If the brake system fails, control the steering wheel, slow down the tractor or shift to lower gear, and running the tractor in neutral, then shut down the engine in safe place.
4. When needing get out of the CAB in case of the danger, but the door of CAB can't be opened, or the door is not suitable for escaping, then open the emergency escape window behind the seat, and escape from the window.



- a. Find and rotate the handle of the emergency escape window
  - b. Push the handle backward with hand, and open the window completely
  - c. Escape from the window as soon as possible.
5. In following situations, the tractor can not be started up:
    - A. **When the brake system fails.**
    - B. **When the steering system can not be managed easily or the steering system is broken.**
    - C. **After reinstall the tractor by oneself, and there exist safety problems.**
    - D. **When you are unsure that you can control it.**
    - E. **When you are unsure that you and those around you will be safe.**

## Chapter 2 Technical Specifications

### 2.1 Tractor characteristic

DF504G3 series tractor operator see table.

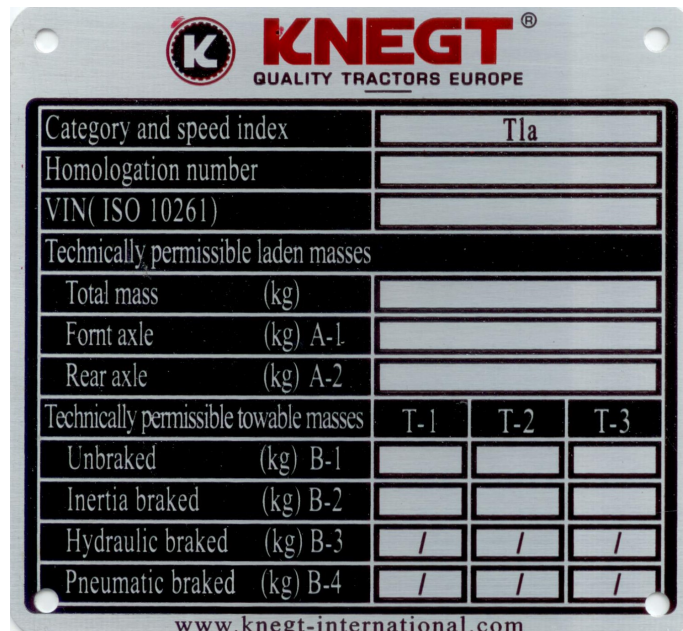
**Table 2-1 Technical Specification**

Tractor Model	Type	Engine		Type of hydraulic lift system	Control of clutch and brake	ROPS/CAB
		Rated Power (Kw)	Rated Speed (rmp)			
DF504G3	4WD	36	2400	independent	Hang	YES

### 2.2 Identifying your machine

#### 2.2.1 Machine Identification Plate

Your machine has an identification plate mounted on the front right hand side of the machine. Information contained on this plate includes Category and speed index, VIN, Technically permissible laden masses, Technically permissible towable masses, Manufacturer and Address. The machine VIN and engine serial numbers can help identify exactly the type of equipment you have.



# 504G3 SERIES TRACTOR OPERATION MANUAL

## 2.2.2 Component Identification Plates

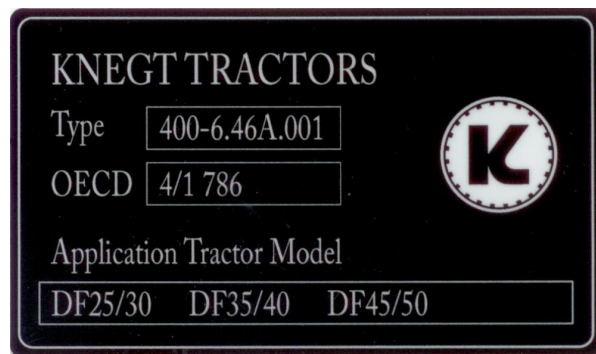
### Engine Identification Plate Location

The engine identification plate is attached to the left hand side of the engine block. The information contained on this plate includes the engine model and serial number.



### ROPS Certification Plate

Your machine is built to the ROPS standard and has an identification identification label is shown below. Label fitted to the ROPS or cab.



### Tractor Drawbar Or Clevis type Certification Plate

The Tractor drawbar or Clevis type on your machine is built to a standard and has an identification label fitted to the top of the trailer hitch. A typical identification label is shown below.

## 2.3 Technical specification of the tractor

### 2.3.1 Tractor specification

Tractor model			DF504G3	
Overall Dimensions (mm)	Overall Length		3733(front ballast to end of hitch lever)	
	Overall Width		1615	
	Overall Height	To ROPS	2502	
		To CAB	2451	
Tyre	Front		8.3-20	
	Rear		12.4-28	
Wheel track (mm)	Front		1300	
	Rear		1300	
Wheel base (mm)			1880	
Minimum ground clearance (mm)			357	
Steering radius (m) without braking			3.7	
Construction mass (Kg)	With ROPS		1955	
	With CAB		2115	
Rated draft force (N)			1000	
Theoretic speed (km/hr)	Forward	Low	I	2.13/0.25
			II	3.08/0.37
			III	4.08/0.49
			IV	5.04/0.60
		Mid	I	5.70/0.68
			II	8.24/0.95
			III	10.93/1.30
			IV	13.51/1.61
		High	I	11.64/1.38
			II	16.82/2.00
			III	22.30/2.65
			IV	27.55/3.28

## 504G3 SERIES TRACTOR OPERATION MANUAL

	Reverse	Low	I	1.94/0.23	
			II	2.81/0.33	
			III	3.72/0.44	
			IV	4.60/0.55	
		Mid	I	5.20/0.62	
			II	7.51/0.89	
			III	9.96/1.18	
			IV	12.31/1.46	
		High	I	10.61/1.26	
			II	15.33/1.82	
			III	20.32/2.42	
			IV	25.12/2.99	
Unladen mass(es): (Kg)			ROPS	CAB	
Unladen mass(es) in running order:			2135	2258	
Front axle			841	881	
Rear axle			1294	1377	
Technically permissible laden masses (Kg)					
Total mass			2415	2538	
Front axle			1009	1049	
Rear axle			1406	1489	
Permissible laden masses by tyre					
type			Allowed load	speed	
Front axle			1390	30km/h	
Rear axle			3020	30km/h	
Ballast masses (total weight, material, number of components)					
Position			Quantity	Unit weight	Total weight
Front			6	20kg	120kg
Rear			4	40kg	160kg
Distribution of this (these) mass(es) among the axles					
Front			168kg	-48kg	

## 504G3 SERIES TRACTOR OPERATION MANUAL

Rear		0	160kg	
Total		168kg		112kg
Technically permissible towable masses		T-1	T-2	T-3
Unbraked		700kg	700kg	700kg
Inertia braked	Drawbar	6000kg	/	/
	Clevis	1000kg	1000kg	1000kg
Hydraulic braked		/	/	/
Pneumatic braked		/	/	/

### 2.3.2 Engine

Tractor Model	DF504G3		
Engine Model	4G50B		
Type	Four-stroke、 water cooled、 4 cylinder、 L-type、 direct injection		
Number of cylinders	4		
Bore and stroke (mm)	95×115		
Total displacement (L)	3.26		
Compression	18.5		
Cylinder sleeve style	Dry		
Rated power/speed (kW/rpm)	36/2400		
Rate fuel consumption (g/Kw.h)	≤240		
Maximum torque (N.m)	≥183		
Dry weight (kg)	280		
External dimension (mm)	Length	820	
	Width	595	
	Height	763	

### 2.3.3 Transmission

Tractor model	DF504G3		
Clutch	Main clutch: Dry, single-acting clutch, diaphragm spring PTO clutch: Electric hydraulic control clutch		
Transmission	(4×3) ×2×2 compound shaft, Change shift with engaging sleeve in range		

## 504G3 SERIES TRACTOR OPERATION MANUAL

		shift, Change shift with synchromesh in main gear.
Main drive		Spiral bevel gear
Differential		Obturation, four bevel planetary gears
Final transmission		Planetary reduction gears
Front drive axle	Main drive	Spiral bevel gears
	Differential	Obturation, four bevel planetary gears
	Final transmission	Bevel gears
Transfer case		Vertical, column gear with shift

### 2.3.4 Travelling and steering system

Model		DF504G3
Front wheel drive axle		Bevel gear drive axle
Front axle alignment	Front wheel toe-in (mm)	4~8
	Outward camber	2°
	Kingpin caster	± 14°
	King pin inclination	9°
Tyre	Front	8.3-20
	Air pressure (Kpa)	150~250
	Rear	12.4-28
	Air pressure (Kpa)	100~200
Tyre Option	Front	280/70R18
	Air pressure (Kpa)	200~300
	Rear	360/70R28
	Air pressure (Kpa)	100~200
Steering system		Full Hydraulic steering gear
Brake		Wet disk type

### 2.3.5 Equipment

Tractor model	DF504G3
---------------	---------



## 504G3 SERIES TRACTOR OPERATION MANUAL

Hydraulic system	Pump type	CBN314 HLCB-D10-10
	Plowing-depth control	Draft and Position Control, and floatation control
	Theoretic flow	14ml/r 10ml/r hydraulic steering
	Response pressure of the safety valve	22MPa
Three point hitch		II type (GB/T1593.1-1996)
Max.lift(N)		9100(At 610mm behind the lift point)
Lift time(S)		≤3
Diameter of the hole of up lift (mm)		28.7
Diameter of the hole of down lift (mm)		22.5
Tractor	Diameter of Pin(mm)	30
Drawbar	Groud clearance(mm)	302/397
Clevis type	Diameter of Pin(mm)	40
	Groud clearance(mm)	441
PTO shaft	Type	Independent
	Rotating Speed(r/min)	540、1000
	Spline dimension	6-teeth φ35 rectangular spline
	Direction of rotation	Clockwise(face forward)

### 2.3.6 Electricity and instrument panel

Tractor model	DF504G3
Electric circuit	12V single phase & negative ground
Battery	6-QW-80L
Starter	QDJ1408F-P
Generator	JFWZ17
Instrument panel	504G3-E.48A.021
Switch Plate	JK938A
Key Switch	JK324

## 504G3 SERIES TRACTOR OPERATION MANUAL

Combination switch	DF504G3-6.48.103	
Battery switch	DHKG904	
Safety switch for transmission	KT205	
Brake switch	JK213B	
Horn	DL-124D	
Fuse	504G3.48.025	
Electrical choke	GS-1	
Flashing	SG152	
railer electrical outlet	12N	
Headlamp	H1 12V 55W White	
Front signal lamp	Position lamp	4W white
	Direction-indicator lamp	21W yellow
Rear combination lamp	Stop lamp	21W red
	Position lamp	5W red
	Direction-indicator lamp	21W amber
Work lamp	H3 12V 55W White	

### 2.3.7 Capacities

Model	DF504G3
Fuel tank(kg)	34
Engine coolant(kg)	14
Engine crankcase(kg)	5
Transmission and rear axle case(kg)	30
Front axle case(kg)	5.5
Steering tank	3

### 2.3.8 Farm implements to be attached

Name	Specification
Plough	1L-230 1L-330 1LT-335 1LQ-425
Disk plough	1LYQ-525/625 1LY-2-25

## 504G3 SERIES TRACTOR OPERATION MANUAL

Rotary cultivator	1GN-150	1GN-160	1GN-175	1GQN-180
Disk harrow	1BSQ-21	1BSQ-23/23A		
Rotary seed drill	2BGS-10/12/14			
Straw cutter	1GF-160			
Combine harvester	Guiling II	Xiangming 4L-1.5/4L-2.5A		
Trailer	7C-5 tons	7C-6 tons		
Seeding-machine	2B-16	2BQ-6A	2BY-6A	BG-24A
Ditching -machine	1K-30	1K-35	1KH-35	
Disc harrow	1BJX-1.8	1BJX-2.2		
Grab	1W-60	1W-70		

### 2.3.9 Noise

In accordance with Regulation (EU) 2015/96 ANNEX III External sound emission requirements and Regulation (EU) No 1322/2014 ANNEX X III Requirements applying to the driver's exposure to noise level

	DF504G3	Max. permissible value in Directive
SOUND LEVEL (EXTERNAL)环境噪声	82.8 dB(A)	89 dB(A)
SOUND LEVELS (INTERNAL)耳旁噪声	85.6 dB(A)	86 dB(A)

### 2.3.10 Vibration

In accordance with Regulation (EU) No 1322/2014 ANNEX X IV Requirements applying to the driving seat

4.4.1 The arithmetic mean of the rms values of the weighted seat vibration acceleration  $(aw_S) \leq 1.25 m/sec^2$ .

Class	I
Light driver	0.60
Heavy driver	1.15

4.4.2 Ratio of the arithmetic mean of the rms values of the weighted vibration acceleration measured on the seat ( $aw_S$ ) to the arithmetic mean of the rms values of the weighted vibration acceleration measured at the seat attachment ( $aw_B$ )

## 504G3 SERIES TRACTOR OPERATION MANUAL

---

$awS/awB \leq 2$

Class	I
Light driver	0.996
Heavy driver	1.070

## Chapter 3 Running-in of the tractor

In order to prolong the service life of tractors, it is essential to break-in a new tractor or the engine after a major overhaul, before putting it into service. Breaking-in improves all of the fittings and contact surfaces in order to avoid premature failures.

### 3.1 Preparation before Running-in of the tractor

1. Please check and tighten the outside screws.
2. Add grease into all the grease fittings.
3. Check the oil level of engine, gearbox and rear axle, final transmissions, front wheel drive axle, steering oil tank and hydraulic system. If it is not enough, then supply again.
4. Fill some fuel and cooling water.
5. Check air pressure of the the tires.
6. Check proportion and height of battery electrolyte.
7. Put Shuttle shift lever, range shift lever and gear shift lever on “netural” position. Disengage the 4WD. Switch off the PTO switch.

### 3.2 Running-in the engine without load

Running-in engine for 15 minutes without load. Start the engine in accordance with the procedure specified in the Instruction Manual, let the engine running-in 7 minutes in hight speed, 5minutes in mid speed, 3 minutes in high speed.

During the running-in of engine without load, should carefully check the work condition of engine, air compressor and hydraulic pump. Observe if have abnormality, noise and check leakages of water, oil and air. If the meters work abnormally, should stop and remedy the trouble to restart running-in when find abnormality.

Running-in as below when you confirm the engine working is abnormal.

### 3.3 Running in of hydraulic hitch system

1. Attach ballast or implement whose weight is 800Kg to 3 point hitch system. Push the position control lever forward all the way to its lower position.
2. Run the engine in low speed for 10 min and in high speed for 10 min.
3. Pull the position control lever backward all the way to its max lift position. Then control the draft control lever to make the ballast or implement moving from highest position to lowest position for 10 times.
4. Place the draft control lever in its lowest position. Then control the position control lever to make the ballast or implement moving from highest position to lowest position for 10 times. Check whether the position control lever in any position needed.
5. If hydraulic system operate hardly and lift or low hardly, check trouble immediately.

### 3.4 Running-in of hydraulic steering system

- (1) Park the tractor on the flat road.
- (2) Start the engine , let the engine work in low speed, mid speed and high speed. Turn the steering wheel left and right steady in proper order to do ten times pivot steering. Check whether the steering is flexible and portable. Check whether the steering system has oil leak, oil infiltrate and abnormal noise. During the Running-in of hydraulic steering system, the malfunction should be eliminated in time.
- (3) After the engine shutdown, turn the steering left and right slowly , observe the follow-up condition of tractor front wheel steering to check whether it can realize the manpower turn .When turning the steering ,do not apply impact force to the steering wheel.

### 3.5 Running in of PTO

Put the throttle handle of engine into medium position, the engine will run in idle speed, switch on the PTO switch to engage PTO clutch. Let the PTO shaft running-in for 5 minutes respectively at low speed and high speed by shifting PTO lever to “LOW” or

## 504G3 SERIES TRACTOR OPERATION MANUAL

“HIGH” position. Check if it is abnormal and must make PTO shaft at Neutral position after running-in.

### 3.6 Running in of the Tractor

When operating the tractor with a load during the running-in process, the load must be added from light to heavy and the gears must be changed gradually from low to high. Also you must steer and turn the tractor often while performing the above procedures. The total time needed to running-in the tractor with a load is 50 hours. The running-in criteria are as follows:

	Gear			Draft( KN)				Total time(h)
				Without load	2.5	5	7.5	
Time (h)	Forward	L	I	0.5	1	1.5	1	52
			II	0.5	1	1.5	1	
			III	0.5	1	1.5	1	
			IV	0.5	1	1.5	1	
		M	I	0.5	1	1.5	0.5	
			II	0.5	1	1.5	0.5	
			III	0.5	1	1.5	0.5	
			IV	0.5	1	1.5	/	
		H	I	0.5	1	0.5	/	
			II	0.5	1	/	/	
			III	0.5	1	/	/	
			IV	0.5	1	/	/	
	Reverse	L	I	1	1	0.5	0.5	
			II	1	1	0.5	0.5	
			III	1	1	0.5	0.5	
			IV	1	1	0.5	0.5	
	Creep	L	I	0.5	1	1	0.5	

## 504G3 SERIES TRACTOR OPERATION MANUAL

			II	0.5	1	1	0.5	
			III	0.5	1	1	0.5	
			IV	0.5	1	1	0.5	

The front drive axle's running-in is only allowed in fields or dirt roads. Only low III gears can be used to running-in while the front drive axle is joining. Disengage the front drive axle before the other gears running-in.

Attention must be paid to the process of the running-in:

- (1) Whether the engine is running properly.
- (2) Whether the clutch joint is smooth and whether the separation is complete.
- (3) Whether the transmission of gearbox and changing gear is smooth、light. Whether the gearbox has disorderly shop, automatic stripping phenomenon
- (4) Whether the brake is reliable.
- (5) Whether the front drive axle joint and separate is reliable.
- (6) Whether the PTO's joint and separation is reliable.
- (7) Whether the differential lock joint and separate is reliable.
- (8) Whether the electrical equipment and all kinds of instrument is working properly.

In process of running-in, if abnormal phenomena are found, the cause should be found, and the running-in can be continued after the discharge.

### 3.7 Maintenance after running-in

After running-in, metal powders and dust will produce in the lubricant oil in the transmission system. All lubricating oil and hydraulic oil should be cleaned and replaced, carry out necessary technical maintenance before put tractor into normal use.

1. After the engine shutdown, drain out the oil in the sump and steering system when it is still warm. Clean sump, oil filter, diesel filter, air filter and filter net in the steering oil tank, after replace the core of diesel filter and oil filter, refill new oil as per specified.
2. Drain out the oil in the transmission system and front axle when it is still warm; meanwhile refill reasonable light diesel or kerosene. If the engine does not start, use slow speed drag tractor forward or backward about 3 minutes or lift the front



## **504G3 SERIES TRACTOR OPERATION MANUAL**

---

and rear tires to leave ground. Turn front and rear tires about 3 minutes in two directions, instantly drain out the cleaning liquid. Meanwhile dismantle inlet oil filter or lifter to clean, refill new oil to transmission system, lifter and front axle as per specified after reinstall well.

3. Drain out coolant and after clean cooling system by water.
4. Clean diesel filter and air cleaner.
5. Check front toe-in, clutch, and the free path of brake, adjust it if necessary.
6. Check and fasten all outside bolts, nuts and screws.
7. Check the nozzle and valve clearance.
8. Check the working of electrical system.
9. Refill lubricant grease to each part of the tractor.

## Chapter 4 Operating tractor

### 4.1 Instrument and Controls

To prevent from accident, it is necessary that you are familiar with instrument and controls.

#### 4.1.1 Tractor Controls



Fig.4-1 Controls

## 504G3 SERIES TRACTOR OPERATION MANUAL

1. Shuttle Shift Lever 2. Clutch Pedal 3. Mid PTO Lever 4. FWD Lever 5. Hand Brake Lever 6. Creer Shift Lever 7. Rear PTO Lever 8. SCV I Lever 9. SCV II Lever 10. Rapid Lift Lever 11. Range Shift Lever 12. Position Control Lever 13. Draft Control Lever 14. Gear Shift Lever 15. Foot Throttle 16. Brake Pedal 17. Hand Throttle 18. Steering Wheel

### 4.1.2 Instrument Panel and Switch



**Fig.4-2 Instrument panel and switch**

- 1. Instrument Panel
- 2. Grouped Switch
- 3. Switch Plate

### 1、 Ignition Switch



**Fig.4-3 Ignition switch**

- 1. OFF Position
- 2. ON Position
- 3. Preheat
- 4. Start Position

OFF Position(1)—Turn key to OFF position from ON position to stop engine

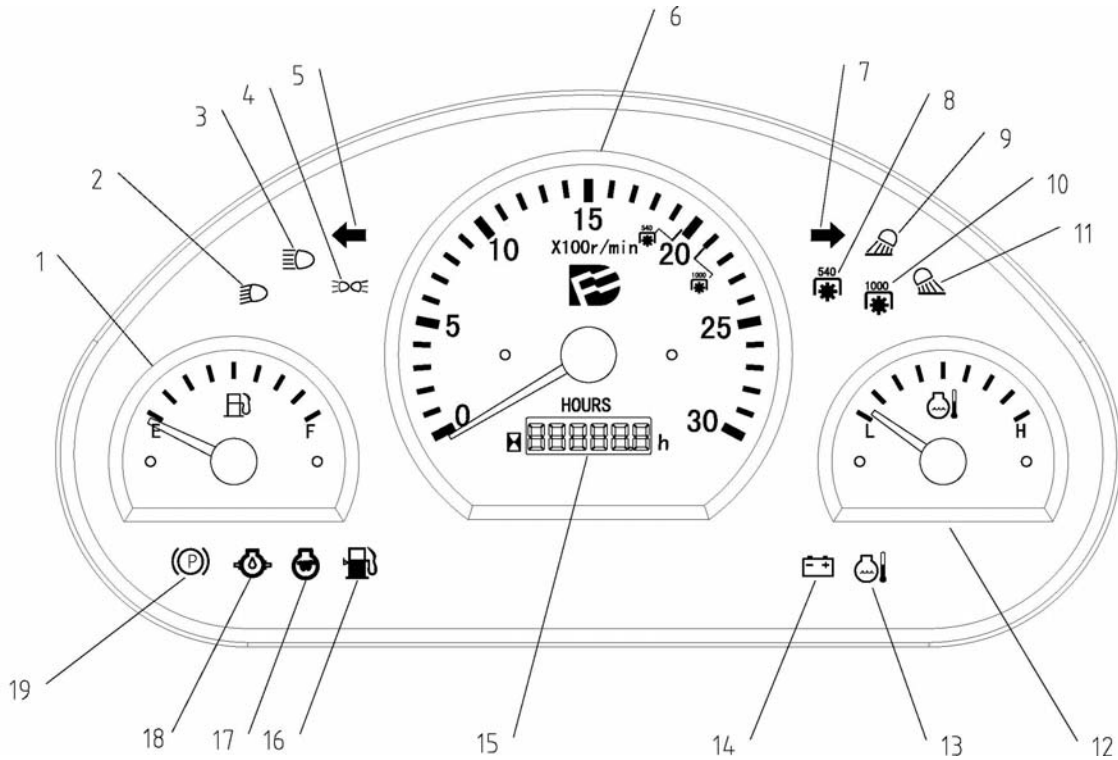
ON Position(2)— After turn key to Start position and releasing key, key returns to ON position.ON position enables on circuit allowing engine to run.

## 504G3 SERIES TRACTOR OPERATION MANUAL

Cold Weather Start(3)—Preheat before start engine in cold weather. Refer the section“Start in cold weather” in this chapter.

Start Position(4)—Turn key to start position to start engine.

### 2、 Instrument Panel



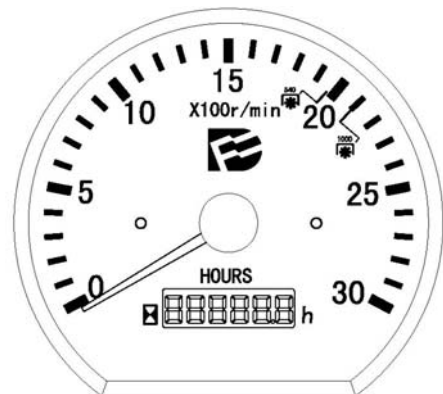
**Fig. 4-4 Instrument Panel**

1.Fuel Gauge 2. Dipped Beam Indicator 3. Low pressure Indicator 4.End-Outline Position Indicator 5. Left Turn Signal Indicator 6. Tachometer 7. Right Turn Signal Indicator 8. PTO Monitor Indicator for 540 rpm 9. Headlight Indicator 10. PTO Monitor Indicator for 1000 rpm 11. Tail Lamp Indicator 12. Coolant Temperature Gauge 13. Temperature Indicator 14. Charge Indicator 15. Hourmeter 16. Fuel Indicator 17.Electrical preheat Indicator 18.Engine Oil Pressure Indicator 19.Brake Indicator

#### **Tachometer and Hourmeter**

Tachometer shows engine revolutions per minute, read in hundreds.

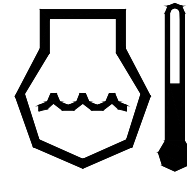
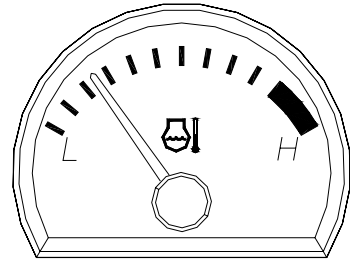
Hourmeter shows hours of engine operation in full hours and tenth. White mark shows the rotational speed of engine. Blue mark shows the rotational speed of PTO.



## Coolant Temperature Gauge

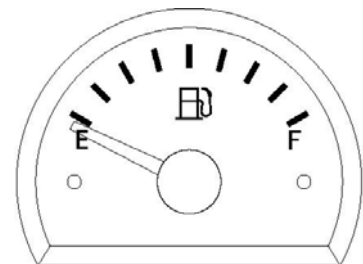
Coolant temperature gauge shows the temperature of the engine coolant. The temperature of green zone is 40 °C ~100 °C, and red zone is 100 °C~115 °C.

The normal temperature of engine coolant is 70 °C~85 °C. The most temperature is not over 95 °C. If the coolant temperature gauge goes into the red zone, the coolant temperature alarm will light. In the case, stop engine and determine the cause.



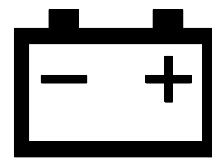
## Fuel Gauge and Fuel alarm

Fuel gauge shows the quantity of the fuel. The letter "F" means full and "E" means empty. If the fuel gauge goes into red zone, the fuel alarm will light. You should add fuel to fuel tank.



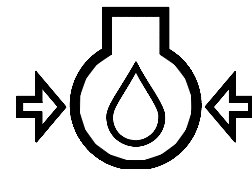
## Charge Indicator

Charge indicator lights when key is turned to START position and goes out after engine starts. If charge indicator stays lit for longer than 5 sec, please stop the engine and check for cause.



## Low Pressure Indicator (Red)

Low pressure indicator shows should glow when the pressure of engine lubrication system pressure is under 0.1Mpa so that engine should be stopped and checked. When idle engine, low pressure indicator may light.



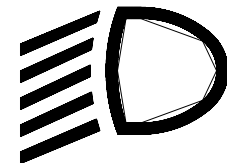
## High beam Indicator (Blue)

High beam Indicator should glow when high beam switch is switched to beam position.



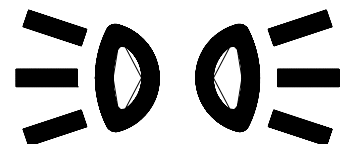
## Dipped-beam Indicator (Green)

Dipped beam indicator should glow when dipped beam switch is switched to beam position.



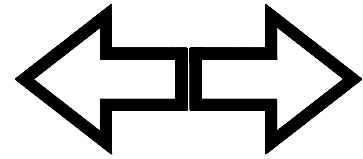
## End-outline Maker Indicator (Green)

End-outline maker indicator lights when the main beam lamps are lit.



**Left and Right Turn Indicators (Green)**

Left and right turn indicators lights when left or right indicator lamp is lit.



**Brake Indicator (Red)**

Brake indicator lights when brake is depressed. At one time, the brake lamp will light.



**PTO Monitor Indicator for 540 rpm**

Indicates the state of the PTO shaft as follows:

- If the monitor glows, the PTO shaft is rotating at speed of 540 rpm.

540



**PTO Monitor Indicator for 1000 rpm**

Indicates the state of the PTO shaft as follows:

- If the monitor glows, the PTO shaft is rotating at speed of 1000 rpm

1000



**Electrical preheat Indicator**

When ignition switch is on 'Preheat' position, thi indicates is working.



**Headlight Indicator and Tail Lamp Indicator**

Headlight Indicator should glow when Headlight switch is switched to beam position.

Tail Lamp Indicator should glow when Tail Lamp switch is switched to beam position.



**3、Combination Switch:**



**Fig.4-5 Combination switch**

- 1. Turn indicator switch**
- 2. Horn switches**
- 3. Main beam switch**

Turn indicator switch 1 is used to switch on the right or left turn indicator lamp. Turn switch 1 clockwise to switch on right indicator lamp. Turn button 1 counterclockwise to switch on the left indicator lamp. Turn indicator switch is not functional when hazard warning signals flashing.

Switch off hazard warning signal with hazard warning switch before operating turn

indicator switch.

Push down horn switch 2 to switch on horn. The button 2 will return to initial position after releasing.

Turn main beam switch 3 to control the main beam lamp.

#### 4、 Switch plate:



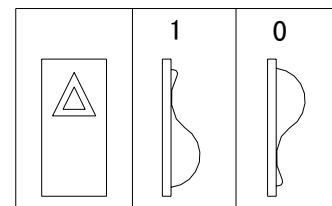
**Fig.4-6 Switch plate**

- 1. Hazard-warning signal Switch
- 2. PTO Switch
- 3. Rear Work Lamp

#### (1) Hazard-warning signal switch

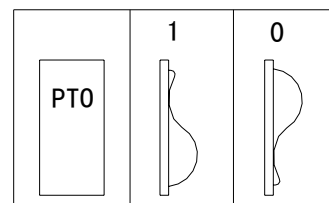
It is only used to switch ON the hazard-warning signal.

Hazard-warning signal should light when tractor should be repaired on road or running in night. “1” is ON position.



#### (2) PTO Switch

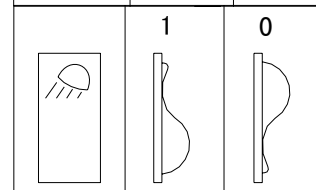
It is only used to engage PTO. When the speed of PTO shaft should be changed, place switch on “0” position where PTO is disengaged.



#### (3) Rear Work Lamp Switch



It is only used to switch on the rear work lamp. “1” is ON position. Rear work lamps are installed on left and right fenders.



**Fig.4-7**

- 1. Rear Work Lamp

**5、 Functions of the switches in cab:**



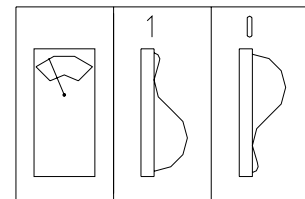
**Fig 4-8**

**1. Windshield Wiper Switch**

**2. Heater Switch**

**(1) Windshield Wiper Switch**

This switch controls the windshield wiper. See figure at right, “0” position means turn off the switch, and “1” position means turn on.



**(2) Heater Switch**

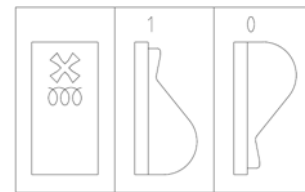
This switch controls the heater for the CAB/

The heater heats the CAB with hot water from engine radiator.

See figure at right, put the switch on “1” position to engage the

heater, the warm wind will be blown out form the air outlet in CAB.

And“0” position to turn off the heater.



**(3) Use and adjustment of system for heating**

a. Firstly check the hose fixed on the engine, and make sure it is reliable. and check the hose clamps, make sure it is fixed and reliable. See figure at right.



b. Starting the engine and keep the idle speed state 5 minutes, then press down the

heater switch. The warm wind will be blown out form the air outlet in CAB.

c. There are six circular outlets in CAB, and each outlet can be opened or closed. See figure at right.





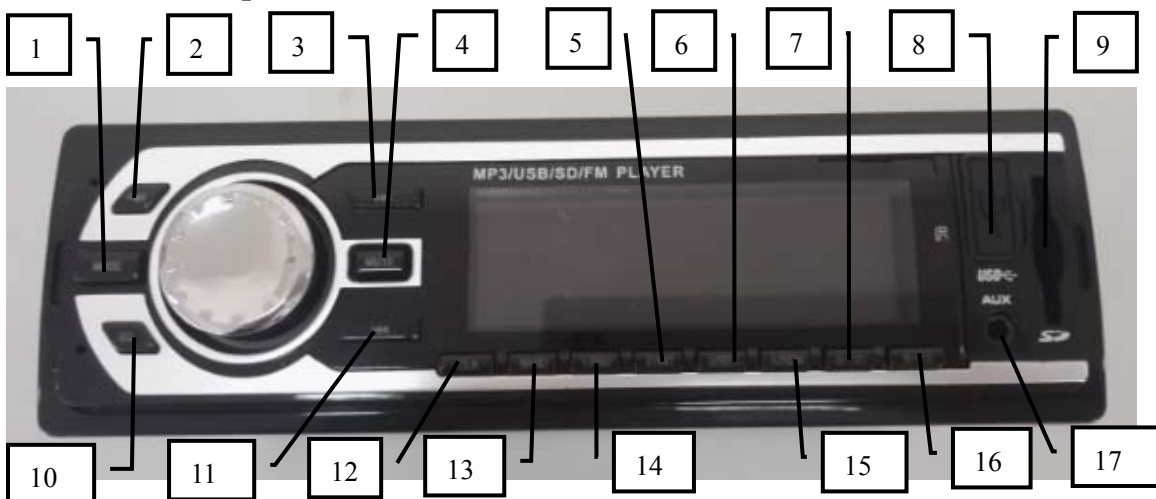
d. There are two rectangle outlets in CAB, the windowing blade can swing up or down and left or right, to adjust the wind direction.



e. There are two strip outlets in CAB, they are used defrosting for Windshield.



### 6、 Radio control panel in CAB



**Fig. 4-9**

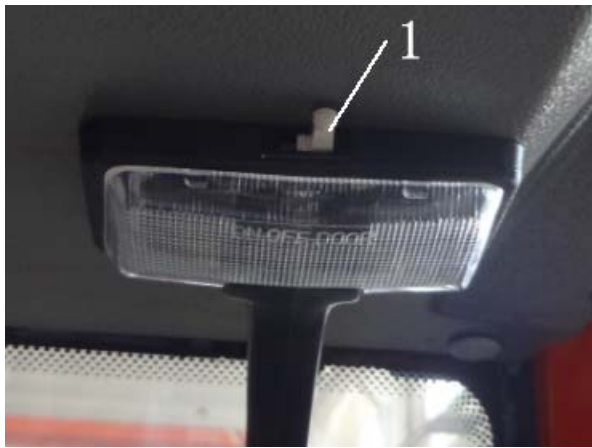
- 1. Mode Switch    2. Power Switch    3. Radio selection-/Next track    4. Mute the sound
- 5. Preset station 2/INT    6. Preset station 3/RPT    7. Preset station 5/10-    8. USB SLOT
- 9. SD/MMC CARD PORT    10. Sound Files/Automatic preset station    11. Radio selection+ /previous track
- 12. Clock function/According to three seconds clock adjust
- 13. Radio band selection    14. Preset station 1 /Player pause    15. Preset station 4/RDM
- 16. Preset station 6/10+    17. AUX/IN

### 7、 Radio horn

Above the back of the CAB, there are two loudspeakers. When opening the radio, the sound will come out from the loudspeaker.



### 8、 Switch of the lamp on the roof in cab



**Fig. 4-10**

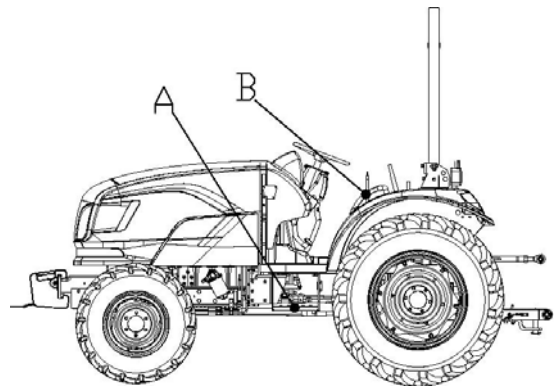
**1. Switch of the lamp on the roof**

This switch controls the lamp on the roof. Turn on the lamp when driving the tractor at night.

### 4.2.1 Getting on and leaving the tractor

#### Tractor With Rops

Getting on or leaving the tractor must only be made where steps (A) and handrails (B) are provided. Always face the machine when entering and leaving. Make sure the step(s), handrails and your boot soles are clean and dry.



**Fig.4-11**

#### Tractor With CAB)

a. When getting on the tractor, open

the door of CAB, keep feet on the step ladder, and hold the handle 1 and handle 2, then stand on the floor, hold the steering wheel and sit on the seat.

b. When leaving the tractor, get up from the seat, and open the door of CAB, hold the handle 1 and handle 2 and put the feet on the step, then get down from the step. And finally close the door.

Do not jump from the machine. Do not use the machine controls as handholds, use the handrails.

**Make sure the machine is stopped and correctly parked before entering or leaving the cab or tractor.**



**Fig.4-12**

### 4.2.2 Adjust Seat and Steering Wheel

**Do not adjust the seat and steering wheel when the machine is in operation.**

The operator's seat can be adjusted for your comfort. A correctly adjusted seat will reduce operator fatigue. Position the seat so that you can comfortably reach the machine controls. For driving the machine, adjust the seat so that you can depress the pedals fully with your back against the seat back.

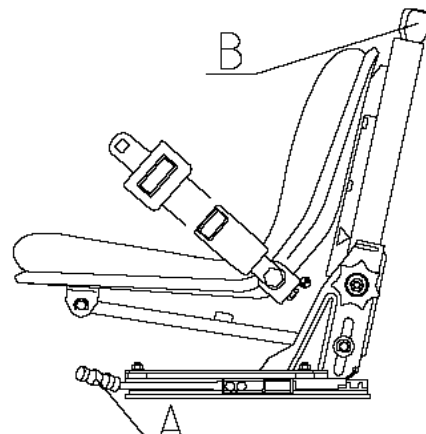
- **Use operator's set**

The operator's seat can be adjusted for your comfort. A correctly adjusted seat will reduce operator fatigue. Position the seat so that you can comfortably reach the machine controls. For driving the machine, adjust the seat so that you can depress the pedals fully with your back against the seat back.

#### 1. Fore/Aft Adjustment

- a) Lift handle A upwards and slide the seat forwards or backwards to the required position.
- b) Release handle A and make sure the seat locks into position.

#### 2. Height Adjustment



**Fig.4-13**

a) With the seat unloaded, turn the knob B in the required direction to raise or lower the seat.

b) Raise or lower the seat until a clear view is achieved.

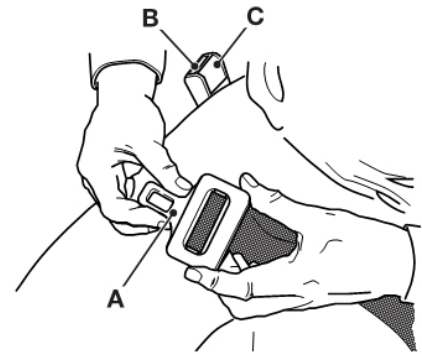
### • Seat Belt

1. Fasten the Seat Belt

a) Sit correctly in the seat.

b) Push the male fitting A into the buckle B until it latches into position.

Make sure the seat belt is not twisted and that it is over your hips not your stomach.



**Fig.4-14**

2. Release the Seat Belt

Press button C and pull the male fitting A from the buckle B.

### • Steering Wheel



**Fig.4-15**

1. Adjustment handle

2. Steering Wheel

Steering wheel can be adjusted forward or backward to make the operation of tractor satisfactorily by following steps.

- (1) Depress the the adjustment handle.
- (2) Pulling the steering wheel backward or pushing it forward as your need.

### 4.2.3 Operating the Engine


- **Service Daily Before Start-Up**

Park the tractor on flat ground before executing check. Check engine oil level. Remove and clean the dipstick and reinsert fully. Remove and check the oil level. The safe operating range is between upper and lower marks on the dipstick.

Do not operate the engine if the oil level is below minimum mark. In this case, add recommended oil.

- (1) Check prefilter of air cleaner.
- (2) Check transmission/hydraulic oil level. Remove dipstick and clean it and reinsert fully. Remove and check the oil level. Oil level should be between upper and lower marks on the dipstick. If low, add oil.
- (3) Drain water and sediment from fuel filter.

- **Before Starting the Engine**

 **CAUTION:** Prevent asphyxiation. Engine exhaust fumes can cause sickness or death to you or someone else. If you must operate engine in a building, be positive there is adequate ventilation. Either use an exhaust pipe extension to remove the exhaust fumes or open the doors and windows to bring enough outside air into the area.

- (1) Check fuel gauge to be sure that tractor has plenty of fuel.
- (2) Place shuttle shift lever in neutral, "N" position, and PTO switch in disengage position. Starter does not operate if shuttle shift lever and PTO switch are not in these position.
- (3) Place rock shaft position control lever in lower position.
- (4) Check charging system (battery) and oil pressure indicators. They glow when ignition switch is turned to ON position. If any indicators do not function properly, see your Knegt Dealer.

- **Start the Engine**

## 504G3 SERIES TRACTOR OPERATION MANUAL

---

NOTE: If temperature is below 5°C, refer to cold weather starting procedure in START IN COLD WEATHER section.

- (1) Pull hand throttle backward to about mid of lever travel to increase engine speed. Engine does not start with throttle pushed up.

**⚠ CAUTION:**

- 1) Avoid possible injury or death for the sake of a machine runaway. Do not start engine by shorting across starter terminals. If normal circuitry is bypassed, machine starts in gear and moves.
- 2) Start engine only from seat with transmission in neutral. Never start engine while standing on ground.

**⚠ IMPORTANT:** Do not run a cold engine at full throttle.

- (2) Make certain Shuttle shift lever in Neutral, N position, and creeper gear shift lever in High position, and the PTO switch in OFF position. Depress clutch pedal and turn key in ignition switch fully clockwise to START position. Release key when engine starts. If key is released before engine starts, wait until starter and engine stop turning before trying again. Check all indicators are off after engine starts.

**⚠ IMPORTANT:** DO NOT operate starter more than 15 seconds at a time. If engine does not start, wait at least 2 minutes for starter motor to cool before trying again. If engine does not start in three attempts, refer to TROUBLE SHOOTING section.

- **Start in Cold Weather**

**⚠ CAUTION:** Never use any starting fluid when starting the engine using the cold weather starting aid. The heating coil in the device may cause such flammable material to ignite, result in bodily harm or damage to machine.

- (1) Proceed as instructed in Before Starting the Engine and up to starting the Engine, step 1, in this section.
- (2) Turn ignition key clockwise to Preheat position, hold key in this position in between 20-25sec, then turn key fully clockwise to START position.

**⚠ IMPORTANT:** If engine fails to start, do not operate starter for more than 30sec at a time. Turn key back to OFF position and wait at least 2 minute before trying again, allow starter motor to cool off.

After engine starts, do not adjust hand throttle lever. Let engine run for 3-4 minute, or if


the temperature is below 0°C, extend warm-up period accordingly.

- **Check Instruments after Starting**

IMPORTANT: If charging system indicator or oil pressure indicator remains ON, or if coolant temperature gauge goes into the red zone, stop engine and determine the cause.

- (1) **Oil Pressure Indicator**

Oil pressure indicator lights and stay lit when engine oil pressure falls below minimum.

 **IMPORTANT:** Never operate engine without sufficient oil pressure. If indicator light stays lit for longer than 5 seconds under normal operating conditions, stop engine and check for cause.

If low oil level is not the problem, see your Knecht dealer.

- (2) **Charging System Indicator**

Charging system indicator lights when alternator output is low. Charging system indicator lights when key is turned to ON and START position, and goes out when engine starts. If indicator light stays lit for longer than 5 seconds under normal operating conditions, stop engine and check for cause.

If loose or broken fan belt is not the cause, see your Knecht dealer.

- (3) **Coolant Temperature Gauge**

The needle on the temperature gauge rises as engine warms up. If needle reaches to red zone, stop engine and determine the cause.

Check coolant level in radiator when engine cools. Also check front grille, radiator for plugging. Check fan belt tension. If problem is not corrected, see your Knecht dealer.

CAUTION: Do not remove radiator cap until coolant has had a chance to cool down.

Always loosen radiator cap slowly to relieve excess pressure.

- (4) **Watch Fuel Level**

Stop to refuel before needle on fuel gauge reaches empty mark.

If tractor run out of fuel and not start in several tries, air must be bled from fuel system.

( See Bleed Fuel System, in Maintenance-Fuel System section )

- **Warm Up the Engine**

The throttle should be reduced immediately after starting engine. Idle the engine at about 1500 rpm for several minutes. Run engine at a low speed and under light load until coolant reach 60°C.

### 4.2.4 Start the Tractor

1. Loose the park brake system and press the horn then check the surroundings.
2. Depress the clutch pedal to the end, shift to a proper gear. If it fails, then loose the clutch pedal, and do these procedures again.
3. Step up the tractor, and loose the clutch pedal slowly at the same time.

### 4.2.5 Driving the Tractor

1. Operate Transmission

Range shift lever provides three speed ranges: H, M and L.

Gear shift lever provides four speed ranges: 1st, 2st, 3st and 4st.

Shuttle shift lever provides two speed ranges: Forward, Reverse and Netural.

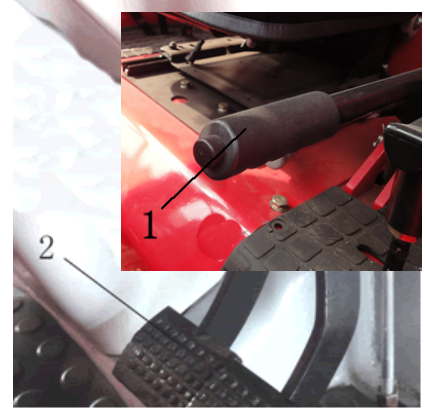
Creere shift lever provides two speed ranges: Low and High.

Using Range shift lever, Gear shift lever, Creere shift lever and shuttle shift lever in different combination, twenty-four forward speeds and twenty-four reverse speeds can be obtained.

Select the proper gear. The proper gear should be selected in order to let the engine work within 80% of the maximum power. When rototilling, place range shift lever in L or H, Gear 1st, 2st or 3st.

Gear IV, V or VI should be used for the power-driven harrow. Gear VI, VII or IX should be used for plowing and towing and use Gear X , XI or XII for hauling.

2. While operating do not ride the clutch (in other words do not keep your foot on the clutch pedal) or control speed with the clutch. If you ride the clutch or use it to control your speed the clutch will get overheated and damaged.
3. In field operation single side braking may be used to reduce the turning radius. When emergency braking, depress the clutch pedal and brake pedal at the same time. NEVER step on the brake pedal only, or you will cause damage to the brake and other parts.
4. Close the hydraulic locking valve and switch off the PTO switch to disengage the PTO shaft when traveling for a long distance with a mounted implement.




**Fig.4-16**

1. Park brake control lever


2. Brake pedals



5. When using the tractor in a dry field you may install the rear wheel balance weight (optional) in order to make full use of the traction force.

 **NOTE:** when the main speed should be shifted, the creeper should be put on the high gear (rabbit), and if the range should be shifted, then put the main speed in neutral.

- **Use of the Brakes**

 **CAUTION:** Before operating a tractor on a road, interlock brake pedals together with locking bar. Use brakes lightly and cautiously at transport speed.


For field work, brake pedals should not be interlocked together. Instead, apply right brake pedal to assist in making sharp right turn and left pedal for sharp left turn.

To stop a tractor, interlock brake pedals together with locking bar, depress brake pedals. Put gear shift in “Neutral” position and shuttle shift in “Neutral” position, then pull the hand brake lever up fully.

- **Use of the Differential Lock**

When one wheel starts to lose traction, you can engage the differential lock as following steps:

- (1) Stop the tractor.

 **NOTE:** Tractor wheels must be stopped or turning at the same speed before engaging differential lock. If possible, engage differential lock before entering the area where tires may slip.

- (2) Depress clutch pedal, place creeper shift lever in “rabbit” position, range shift lever in “L” position, and gear shift lever in “I” position.
- (3) Depress differential lock pedal down.
- (4) Slowly loosen clutch pedal. Then tractor will run out of the area where tires slip. If tires repeatedly slip, then get traction, and then slip again, hold pedal in the engaged

position.

**Note:** Unequal traction keeps the lock engaged.

When traction equalizes, lock disengages itself by spring action. If lock does not disengage, depress one brake pedal and then the other.

**⚠CAUTION:** Do not operate tractor at high speed or attempt to turn with differential lock engaged. To prevent damage to drive train, do not engage differential lock when one wheel is spinning and the other is completely stopped.

- **Use of the 4WD**

When driving on icy, wet or gravel surface, reduce speed and be sure tractor is properly ballasted to avoid skidding and to prevent loss of steering control. Front wheel drive provides better control under these road conditions.

MFWD can be engaged or disengage while in motion. See following steps:

(1) Depress the clutch pedal, then slowly release the clutch pedal, and push the 4WD Lever down to engage 4WD in time. So tractor is in 4WD mode.

(2) When stop or shift the gear, depress clutch pedal,

firstly pull the 4WD lever up to make 4WD disengage, then gear off and shut down the engine or gear up needed gear.

**⚠Caution:** 4WD greatly increases traction. When using this option, extra caution is needed on slopes. Compare to two wheel drives, front wheel drive maintains traction on steeper slopes, increasing the possibility of a tip over.

**Important:** To extend service life of front tires life, engage front drive only when needed in the field. Front tires turn slightly faster than rear tires with 4WD engaged and will wear very quickly if driven in 4WD mode on hard surface for an extended period. Unless absolutely necessary, do not engage 4WD when driving on hard surface.

- **Use of the hydraulic steering system**

**⚠CAUTIONS:** Pay attention to the following messages to keep your safety and the good condition of the tractor.



- (1) Don't turn the steering wheel with force if it's hard to turn the wheel. At first you should check the system and eliminate problems.
- (2) If the steering pump is broken or the engine can not work, and the tractor must be moved away, you should turn the steering wheel slowly. No sudden force is allowed, or the components of the steering system may be damaged.
- (3) Do not remove and adjust the steering pump by oneself. It may change the pressure of the valve.

### **CAUTION:**

- (1) When the tractor travels at a high speed, don't make an emergency turn with single brake.
- (2) If the steering angle of the front wheels is too big, and there is a noise in the valve, you should turn the steering wheel back a little to prevent overload of the hydraulic system.

#### • **Use of the tires**

As the damageable parts of the tractor, tires should be paid attention on their maintenance to extend their life.

Inflate the tires according to the regulations, if the pressure is too low or too high is not permit.

Avoid travelling over the barrier at a high speed.

The tires should be kept away from chemic stuff, such as acid and oil.

Check toe-in to avoid unnatural wear of tires. If the wear is asymmetric, exchange the left and right tire.

When mounting the tire, pay attention to direction of the tire pattern.

#### **4.2.6 Stopping Tractor**

 **CAUTION:** Always pull up the Park Brake Lever fully before dismounting.

Leaving transmission in gear with engine off may not prevent tractor from moving.

1. Reduce the throttle to slow down the tractor.
2. Depress the clutch pedal and depress the brake pedal to stop the tractor, and then place the gear shift lever and Shuttle shift lever in "Neutral" position. And then loosen the clutch and brake pedals.
3. Pull hand throttle down to slow idle position. Allow engine to idle for 1 to 2 min.

Wait the temperature of coolant decrease to below 70°C.

**▲IMPORTANT:** Engine oil provides cooling of certain engine parts. Stopping a hot engine suddenly could damage these parts by overheating or lack of lubrication.

4. Turn key switch to STOP position. Then remove key from key switch to prevent operation by untrained personnel.
5. If place the tractor on a slope, please pull up the hand brake lever fully.
6. Drain off the cooling water in winter.

**▲CAUTION:**

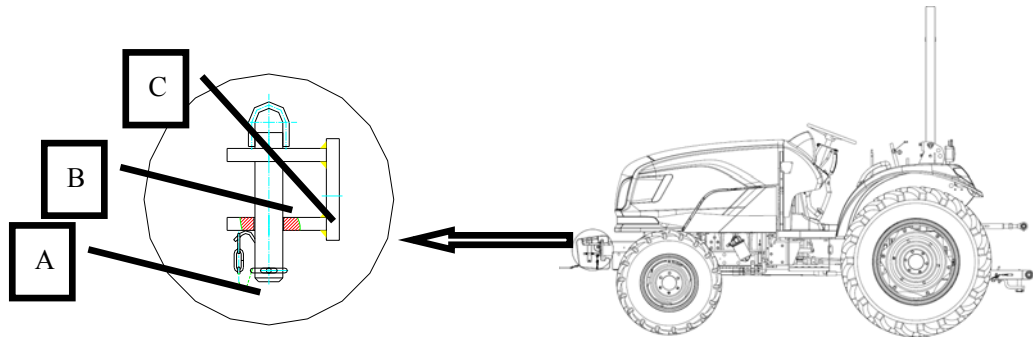
- (1) The operator can not leave with the engine on. And it's necessary to keep the shuttle and main gear shift levers in neutral.
- (2) If the tractor stopped on a slope, the engine must be shut down. At the same time, shift the shuttle and main speed into gear (upgrade with the shuttle forward and downgrade with the shuttle reverse). Lock the tires with chocks.

### 4.2.7 Draw the Tractor

1. Turn switch key to OFF position.
2. Place Shuttle shift lever in Neutral position, Creer shift lever to "Neutral" position, Range shift lever in H position, Gear shift lever in "Neutral" position
3. The draw speed must be lower than 18 km/h.

#### How to draw the tractor

You have two ways for draw tractor, you can use hook catch B (Bolt weldment) and also you can put rope to C area: you should take out A (Pin) from B, then take out B, and put rope to C area, then install B and A.



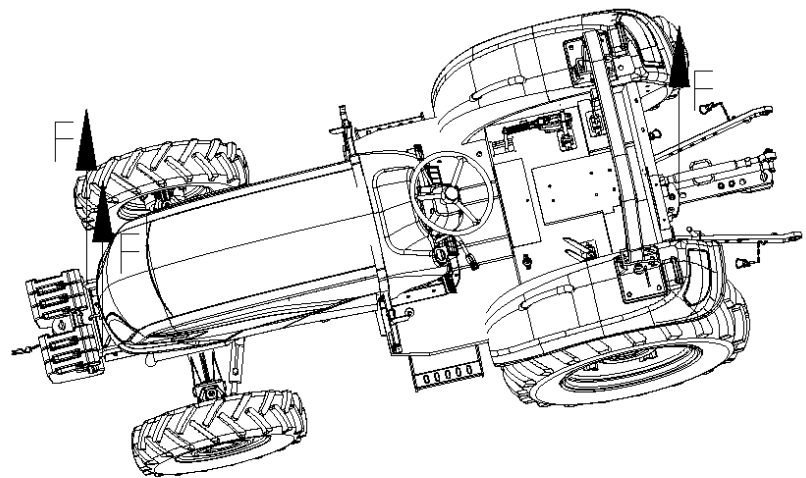
**Fig.4-17**

## 4.2.8 Hoist tractor

When you want hoist tractor, you should bundle up the hoisting slings scurely and suspend such as fig.4-18. Front suspend on Frame,Rear suspend on Drawbar.

After mak sure the hoisting slings is confirmed, hoist slowly and move the tractor Put it to an appropriate position .

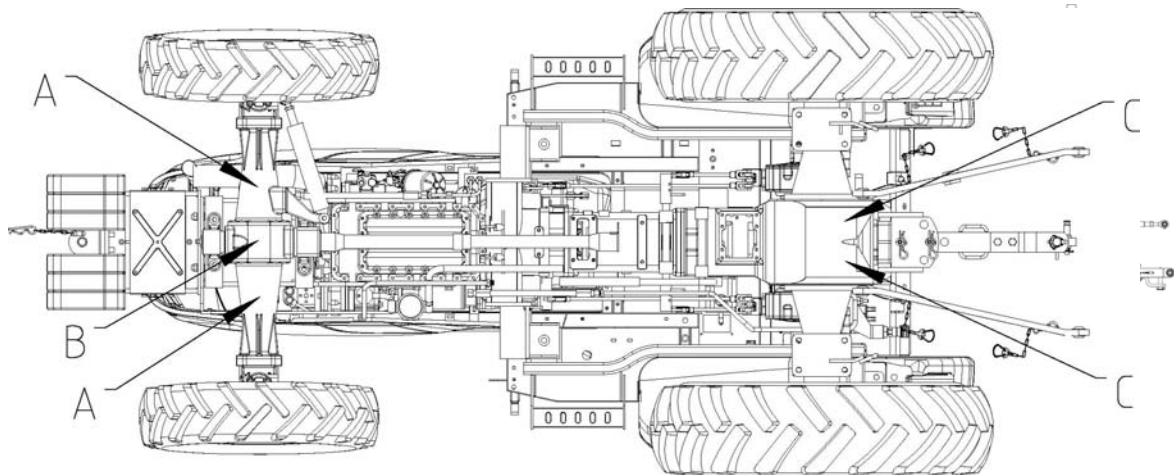
The carrying capacity of Crane must bigger than tractor technically permissible laden masses.



**Fig.4.18 Hosit tractor**

## 4.2.9 Jack tractor

Fig4.19 shows the recommended jacking points of tractor by a jack of sufficient lifiting capacity. The carrying capacity of Jack must bigger than tractor technically permissible laden masses.

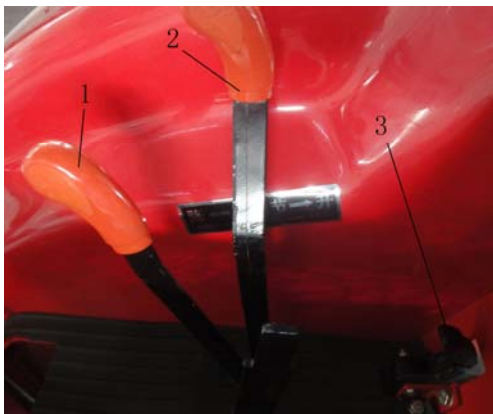


**Fig. 4-19**

- A——Front jacking point
- B——Middle jacking point of Axles
- C——Rear jacking point

## 4.3 Using the Tractor implents

### 4.3.1 Hydraulic lift system control lever



**Fig 4-20**

- 1、 Draft Control Lever
- 2、 Position Control Lever
- 3、 Rapid Lift Lever

#### 1、 Draft Control

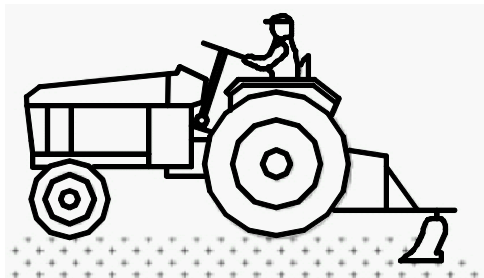
Use draft control lever to control the depth changes in a range, so keep the draft load constant automatically. This method is often applied when soil condition is almost the same.

See figure 4-21(a)

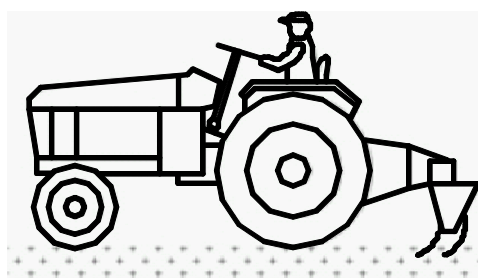
Move the position control lever all the way forward, then push the draft control lever forward at desired depth.

### 2. Position Control

Lift link should lift implements when doing spreader or sprayer. Draft load sensing does not work in this condition. You should adjust the depth with position control. See fig 4-21(b)

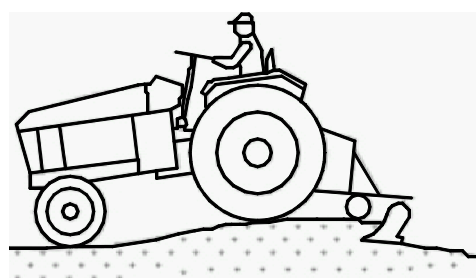


**Fig 4-21 (a)**



**Fig 4-21 (b)**

Push the draft control lever all the way down forward when using position control. Push the position lever forward to put down the implements and pull the position lever backward to lift the implements.



**Fig 4-21 (c)**

Operate in varying soil conditions. The implement is raised slightly automatically to get through tough spots so you do not have to shift to a lower gear.

### 3. Float Control

On uneven ground we need the implement float with the ground contour. See figure 4-21(c)

Push position control lever all the way forward and draft control knob all the way down forward so that implement can follow the ground contour.

NOTE: Lift links can be adjusted for implement float.

### 4. Draft and position control

Using draft and position control to control the depth applies operating in varied soil conditions. The implement is raised slightly to get through tough spots so you do not have to shift to a lower gear.

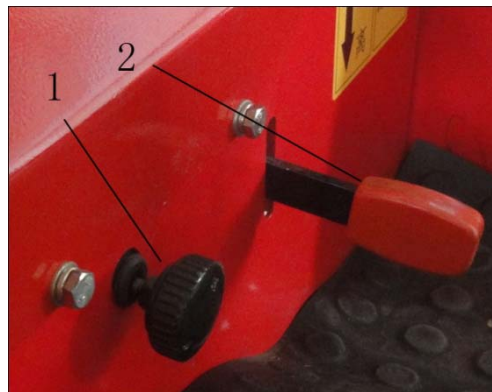
Push the position control lever all the way forward and the draft control lever backward. Push the draft control lever forward slowly with the tractor moving until the desired depth. Then pull the position control lever backward slightly until the lift arms tend to lift.

### 5. Rapid lift control

When the tractor turnaround in the end of the field or leaves the field or transport, the rapid lift lever can be used to lift the implement quickly (fig. 4-20). Using the rapid lift lever can lighten the burden of the driver.

Pull up the rapid lift lever to realize rapid lift. Keep it down when you don't need this function.

### 6. Control the drop speed of implement



**Fig 4-22 1、 Rate of Drop Knob 2、 Mid-PTO Lever**

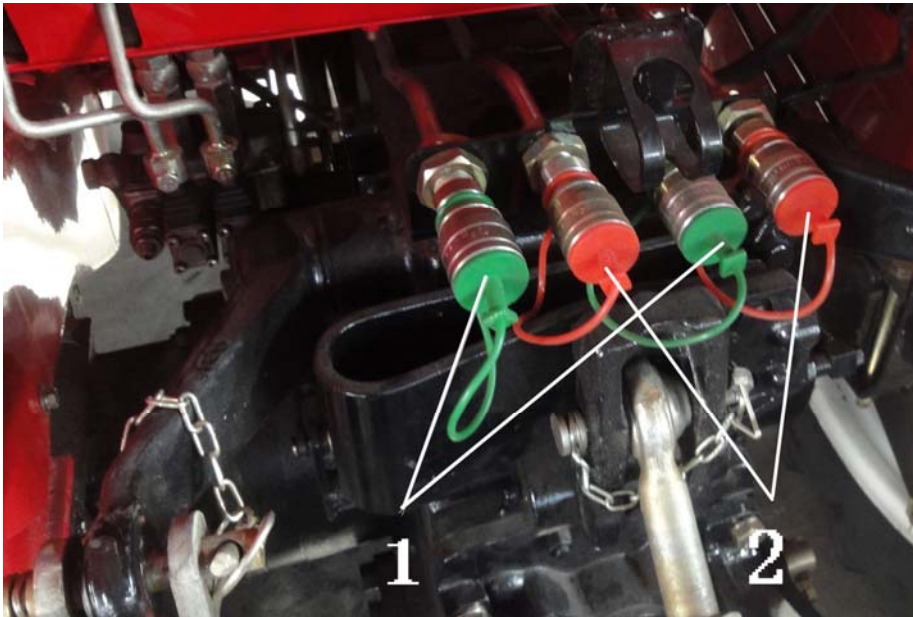
The rate of drop knob (fig. 4-22) can be used to control the drop speed of implement and set the implement at desired position. Choose the appropriate drop speed according to the weight of the implement and the soil condition to avoid too fast to damage the implement.

The rate of drop knob will control the speed valve directly. Turn the knob clockwise will slow down the speed and increase the speed otherwise.

Turn the knob until the implement could not be putted down when the tractor transport for a long distance (Be sure not turn the knob to the death). At this time, any control of position control lever or draft control lever or rapid lift lever is forbidden.



### 4.3.2 Use hydraulic output system



SCV Levers control oil flow to hydraulic hose couplers at the rear of the tractor.

SCV I Lever (Fig 4-1 NO.8) operates coupler (1).

SCV II Lever (Fig 4-1 NO.9) operates coupler (2).

Connect Hose:

- (1) Remove dust plugs from couplers.
- (2) Make sure that hose ends and coupler receptacles are clean and dry.
- (3) Coupler receive cylinder retract hose.
- (4) Coupler receive cylinder extend hose.
- (5) To connect each hose, push hose tip firmly into coupler receptacle. Pull lightly on hose to make sure that positive connection are made.
- (6) To make sure that hoses have been connected to correct receptacle, pull SCV I lever and SCV II lever slightly back of center. This should raise implement. If implement lowers instead of rising, hoses are reversed and need to be connected correctly.



**Fig 4-23**

Disconnect cylinder hoses

**IMPORTANT:** When disconnecting hoses, always grasp metal tip, never the hose itself.

Pulling on the hose instead of metal tip will eventually damage hose.

To disconnect hoses, grasp hose tip and give a firm pull.

### 4.3.3 Use 3-Point Hitch

- **Attach Implement to 3 point hitch**

1. Back tractor to implement so hitch point aligns.
2. Push hand throttle all the way forward and allow engine to idle for 1 to 2 min, then turn off engine.
3. Slip draft links over implement to hitch pins on both sides and retains with locking pins. When it is difficult to slip draft links over implement to hitch pins, operate as following step:
  - 1) Push down Plate (NO.1 in fig 4-24).
  - 2) Pull back adjust draft link (NO.2 in fig 4-24), and slip adjust draft links over implement to hitch pins on both sides and retains with locking pins.
  - 3) Adjust draft links to initial position and pull up Plate.



**Fig 4-24**

**1、 Plate**

**2、 Adjust Draft Link**

NOTE: Locking pins can be stored on draft links through holes in sway chain ears when not in use.

4. To remove upper link from transport hook,
5. Attach upper link to implement topmost, retain with pin and locking pin.
6. Adjust upper link and lift links as necessary. (See Leveling the Hitch in this section)

- **Adjust sway chains**

**IMPORTANT:** Do not shorten sway chains so short that do not allow hitch to be raised completely. If sway chains prevent hitch from rising, hydraulic relief valve opens, cause excessive oil heating and pump or equipment damage.

**NOTE:** Use spring or rubber strap to keep draft links clear of rear wheels when draft links are not attached to implements.

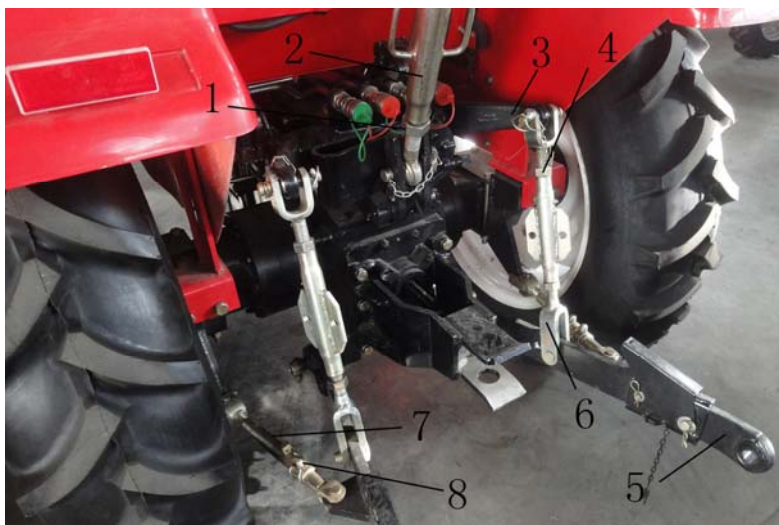
Check implement operator's manual for instructions whether to allow side sway. You can adjust the length of sway chains by loosening the jam nut (fig4-25) on sway chain strainer and turning the sway chain strainer to increase or decrease the length of chain. Tighten the jam nut again when adjusted.

- (1) When plough is attached to hitch system, side sway is needed and clearance of side sway is about 5cm.
- (2) When rotator is attached to hitch system, side sway should be clear by adjusting the length of sway chains.

- **Leveling the Hitch**

- (1) Lower implement to take weight off hitch.
- (2) Adjust upper link to level implement front to rear. Rotate the upper link body clockwise to lengthen upper link or counterclockwise to shorten it.
- (3) Adjust lift links to level implement side to side.

When plough with depth gauge wheels is attached to hitch system.



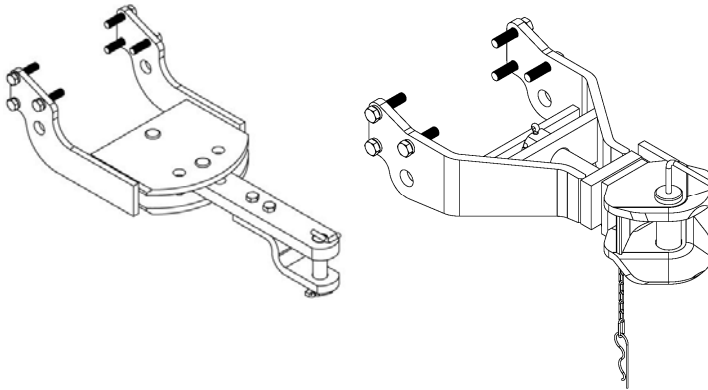
**Fig 4-25**

- 1、 Upper jam nut
- 2、 Upper link
- 3、 Lift arm
- 4、 Lift link jam nut
- 5、 Draft link
- 6、 Lift link
- 7、 Sway chain strainer
- 8、 Sway chain pin

### 4.3.4 Use Draw Bar

There are three type draw bar for attaching to the tractor.

- 1、 Disassemble the levers of 3 point hitch system; attach the draw bar (see fig 4-26) to the tractor. Then remove the pin from draw bar hole and attach trailer to draw bar.
- 2、 Rear ballast should be disassembled when signal shaft trailer is attach to draw bar.



**Fig 4-26**

### 4.3.5 PTO

Knegt series tractor PTO shaft adopts linkage type. It can use for move working and also fix working; Users can choose independent working PTO and non-independent working PTO . It's have hydraulic clutch when choosing the independent working PTO, and when the users choose non-independent working PTO ,the tractor don't have hydraulic clutch. When the tractor need the power take off with an implement, should do as following steps:

- (1) Switch off PTO switch so that PTO clutch is disengaged. Place the PTO lever in neutral position.
- (2) Disassemble the draw bar and twist off PTO cover. Then attach the implement to the 3 point hitch system. And link the implement and universal joint and PTO shaft.
- (3) Switch on PTO switch so that PTO clutch is engaged. Place the PTO lever in needed position, Check the operation situation in low speed. Then operate it in normal speed.

Move forward the operation handle, can get high gear 1000 r/min, if move backward, the low gear 540r/min will reach. When you don't need the power take off, the operation handle should be at neutral position, reinstall and fasten the telescopic outer of PTO

shaft.

These series tractors provide Rear PTO and Mid PTO which can drive mower. Speed of Mid PTO is 2000rpm. Rear PTO provides two type speeds as following:



**Fig 4-27**

- 1、 PTO Switch
- 2、 Electric hydraulic valve

### 4.3.6 Ballast

The tractor traction consisting of tractors power, and operation condition of the soil or road has been set, so the main factors affecting the traction force play is the tractor quality and the quality distribution of the front and rear wheels. The tractor must have a proper quality to play as soon as possible. The use of ballast should consider the load capacity of the tire and the maximum allowable quality of the tractor.



**Fig.4-28 Ballast**

The wrench should be used as a tool when load and unload ballasts.

When loading and unloading ballasts, it is necessary to pay attention to safety, ballasts easy to hit your feet. It is suggested that two people cooperate or find professional maintenance personnel when you need loading or unloading ballasts.

### 4.4 The use of electrical systems

The electrical system of each serie of tractor is dc power supply, the calibration voltage is 12V, the negative ground is grounded, the single line and double color system.

All kinds of electrical equipment adopt different wire diameters and different colored wires, which are connected according to certain rules and requirements, thus forming a complete machine circuit. See appendix 3 for the electrical schematic diagram.

#### 4.4.1 Generator and voltage regulator

The generator is the main power supply of the tractor, which is used to supply power to the electrical equipment and charge to the battery, and the voltage regulator is used to limit the generator to make the output voltage in the regulation value.

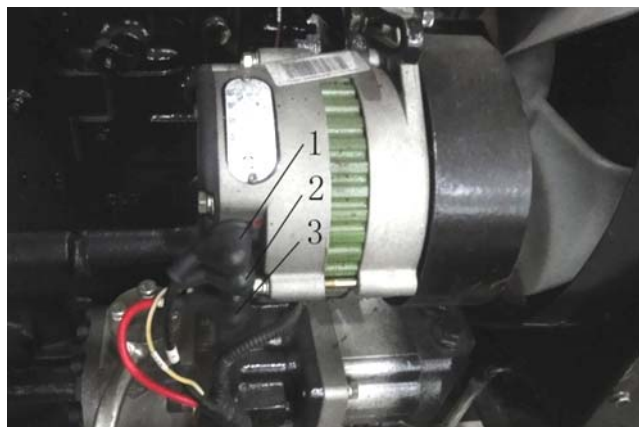
Attention should be paid to:

(1) It is not allowed to check whether the generator is generated by using B+ and ground fire; otherwise, the silicon rectifying element will be burned.

(2) When the engine is in operation, it is not allowed to remove the connection wires on the generator.

(3) The generator is negative grounded, and shall not be wrong, otherwise, the silicon rectifier element or regulator will be burnt.

(4) If the engine is running at a moderate speed, but the charging indicator will not be extinguished, indicating that the generator or regulator is out of order and the tractor should be stopped and checked immediately.



**Fig.4-29**

1.Cathode 2.Anode 3.B+

### 4.4.3 Start motor

Attention should be paid to:

- (1) Start motor and battery should be connected right and reliable.
- (2) The start motor shall not exceed 15s per working time, and the starting interval shall not be less than 2min. Otherwise, the capacity and performance of the battery will be seriously reduced, the start motor will overheat and reduce the service life, and even damage the start motor.
- (3) If three consecutive fails to start the tractor, the condition of electromagnetic switch, battery technology, the battery connection wire connection situation, as well as engine fuel supply system should be checked. Start the tractor again after solving the troubleshooting.
- (4) After the engine start, loosening the key of the power switch, otherwise, the power of the starting line fails to disconnect, the starting engine flywheel brought against after start motor, the start motor will be damaged.

### 4.4.4 Battery

These series of tractors provide you a free maintenance type of battery. Please do not open the battery shell. When battery shell burst by accident, please don't dispose it at will, because of sulfuric acid in the electrolyte of the battery is toxic, it is easy to burn the skin, corrosion and so on. you should wear protective glasses and rubber gloves at the same time, use dry cloth to wipe dry sulfuric acid, with plenty of water and clean the residual sulfuric acid. If you accidentally splash the electrolyte into your face or eyes, wipe clean with dry cleaning cloth immediately, rinse with plenty of water, and seek medical attention immediately when serious.

Attention should be paid to:

- (1) Do not discharge the battery strongly in a long time, otherwise the battery will be damaged.
- (2) Pay regular attention to the battery power, which must be charged in time.
- (3) In normal use, if the battery is found to be undercharged, the working conditions of the generator and regulator must be checked and the battery shall be recharged.
- (4) It is strictly forbidden to put the battery on hold for a long time after it is discharged, and it should be recharged in time. A battery that hasn't been recharged for long periods of time will be recharged at least once a month to prevent the plate vulcanisation.

## 504G3 SERIES TRACTOR OPERATION MANUAL

(5) If the tractor is parked in the open air for a long time in winter, the battery should be taken down and placed in a room with temperature of more than 0°C.

(6) In order to avoid oxidation of pole pile and lead head, it is necessary to keep pole pile and lead head clean frequently. If there is an oxide, use a knife to clean, and apply a layer of petroleum jelly or calcium base grease.

### 4.4.5 Insurance device

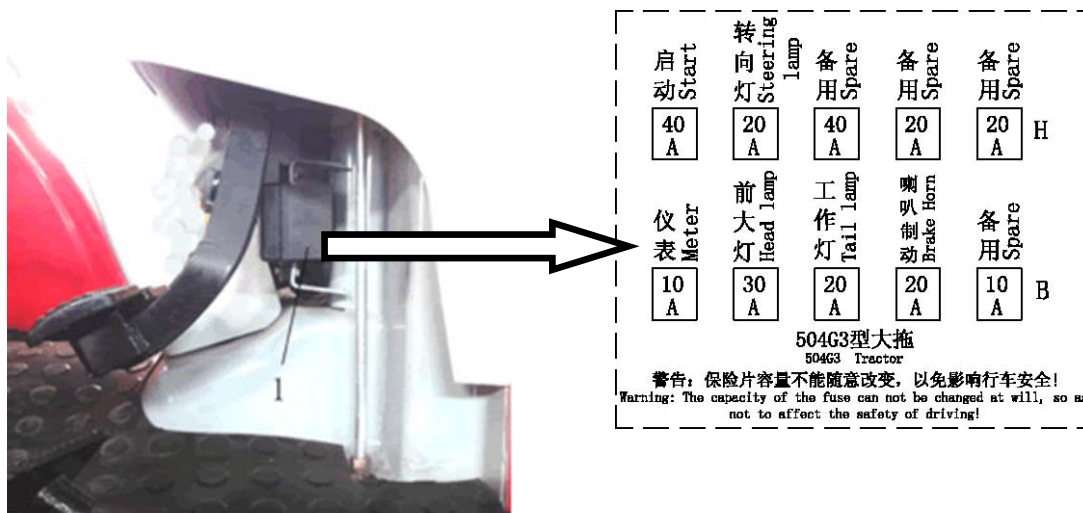
The tractor instrument rack is equipped with a fuse box, which can be used to protect different electrical components according to the different load of electric equipment.(see fig 4-)

#### WARNING:

(1)If there is a fault in the electrical components, check whether the fuse in the corresponding position of the line is burn out. If it has been broken, you can take a period of fuse from the fuses, tightly fix it between two clamps, then plug the fuse back in place.

(2)If the installed fuses are defined but the fuse is often burned, which indicating that there may be a line faults should be checked and excluded. It is not allowed to use multiple units or increase the capacity of the fuse instead, or it will burn the electrical components in the circuit.

(3) It is strictly forbidden to use copper wire or iron wire to replace the fuse, otherwise it



**Fig.4-30**

would lose the insurance function, and damage the electrical components in the circuit.



## Chapter 5 Maintenance

Maintain the tractor well can make it work in a good condition, and protect the tractor from damage, even extend the life.

**⚠CAUTION: Maintenance must be operated when the tractor is out of power!**

### 5.1 Oil and lubricants

#### 1、 Oil and lubricants

Position	Temperature range	Category of oil	Remark
Fuel tank	Above 10° C	No. 0 light diesel	GB252-87
	0° ~10° C	No. -10 light diesel	
	Below -10° C	No. -35 light diesel	
Gearbox, front drive axle, hydraulic system, and steering system	All atmospheric temperature	N100 D transmission drive & hydraulic dual-purpose oil	GB443-84
Grease fittings	All atmospheric temperature	No. 2 and No. 3 calcic lubricant	GB491-87
Engine sump	Summer	No.40 diesel engine oil	GB5323-85
	Winter	No.30 diesel engine oil	
Clutch release bearing	All atmospheric temperature	Lithium lubricant	GB5671-85

#### 2、 Position

Oil inlet      ①engine,      ②right place of rear axle housing,  
                   ③air pump crankcase,      ④left sleeve of front drive axle,  
                   ⑤oil case of steering system.

Grease fittings      ①Left and right lift arms,      ②center link,  
                           ③steering cylinder shaft with pin holes      ④outer tie rod joints  
                           ⑤steering levers and steering arms

- ⑥front axle arms      ⑦left and right front wheel housings

Checking point ①Engine dipstick ②Rear axle housing dipstick,

③Dipstick on left half shaft housing of front wheel drive axle

④Checking plug on the cover of air pump

Oil outlet, ①Bottom of engine sump, ②bottom of rear axle,

④bottom of air pump; ⑤bottom of front drive center housing, and  
bootom of left and right retarder housing.

### 5.2 Periodic Service

According to accumulated working hours, technical maintenance of Knegt series tractor should be operated every 10h, 50h, 200h, 400h, 800h or 1600h.

Details of the engine's maintenance can be refered in the manual of engine.

#### 5.2.1 10h maintenance

##### 1、 Engine

① Check the liquid level of engine sump, refill them if they are insufficient, and make sure the level will be between the middle notch and the topper notch on the dipstick. Never exceed the topper notch. A new tractor or one haven't used for a long time, the level must be checked again after filling and operating for 5 to 10 minutes.

② Fill in enough diesel oil and cooling water.

##### 2、 Chassis

① Check and fasten every external linkage bolts and nuts.

② Use a press rod oil gun at these places: left and right retarder housing.

③ Check and eleminate if there is a leakage of oil, water or air. Clean off the dirt and mud on the tractor.

④ Check the air pressure of front and rear tires, and inflate if they are insufficient.

##### 3、 Air Conditioning Systems

① Check cleaning condenser, and insure the radiating fins clean and expedite.

② Check the drive belt of compressor and engine, and insure it's not loose.

### 5.2.2 50h maintenance

1. Engine: After 50 hours of light load working, the oil in the engine sump and injection pump should be changed, at the same time, change the filter element; clean the sump, the filter and the filter net with clean diesel.
2. Transmission system: After using for 50 hours, it will be needed to check the free travel of the clutch pedal, and adjust it if necessary.
3. Accumulator: Check the accumulator of it's electrical power, charge it if it is not sufficient.
4. Use a press rod oil gun at these places: Left and right draft links, center link, tie rod joints, steering cylinder shaft with pin hole.
5. Air Conditioning System: Check the connecting parts and hose, repair or fix the parts when they are loose; check all the electrical connectors and wires, examine and repair them if they are deviant.

### 5.2.3 100h maintenance

1. Engine
  - ① Change the oil in the sump, clean the filter strainer.
  - ② Change engine oil and diesel filter elements, and clean the cavity of filter.
  - ③ Check the tension of fan belt, adjust it if loosed.
  - ④ Check the level of injection pump, refill it if needed.
  - ⑤ Clean the air filter and replace oil (Necessary to perform every time after working in wet and muddy conditions).
2. Clutch: Check the free travel, adjust it if necessary.

### 5.2.4 250h maintenance

1. Transmission ssystem: Check the oil level of chassis, refill it if needed.
2. Front axle: Check the toe-in and the bearings of front axle (Two wheel drive), adjust them is needed.
3. Accumulator: Smear Vaseline or calcic lubricant on the bolts of accumulator.

### 5.2.5 500h maintenance

1. Check the pressure and fogging quality of the engine oil pump, clean it if necessary.

2. Check and fasten the nuts of engine cylinder head, adjust the valve clearance if needed.
3. Clean the water scale in the cooling system.
4. Replace the oil of the injection pump.

### 5.2.6 1000h maintenance

1. Engine
  - ① Check the condition of the valve, repair it if necessary.
  - ② Check the advance angle of injection, make adjustment if necessary.
2. Transmission system: Change the lubricant one time a year at least.
3. Steering system: Check the lubrication of the steering cylinder, refill if it's not sufficient.
4. Check the electrical circuit completely, replaces all of the broken parts.

#### **NOTE:**

- (1) Operate these maintenance according to the schedule will help your tractor work normally.
- (2) The service interval is determined according to the condition of working and your experience.
- (3) Remember that, in any case, it is better to check too much than too little.
- (4) If you have any problem during the maintenance, contact your dealer or the after service.
- (5) Air Conditioning System: Refrigerant in air conditioning system will leak naturally, supply the refrigerant according to the leakage flux.

## 5.3 Transporting the Machine

### 5.3.1 Preparing for Road travel

Before transporting the machine, make sure you will be obeying all local rules and laws of the areas through which the machine will transported.

Confirm that the truck driver knows the clearance height before he drives away. See Specification Section for machine height figures.

The overall height does not include the truck/trailer height, add the two figures together

for the clearance height.

### 5.3.2 Before Using the Trailer/Transporter

1. Remove any dirt or debris from the trailer.
2. Check the operation of the park brake.
3. Check the trailer bodywork for signs of damage.
4. Check the tyre pressures are correct.
5. Check the lights are working and are the correct voltage for the towing vehicle.
6. Check the breakaway cable is serviceable

### 5.3.3 Loading a Machine onto the Transporting Vehicle

The safe transit of the load is the responsibility of the transport contractor and driver. Any machine, attachments or parts that may move during transit must be adequately secured.

Before moving the machine onto the trailer, make sure that the trailer and ramp are free from oil, grease and ice. Remove oil, grease and ice from the machine tyres. Make sure the machine will not foul on the ramp angle. See Static Dimensions in **SPECIFICATION** section for the minimum ground clearance of your machine.

The ramp should be long enough that the angles between the truck or trailer do not cause the machine components to catch when moving from ramp to truck or trailer. If loading on or near a slope, position the truck or trailer on the down side of the slope and the ramps should extend up the slope. This will minimize the ramp angle. The trailer or truck should be parked as level as possible to facilitate smooth loading of the machine.

Avoid sudden acceleration and deceleration of the unit when loading and unloading the unit to avoid the machine tipping backward.

Also we can use crane or other equipment to hoist tractor from earth to trailer.

### 5.3.4 Transporting the Machine

Use a heavy duty trailer or truck to transport the machine. Make sure the trailer or truck has all of the necessary lighting and markings as required by law.

When transporting the machine, make sure the three point linkage is raised, the park brake is applied, the wheels have been blocked, the machine has been securely fastened by cables, chains or ropes, and the trailer has been secured to the towing vehicle with safety chains.

Driving on a public street or roadway without turn signals, slow moving vehicle emblem, or reflective markings could lead to accidents causing serious personal injury or death.

**⚠️Note:** Keep the tractor in a dry place where the tractor is sheltered from the elements. Cover the tractor.

**⚠️Note:** If you want to use tractor after transporting, you must see **4.2.3 Operating the Engine.**

### 5.4 Storage

The tractor must be well stored after working or when it will not be used for a long time, so it can be protect from corrosion and deterioration.

#### 5.4.1 Preparation for Storage

1. According to the manual of engine to store and maintain the diesel engine.
2. Thoroughly clean the tractor, especially the body parts, brush protective coating on the painted metal parts, store the tractor under cover and in dry and well-ventilated places.
3. Brush anti-rust paint on the unpainted metal parts.
4. Ensure that all controls are in neutral or off position (including the electrical switch and the parking brake).
5. Do not leave the key in the electric switch.
6. Fill the fuel tank to the topper level.
7. Remove battery, clean battery top and coat terminal clamps and leads with Vaseline or calcic lubricant, subsequently store the battery in dim and ventilated places with temperature remaining above 0°C.
8. Put stands or other supports under the front axle/front wheel drive axle and rear axle in order to bear the tractor weight. With the tractor being propped up, it is advisable to deflate tires.
9. Drain away thoroughly the water in radiator for passing away in the winter season.
10. Cover the tractor with waterproof canvas to prevent from dust or water.


Refer to the manual of engine for the storage of engine.

### 5.4.2 Tractor maintenance during storage

1. During the storage, check and protect the tractor from rust, corrosion, deterioration and deformation every month.
2. Start the tractor every 3 month, and run it at a low speed for 20 to 30 minutes, check if there is somewhere abnormal. Before start the engine, follow the request to add in coolant, diesel, oil and lubricant.
3. Check the condition of the accumulator. It's better to charge the battery every month for it will discharge when not be used.

### 5.4.3 Preparation after Storage

1. Remove the waterproof canvas, clean the tractor.
2. According to the request to fill with coolant, diesel, oil and lubricant.
3. Check the tire pressure and charge if it is not sufficient.
4. Check and charge the accumulator.
5. Check and tighten every external bolts and nuts, especially the bolts on the rear wheel hub, flywheel housing and clutch housing and so on. Check the condition of the pipeline and electrical facility, clear the problem if find.
6. Operate the tractor as chapter 4 required, if there is any problem, clear it immediately.

** Important:** Refer to manual of engine to get information about the engine's moving from storage.

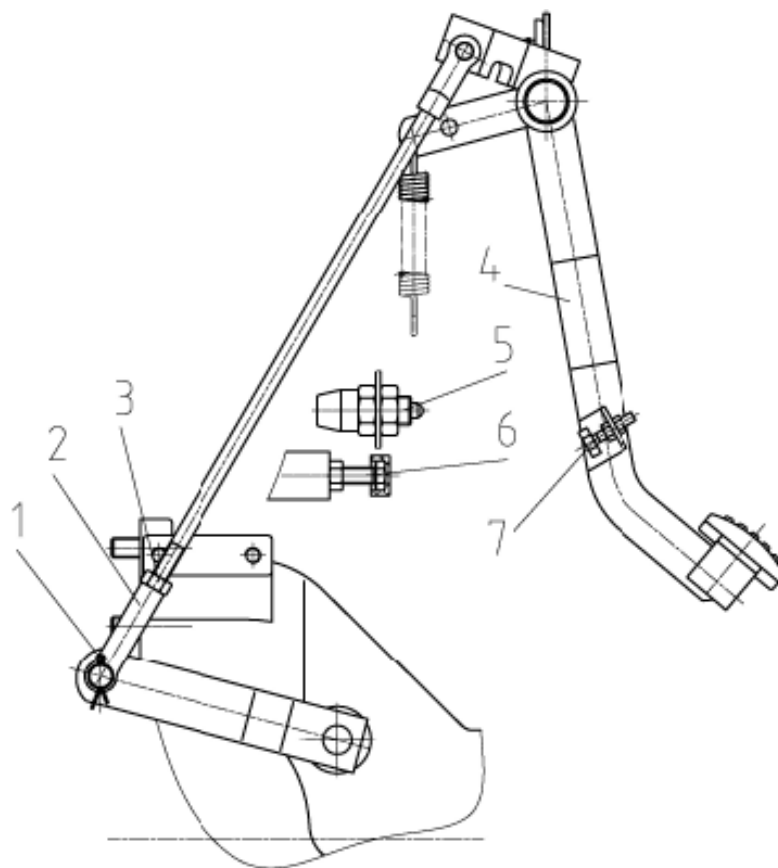
## Chapter 6 Adjustment of the tractor

### 6.1 Adjustment of the engine

Details of the engine Adjustment can be approached in the manual of engine

### 6.2 Adjustment of the clutch

Because of abrading, the clearance between the release lever's head and the release bearing become small and small, even make the lever and the bearing connect and rotating together. As a result, the clutch can't work efficiently any more. So it should be check and adjust regularly.



**Fig.6-1**

1. Split pin
2. Pull rod head part
3. Adjusting nut
4. Clutch pedal
5. Protection switch
6. Limit bolt
7. Bolt

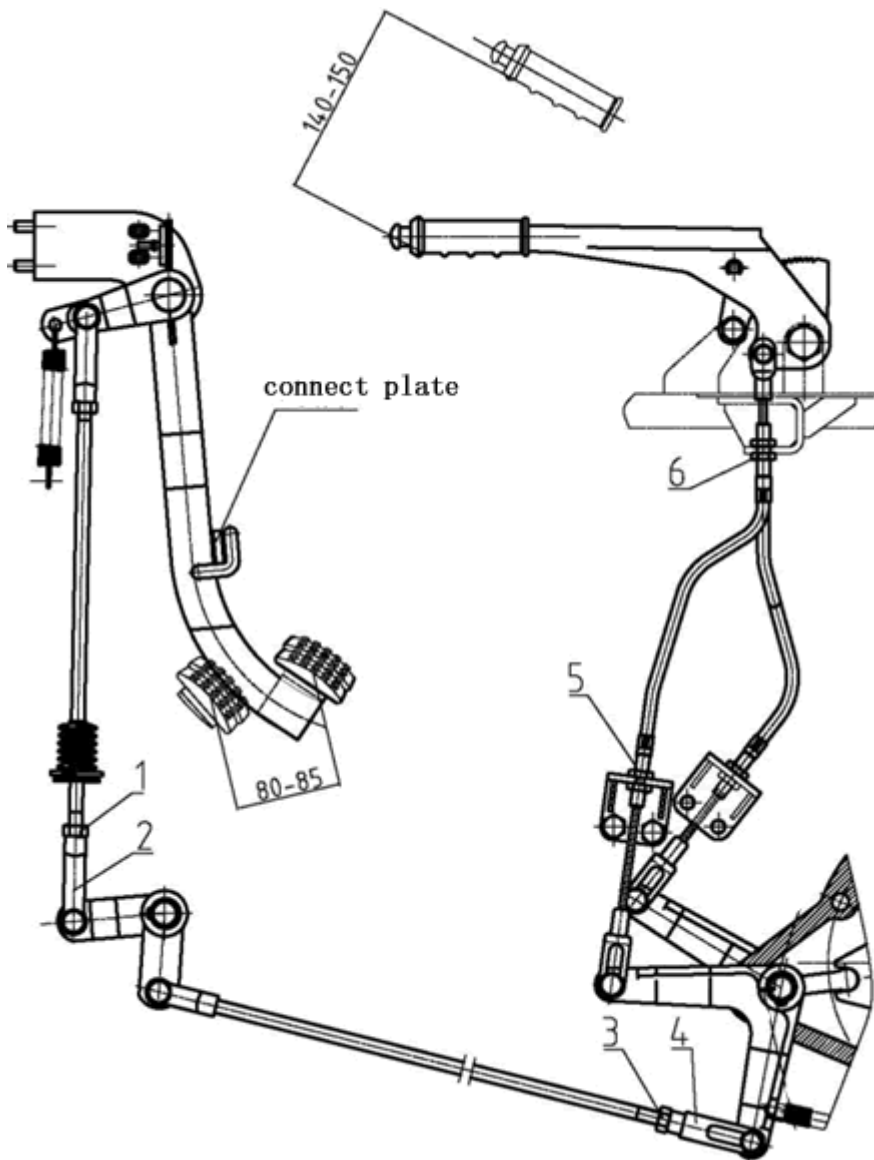
As Fig.6-1 shows, when assembling the clutch, make sure the clearance between release bearing and release rod be  $2.5 \pm 0.5$ mm, namely the clutch pedal free path should be about 30mm.

When adjusting, at first, remove the split pin 1, pull out the shaft and washer, at the



same time, screw the adjusting nut 3, adjust the pull rod head part 2 to insure the pedal free path be in the stated range, then tighten the adjusting nut 3, make the hole of the pull rod head part right at the proper place, at last, mount the shaft, washer and the split pin..

### 6.3 Adjustment of the Brake



**Fig 6-2**

- |                    |                         |                    |                         |
|--------------------|-------------------------|--------------------|-------------------------|
| 1. Adjusting nut A | 2. Pull rod head part A | 3. Adjusting nut B | 4. Pull rod head part B |
| 5. Adjusting nut C | 6. Adjusting nut D      |                    |                         |

The free path of the brake pedal is between 80 and 85mm. During the usage, as the driven disk abrading, the free path exceeds the regular range, even influence braking, so it must be adjusted.

### **6.3.1 Adjustment of service braking system**

Before regulating, disconnect the connect plate, and adjust the free path of every pedal. As Fig.6-2 shows, adjust piece 1 and 2 or (with) piece 3 and 4. Here gives the way of how to adjust piece 1 and 2 as follows.

At first, bring down the split pin and shaft, then screw the nut 1, rotating the pull rod head part A to regulate the length of the pull rod, so make the free path of every pedal be about the same and between 80 and 85mm, after that, fasten the nut.

After adjusting the pedal, the tractor must be test at the highest speed on the dry flat, and then try to brake urgently. After that, check the tire print lengths. Make sure the diffence between left one and right one doesn't exceed 400mm. If it fails to reach the request, adjust again.

### **6.3.2 Adjustment of parking braking system**

Before regulating, bring down the split pin and shaft,then screw the nut 5 or 6,making the clevis of flexible line fit with the brake rocker hole, and then fasten the nuts.

After adjusting the flexible line,the tractor must immovable on the ramp when using the parking braking system.If the tractor have a remotion,it's must be adjusted again

## **6.4 Adjustment of the Chassis**

In order to ensure the reliable of the main drive, the spiral bevel pinion and the spiral crown gear should be a matched pair when assembling, at the same time, they should be adjusted correctly to approach the right meshing zone. The position must be adjusted when the gears or the bearings are abraded.

### **6.4.1 Adjustment of the pre-stress of the spiral bevel pinion bearings**

The two bearings 2 and 5 on the shaft should be pre-stressed (Fig.6-3). The pressure is adjusted by screw the locking nut 1. It has been adjusted to the proper pressure by the factory, and will not be adjusted again only when the bearings 2 and 5 should be

changed or this part needs a repair. When adjusting, screw down the bolts 3 (totally 4), get down the assemblage of spiral bevel pinion, then clamp the assemblage to a table vice or other work platform. Loose the locking nut 1, and then knock the spiral bevel pinion and the bearings down. Change the bearings and locking nut. Make sure there is a torque of 1.5 to 2.5Nm when rotating the pinion. If no equipment or tool can be used to measure the torque, ask somebody who is experienced for help. At last, lock the locking nut.

### **6.4.2 Adjustment of the spiral bevel pinion and spiral bevel crown gear**

Correct meshing zone and right clearance between tooth of the drive pinion and crown gear can influence the life of the main drive and the noise (Fig.6-3). Because of abrasion of the gears and bearings, the clearance increases. As a result, the gears can not work in the correct meshing zone. There is no necessary to adjust only when it effect the gears to work normally or the bearings and the bevel gears need to be replaced or the assemblage needs to be repaired. (The adjusting needs to be done after the bearings have been fastened.)

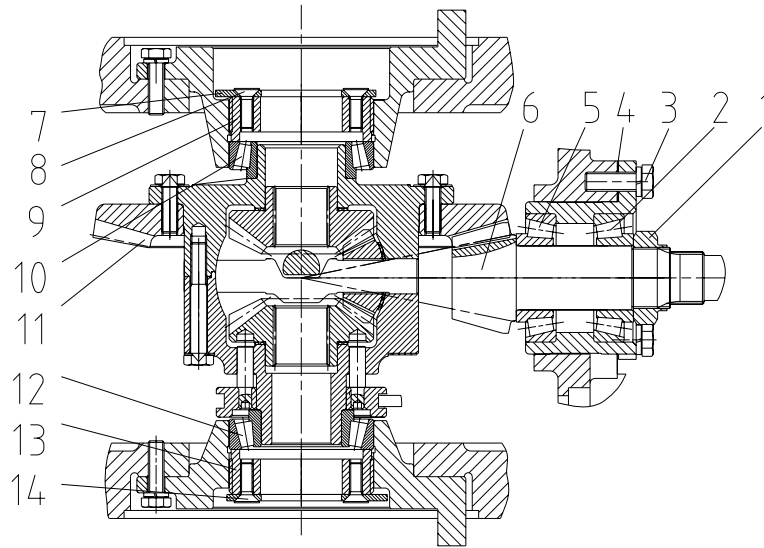
#### 1. Check the clearance between the teeth

Make sure the clearance of the pinion and crown gears at the stated range. Only when the clearance is large enough, it should be adjusted.

When adjusting, put a lead piece between the teeth of pinion and crown gears. The lead piece will be pushed to transform. Then measure the thickness of lead piece near the big end. The proper clearance changes from 0.16 to 0.32mm. Measure it for 3 times and at 3 point which equally at the circle. The difference between them should be less than 0.1mm. If it failed to reach the request, adjust the adjusting nuts (9) and (13).

#### 2. Checking the meshing zone

Through measuring the meshing zone, we can know if the gears work normally. The meshing zone can be measured by smear test , painting the crown gear teeth with some colors such as red lead or Prussian blue. The standard meshing zone should be in the middle of all the teeth face and deflecting to small end of teeth slightly. It's length at least equal to 55% of the width, and its height equal to at least 55% of the tooth's height. If the meshing zone doesn't accord with the proper position, the bevel gears should be adjusted.



**Fig.6-3**

- |                               |                          |                                    |                          |                   |
|-------------------------------|--------------------------|------------------------------------|--------------------------|-------------------|
| <b>1. Locking nut</b>         | <b>2. Bearing</b>        | <b>3. Bolt</b>                     | <b>4. Adjusting shim</b> | <b>5. Bearing</b> |
| <b>6. Spiral bevel pinion</b> | <b>7. Locking board</b>  | <b>8. Cross head screw</b>         |                          |                   |
| <b>9. Adjusting nut</b>       | <b>10. Bearing</b>       | <b>11. Spiral bevel crown gear</b> |                          |                   |
| <b>12. Bearing</b>            | <b>13. Adjusting nut</b> | <b>14. Cross head screw</b>        |                          |                   |

Through changing the thickness of the adjusting shim to move the spiral bevel pinion along the axle direction, and it can also move the Spiral bevel crown gear by adjusting the nuts (9) and (13). Both of the two methods can help to adjust.

During the adjustment, when it has the proper meshing zone, but without the correct clearance, or on the other way, it should be better to get the proper meshing zone, with the clearance not less than 0.16mm.

## 6.5 Adjustment of the Front Axle (4WD)

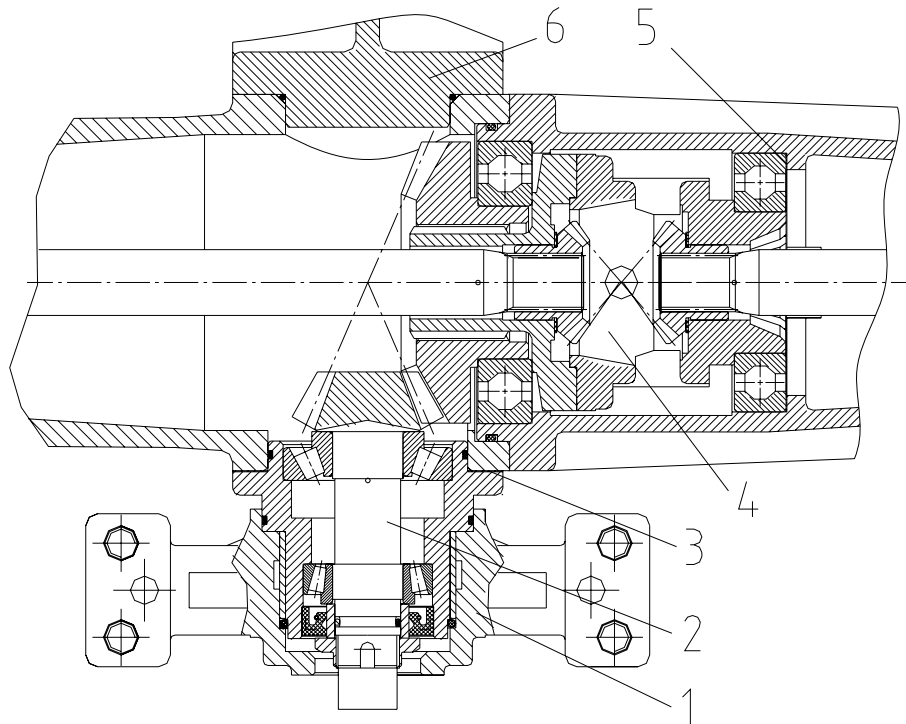
To insure the reliability of the front axle bevel transmission, assembled pinion and crown gears should be a pair of match. And they should get to the proper mashing zone. During the usage, the gears must be adjusted when the bearings and gears abraded (Fig.6-4).

### 6.5.1 Adjustment of the pre-stress of the spiral bevel pinion bearings

The adjustment of this part is similar to the description 6.4.1, just insure the torque when rotating the pinion gear get to 1.2~1.5Nm. Somebody who is experienced should be asked for help when there is no equipment or tool can be used to measure the

torque.

## 6.5.2 Adjustment of the spiral bevel pinion and spiral bevel crown gear



**Fig.6-4**

- |                          |   |
|--------------------------|---|
| <b>1. Back seat</b>      | <b>2. Assemblage of the spiral bevel pinion</b> |
| <b>3. Adjusting shim</b> | <b>4. Assemblage of the differential</b>        |
| <b>5. Adjusting shim</b> | <b>6. Front seat</b>                            |

Because of abrasion of the gears and bearings, the clearance increases. As a result, the gears can not work in the correct meshing zone. There is no necessary to adjust only when it effect the gears to work normally or the bearings and the bevel gears need to be replaced or the assemblage needs to be repaired. (The adjusting needs to be done after the bearings have been fastened.)

### 1. Checking the clearance between the teeth

Make sure the clearance of the pinion and crown gears at the stated-range. Only when the clearance is large enough, it should be adjusted.

When adjusting, bring down the back seat (1) and (6), put a lead piece between the teeth of pinion and crown gears. The lead piece will be pushed to transform. Then measure the thickness of lead piece near the big end. The proper clearance changes from 0.16 to

0.32mm. Measure it for 3 times and at 3 point which equally at the circle. The difference between them should be less than 0.1mm. If it failed to reach the request, adjust the thickness of adjusting shim (5). At last, put all of the components on.

### 2. Checking the meshing zone

The meshing zone can be measured by smear test, painting the crown gear teeth with some colors such as red lead or Prussian blue. The standard meshing zone should be in the middle of all the teeth face and deflecting to small end of teeth slightly. It's length at least equal to 55% of the width, and it's height equal to at least 55% of the tooth's height. If the meshing zone doesn't accord with the proper position, adjust the thickness of the shim (3) and (5).

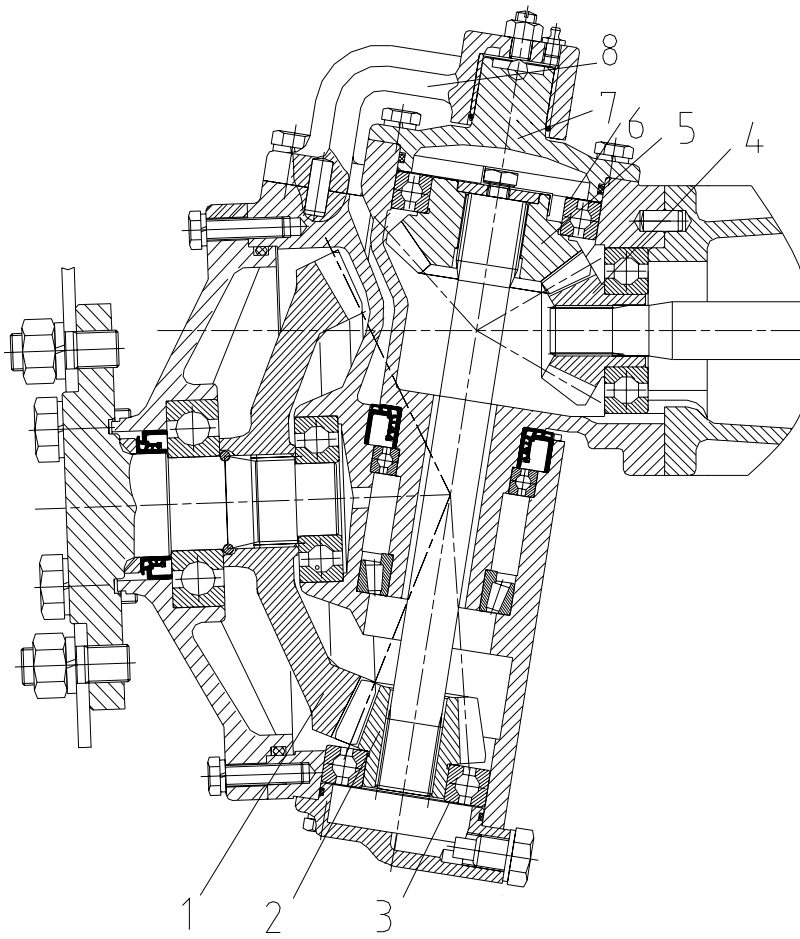
During the adjustment, when it has the proper meshing zone, but without the correct clearance, or on the other way, it should be better to get the proper meshing zone, with the clearance not less than 0.2mm.

### 6.5.3 Adjustment of front axle final transmission

There are two couples of gears in the front axle final transmission (As Fig.6-5 shows, one couple is piece 1, 2 and another is piece 4, 5). They have been adjusted in the factory, generally, there is no need to adjust them by the users unless replacing the bearings and gears or do some repairs. The two couples have the same way to be adjust, here will give the example.

Before adjusting, bring down the tire, raise the front axle. Remove the steering arm (8) and upper bearing cover (7), adjust the clearance between drive pinion (4) and drive pinion (5) through changing the thickness of adjusting shim (6).

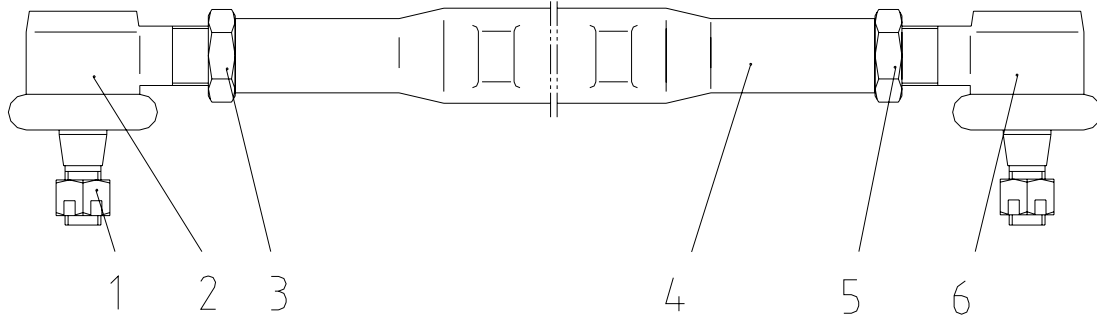
Generally, the clearance is between 0.16 to 0.3mm. After the adjustment, reinstall all of the components. It's better to ask someone professional to finish the work.



**Fig.6-5**

- |                                       |                                      |                         |
|---------------------------------------|--------------------------------------|-------------------------|
| <b>1. Final reduction driven gear</b> | <b>2. Final reduction drive gear</b> |                         |
| <b>3. Adjusting shim</b>              | <b>4. Drive pinion</b>               | <b>5. Driven pinion</b> |
| <b>6. Adjusting shim</b>              | <b>7. Upper bearing cover</b>        | <b>8. Steering arm</b>  |

## 6.6 Adjustment of the toe-in



**Fig. 6-8**

- |                             |                             |                            |
|-----------------------------|-----------------------------|----------------------------|
| <b>1. Nut</b>               | <b>2. Pull rod tie-in</b>   | <b>3. Left-helical nut</b> |
| <b>4. Assistant tie rod</b> | <b>5. Right-helical nut</b> | <b>6. Pull rod tie-in</b>  |

After working for 500 hours, or the front wheels sways obviously, or the tire of front wheels abraded quickly, the tie-in needs to be checked. The proper tie-in is between 4 and 8 mm, it must be adjusted as well as it exceeds the range (Fig.6-8). When adjusting, put the tractor on the flat place, at the same time; turn the steering wheel to the mid position to make the wheels straight. Then loosen the left & right helical nut (3) and (5), rotate assistant tie rod (4). Measure the front and rear distances between two steering wheels at the same height of the front wheels shaft through the center of steering wheels. Adjust the assistant tie rod till the front distance is around 4 ~ 8 mm less than the rear distance ( $B_{\text{rear}} - B_{\text{front}} = 4 \sim 8 \text{ mm}$ ). Tighten both of the nuts at last.

**▲ Attention: After adjusting, the left and right adjusting nut (3) and (5) must be screw down!**

## 6.7 Adjustment of the wheel track

The front wheel track of the 4WD front axle can be different by changing the way of assembling the left and right wheels. One of the wheel tracks is 1251mm, and the other one is 1295mm. Wheel track of 1295mm would be the normal when assembling in the factory.

Changing the spoke's assembling position to the wheel rim, the rear wheel track can be 1161mm, 1261mm, 1361mm and 1461mm. Wheel track of 1261mm would be the



normal when assembling in the factory. Users can adjust the wheel track according to their needs.

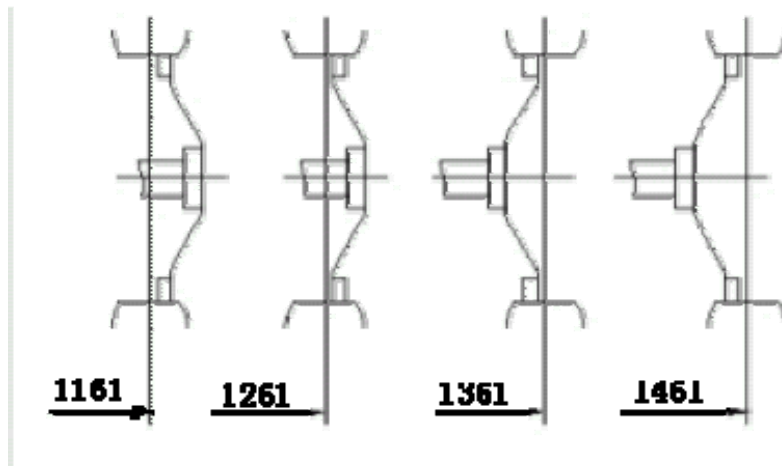
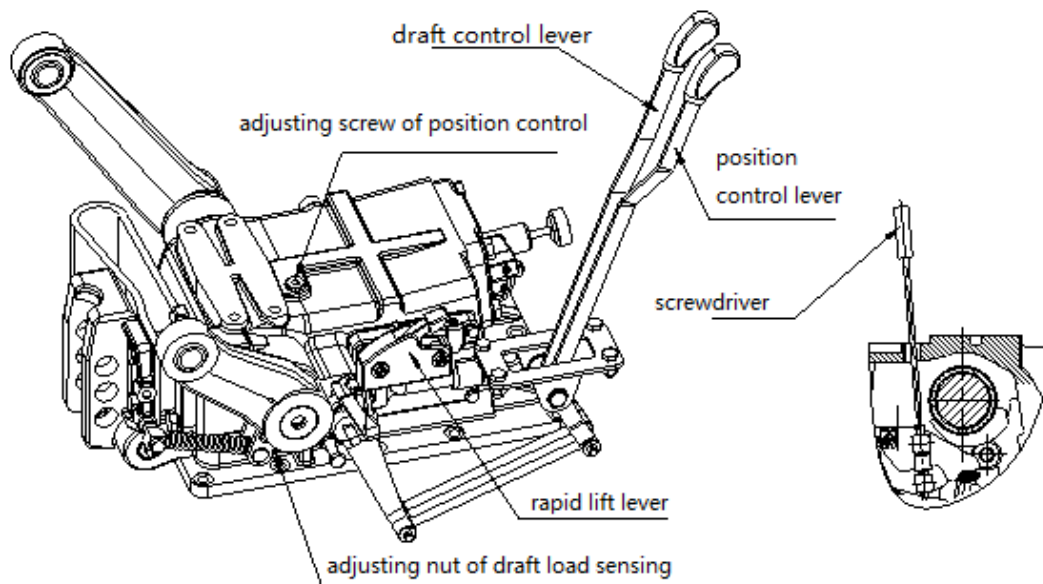


Fig.6-9

## 6.8 Adjustment of rockshaft system

### ① Adjustment of position control

Check the lift height of the rockshaft after a period of time. It should be adjusted if it is



not sufficient. Open the plug on the top of the housing, use a screwdriver and turn clockwise slightly. Then lift the lift arms to the tiptop position and pull up the rapid lift lever. Check whether it can be lifted 1-3 degrees. If there is no allowance then adjust it at the opposite direction until reach 1-3 degree.

### ② Adjustment of draft control

Unpack the implement and push the position control lever to the end as well as the draft control lever. Put down the lift links to the ground. Pull the draft control lever until the lift arms tend to lift. Now the position of the draft control lever should be 5 to 10 degrees to the back end. If it's bigger the 10 degrees, tighten the adjust nut of draft load sensing slightly.

**NOTE:** if the degree is more than  $10^{\circ}$  , the draft control lever cannot be pushed to the maximum position or the desired depth cannot be achieve when use both draft control lever and position control lever.

## Chapter 7 Troubleshooting

Abration, deformation and improper servicing contribute to a technical change of the components. Then it will cause troubles. At this time, the tractor must be checked and get rid of them. If failed to do this, the conditions may be worse, even result in an accident.

This chapter stress on the troubleshooting of chassis and electrical system. Details about the engine troubleshooting will be showed in the operator's manual of engine.

### 7.1 Clutch

<b>Troubles &amp; possible causes</b>	<b>Fixing methods</b>
<p><b>(1) Clutch slip</b></p> <ul style="list-style-type: none"> <li>① The clutch disk or clutch plate is stained with oil.</li> <li>② Abrasion to clutch disk is uneven or the abrasion is serious.</li> <li>③ The free path is not enough or no free path.</li> <li>④ The driven disk is deformed.</li> </ul>	<ul style="list-style-type: none"> <li>① Wash them clean with gasoline, and eliminate the oil leakage</li> <li>② Replace the clutch disk</li> <li>③ Readjust in accordance with the requirement</li> <li>④ Replace the driven disk</li> </ul>
<p><b>(2) Clutch cannot be separated completely</b></p> <ul style="list-style-type: none"> <li>① The pedal's free path is too large, and the working path is too small.</li> <li>② The driven disk warps too much.</li> <li>③ The release finger of diaphragm spring are not at the same plane</li> </ul>	<ul style="list-style-type: none"> <li>① Adjust the pedal free travel as specified</li> <li>② Rectify or replace with a new one</li> <li>③ Replace</li> </ul>
<p><b>(3) The tractor is shivering at starting</b></p> <ul style="list-style-type: none"> <li>① The friction disk and the driven disk are stained with oil</li> <li>② The friction disk broke up</li> <li>③ The driven disk warps</li> </ul>	<ul style="list-style-type: none"> <li>① Clean friction disk and driven disk</li> <li>② Replace</li> <li>③ Replace</li> </ul>
<p><b>(4) There is vibration and noise in the clutch</b></p> <ul style="list-style-type: none"> <li>① Releasing bearing is lacking of oil or broken</li> <li>② The spline of driven disk or the clutch has been weared out</li> </ul>	<ul style="list-style-type: none"> <li>① Oiling or replacing</li> <li>② Replacing</li> </ul>

## 7.2 Gearbox

<b>Troubles &amp; possible causes</b>	<b>Fixing methods</b>
<b>(1) There are hum or slap noises in the gearbox</b> ① The gear abraded heavily, or the tooth face peels off, or the gear teeth are broke ② Bearing abraded seriously or damaged ③ Improper clearance of bevel transmission ④ Lubricating oil is not enough or does not conform to the requirement	① Replace gear ② Replace bearing ③ Adjust ④ Fill in enough oil, or replace lubricating oil
<b>(2) It is difficult to gear, or unable to gear on</b> ① The clutch does not separated completely ② Mesh sleeve end face and gear end face are abraded seriously, or damaged	① Remedy as per clutch troubles ② Replace or repair
<b>(3) The gear disconnects itself</b> ① Poking fork positioning slot is worn seriously ② Interlock pin spring pressure isn't enough ③ Spline of teeth seat are worn	① Adjust or replace poking fork shaft ② Adjust or replace the spring ③ Replace teeth seat

## 7.3 Rear axle

<b>Troubles &amp; possible causes</b>	<b>Fixing methods</b>
<b>(1) Noise increased in the bevel transmission</b> ① Bearing clearance of the small helical bevel is too large ② Gear engagement is abnormal ③ Differential shaft abraded and seized ④ The planetary gear or washer abraded ⑤ Differential bearing abraded or damaged	① Adjust ② Adjust ③ Replace ④ Replace gear or washer ⑤ Replace bearing
<b>(2) Bearings of helical bevel pinion and differential shaft are with high temperature</b> ① Pre-tension is too much ② Poor lubrication	① Adjust ② Check oil level, replenish if need

## 7.4 Braking system

Troubles & possible causes	Fixing methods
<b>(1) Brake fails</b> ① The brake disk is worn seriously, or worn eccentrically. ② Free path of brake pedal is too large	① Put air out of pipe ② Readjust
<b>(2) Tractor steer wander during braking</b> ① The left and right brake pedals' free pathes are different ② The brake disk is damaged in one side ③ Air pressures in the two rear tires are different	① Adjust ② Replace ③ Check up and air up the tires as per regulation
<b>(3) The tractor is shivering at starting</b> ① The brake pedals' free pathes is too small ② Return spring's pressure is too small	① Adjust ② Replace
<b>(4) The brake cannot be separated completely and resulting in heat</b> ① Grip brake still under operational ② The brake pedals' free pathes is too small	① Loosen the grip brake ② Adjust

## 7.5 Front driven axle (4WD)

Troubles & possible causes	Fixing methods
<b>(1) The front tires are worn seriously</b> ① The front wheel rim or supporter deformed seriously ② The front wheel toe-in adjust improperly ③ The steering knuckle and two pins of oil cylinder are worn seriously ④ The air pressure is insufficient and the front axle is engaged when transporting	① Correct them ② Adjust tor-in ③ Replace pintles ④ Checkup and air up and disconnect
<b>(2) The front wheels are swaying</b> ① Bearing of front driven axle is abraded heavily ② Bearing of steering knuckle is abraded heavily ③ Clearance of front and rear supporting seat is too large ④ The front wheel rim deformed seriously ⑤ The front wheel toe-in adjust improperly	① Replace ② Replace ③ Adjust ④ Correct ⑤ Adjust

## 504G3 SERIES TRACTOR OPERATION MANUAL

⑥ Steering ball is abraded seriously	⑥ Replace
<b>(3) Too big noise</b> ① Front bevel transmission gear engage badly ② Bevel transmission bearing clearanced is too large or the bearing is broken ③ Differential shaft are worn or damaged ④ Planetary gear or washer are abraded ⑤ Final transmission bevel pair engage badly	① Adjust ② Adjust or replace ③ Replace ④ Replace ⑤ Replace or change the number of adjusting washers

### 7.6 Walking system

Troubles & possible causes	Fixing methods
<b>(1) The front wheels are swaying</b> ① Clearance of front wheel shaft bearing is too large ② Ball joint is abraded heavily ③ The front wheel toe-in adjust improperly ④ The front wheel rim deformed seriously	① Adjust to the request ② Replace ③ Adjust ④ Correct
<b>(2) The front tires are worn quickly</b> ① The front wheel toe-in adjust improperly ② The pressure of front tires is improper ③ Mistaking the direction of the tread pattern	① Adjust ② Charge the tires correctly ③ Reinstall

### 7.7 Hydraulic steering system

Troubles & possible causes	Fixing methods
<b>(1) Oil leaks</b> ① Bolt at the pipe joint loose ② Rubber ring at the pipe joint or crankshaft journal is broken ③ The washer is uneven or broken	① Fasten the bolt ② Replace ③ Replace
<b>(2) Steering is too heavy</b> ① Great pump supply oil insufficiently, inside leak or filter net in the oil case blocked. ② Air in the steering system, oil with foam ③ Steering oil case supply oil insufficiently	① Check up pump and clean filter net ② Eliminate air and checkup ③ Replenish oil to specified level

## 504G3 SERIES TRACTOR OPERATION MANUAL

<ul style="list-style-type: none"> <li>④ The oil is too gummy</li> <li>⑤ Ball valve is no of efect, and steer wheel work heavily when steer quickly or slowly, and steer powerlessly</li> <li>⑥ Steer system leak include inside or outside leak</li> <li>⑦ Safety valve             <ul style="list-style-type: none"> <li>a) Safety valve spring become weak</li> <li>b) The valve is plugged up with dirt</li> <li>c) The spring of the valve become weak or the ball is ineffective</li> </ul> </li> </ul>	<ul style="list-style-type: none"> <li>④ Replace</li> <li>⑤ Check and fix</li> <li>⑥ Checkup and eliminate</li> <li>⑦ Clean and adjust</li> </ul>
<p><b>(3) Steering failed</b></p> <ul style="list-style-type: none"> <li>① Poke pin broken or deformed</li> <li>② Interlink shaft open end broken or deformed</li> <li>③ Rotor and interlink shaft position misplace each other</li> <li>④ Steering oil case piston is damaged</li> </ul>	<ul style="list-style-type: none"> <li>① Replace poke pin</li> <li>② Replace interlink shaft</li> <li>③ Reinstall</li> <li>④ Replace</li> </ul>
<p><b>(4) The steering wheel can't return back</b></p> <ul style="list-style-type: none"> <li>① The steering shaft isn't concentric with the rotor</li> <li>② The steering shaft push the rotor to ineffective</li> <li>③ The steering shaft isn't concentric with the steering column, steering moment is too large</li> <li>④ The return spring is broken</li> </ul>	<p>Checkup and eliminate</p>
<p><b>(5) Turn the steering wheel slowly, steering force will be light, or it will be heavy</b></p> <p style="padding-left: 40px;">The flux of constant pump is too small</p>	<p>Check and adjust</p>

### 7.8 PTO

Troubles & possible causes	Fixing methods
<p><b>(1) PTO dosen't work</b></p> <ul style="list-style-type: none"> <li>① The button of PTO is broken</li> <li>② There is something wrong with the circuit</li> <li>③ The valve is broken</li> <li>④ PTO hasn't been put into gear</li> </ul>	<ul style="list-style-type: none"> <li>① Check the button</li> <li>② Check the circuit</li> <li>③ Replace</li> <li>④ Put it into gear</li> </ul>

## 504G3 SERIES TRACTOR OPERATION MANUAL

<p><b>(2) The PTO has no power</b></p> <ul style="list-style-type: none"> <li>① The driven plate lining in the hydraulic clutch abraded heavily or the abrasion lean to one side</li> <li>② The valve is broken</li> <li>③ The hydraulic clutch leaks heavily</li> </ul>	<ul style="list-style-type: none"> <li>① Replace</li> <li>② Replace</li> <li>③ Replace</li> </ul>
<p><b>(3) The PTO can't be separated completely</b></p> <ul style="list-style-type: none"> <li>① The button is broken</li> <li>② The driven plate lining in the hydraulic clutch has been locked up</li> <li>③ Return spring of the hydraulic clutch is broken</li> </ul>	<ul style="list-style-type: none"> <li>① Check the button</li> <li>② Check and repair</li> <li>③ Replace</li> </ul>

### 7.9 Hydraulic Hitch System

Troubles & possible causes	Fixing methods
<p><b>(1) Cannot lift whenever light load or heavy load</b></p> <ul style="list-style-type: none"> <li>① Oil returning valve block at open position</li> <li>② Gear pump does not work                             <ul style="list-style-type: none"> <li>a) Oil level in the lifter is too low</li> <li>b) Filter net blocked seriously</li> </ul> </li> </ul>	<ul style="list-style-type: none"> <li>① Check and clean valve</li> <li>②                             <ul style="list-style-type: none"> <li>a) Replenish oil to specified level</li> <li>b) Clean or replace net</li> </ul> </li> </ul>
<p><b>(2) Lift up if light load,unable lift or lift slowly when with heavy load</b></p> <ul style="list-style-type: none"> <li>① Gear pump abraded seriously</li> <li>② Any of the valves leaks</li> <li>③ Seal rings of the oil intake pipe or the pump is broken</li> </ul>	<ul style="list-style-type: none"> <li>① Fix or replace the pump</li> <li>② Check, clean and repair it</li> <li>③ Replce</li> </ul>
<p><b>(3) Implement shivering during lifting, Static sink goes fast</b></p> <ul style="list-style-type: none"> <li>① Distributor single direction valve seal poorly</li> <li>② Sink valve seal poorly</li> <li>③ Oil cylinder safety valve leak</li> <li>④ The hydraulic output has been jammed to seal badly</li> <li>⑤ Sink speed control valve is damaged to leak</li> <li>⑥ O ring of oil cylinder piston damage to leak</li> </ul>	<ul style="list-style-type: none"> <li>① Clean and repair if needed</li> <li>② As the same</li> <li>③ As the same</li> <li>④ As the same</li> <li>⑤ Replace</li> <li>⑥ Replace</li> </ul>



## 504G3 SERIES TRACTOR OPERATION MANUAL

<p><b>(4) Sink speed of the implement is normal, but it can't reach the toppest position or exceed the toppest position</b> Extension rod is too short or too long</p>	Adjust the length
<p><b>(5) Implement cannot be put down</b></p> <ul style="list-style-type: none"> <li>① Main control valve blocked</li> <li>② Sink valve blocked</li> <li>③ Sink speed control valve is screwed too much</li> <li>④ Rapid lift lever is flexural</li> </ul>	<ul style="list-style-type: none"> <li>① Clean it</li> <li>② Clean it</li> <li>③ Loose it</li> <li>④ Adjust the rapid lift lever backwards</li> </ul>

### 7.10 Electrical system

Troubles & possible causes	Fixing methods
<p><b>(1) Accumulator doesn't have enough power</b></p> <ul style="list-style-type: none"> <li>① Pillar plate sulfurized seriously</li> <li>② There is something wrong with the generator or regulator</li> <li>③ Wire connect unwell</li> </ul>	<ul style="list-style-type: none"> <li>① Charge again and remove the sulfuration</li> <li>② Check the generator or regulator</li> <li>③ Check and repair</li> </ul>
<p><b>(2) The temperature of the accumulator is too high</b> Current is too large</p>	Check and adjust
<p><b>(3) The generator does not generate power</b> Rotor coil broken</p>	Check and repair
<p><b>(4) The generator does not charge enough or charge unsteadily</b></p> <ul style="list-style-type: none"> <li>① Transmission V belt looses, making generator rate decline</li> <li>② oint of the wire looses</li> <li>③ Carbon is broken</li> <li>④ Regulator is damaged</li> </ul>	<ul style="list-style-type: none"> <li>① Adjust</li> <li>② Fasten the bolt</li> <li>③ Check and repair</li> <li>④ Check and repair</li> </ul>
<p><b>(5) There is a noise in the generator</b></p> <ul style="list-style-type: none"> <li>① The generator is installed incorrectly</li> <li>② Bearing of generator is broken</li> <li>③ The rotor meet with the stator or something else</li> </ul>	<ul style="list-style-type: none"> <li>① Reinstall</li> <li>② Replace</li> <li>③ Repair</li> </ul>
<p><b>(6) The starter motor does not work</b></p> <ul style="list-style-type: none"> <li>① The wire is broken or wire joint dosen't connect correctly</li> <li>② The fuse is broken</li> <li>③ Battery volume is insufficient</li> </ul>	<ul style="list-style-type: none"> <li>① Weld or replace the wire, clean the dirt and fasten the bolt</li> <li>② Replace</li> <li>③ Charge the battery</li> </ul>

## 504G3 SERIES TRACTOR OPERATION MANUAL

④ The carbon brush and the commutator contact poorly ⑤ Starter motor is broken or shorten	④ Check and adjust carbon brush spring pressure ⑤ Check and repair
<b>(7) The starter motor starts weakly, and cannot start the engine</b> ① Bearing abraded seriously and pivot touch housing ② The carbon brush and the collector contact poorly ③ The commutator surface is burnt or stained with oil ④ Wire connect unwell ⑤ The main touch point of electromagnetic switch burnt out, and have poor contact ⑥ Battery volume is insufficient	① Replace bearing ② Adjust ③ Clean the oil and grind by “0” model non metal sand paper ④ Fasten joint ⑤ Grind by “0” model non metal sand paper ⑥ Recharge
<b>(8) Starter motor continue rotate when motor had started</b> ① Copper disk in the motor relay keep link with two touch points ② Distance of the copper disk in the motor relay is improper	① Check and repair ② Adjust
<b>(9) The starter motor rotate before the gears are engaged, and cause the gear end hit each other</b> Distance of the copper disk in the motor relay is too small	Adjust

### 7.11 Heating system

Troubles & possible causes	Fixing methods
<b>(1) Heater does not work</b> ① Line break ② Motor damage ③ Heater switch is broken ④ Fuse off	① Overhaul ② Overhaul or replace ③ Overhaul ④ Replace

## Chapter 8 Appendix

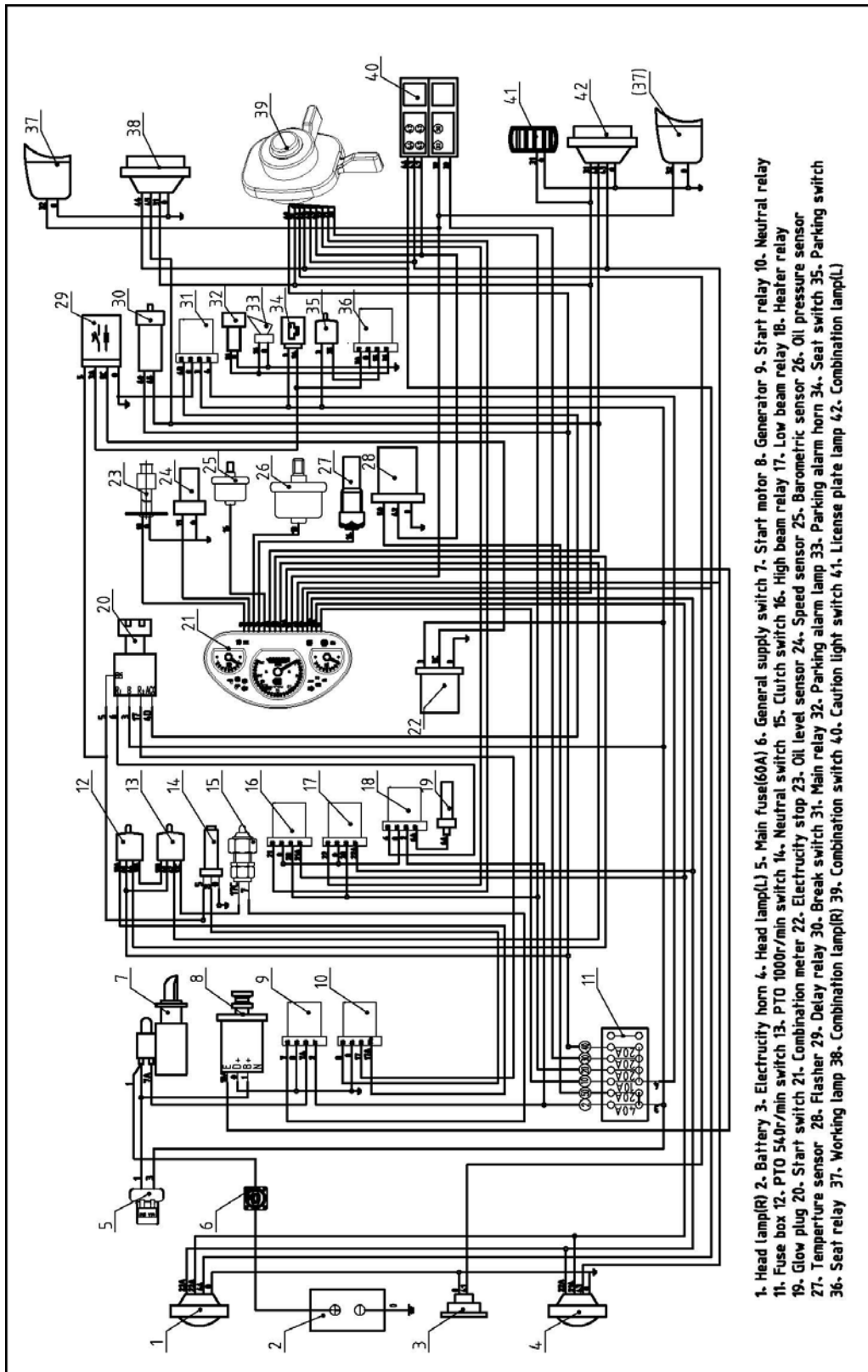
### Appendix 1 Standards and Regulations

NO.	Standard NO.	Name of standard
1	Q/3204BYN008	DF25-45G2 系列轮式拖拉机 DF25-45G2 series wheeled tractor
2	(EU) No 167/2013	On the approval and market surveillance of agricultural and forestry vehicles
3	(EU) No 1322/2014	supplementing and amending Regulation (EU) No 167/2013 of the European Parliament and of the Council with regard to vehicle construction and general requirements for the approval of agricultural and forestry vehicles
4	(EU) 2015/68	supplementing Regulation (EU) No 167/2013 of the European Parliament and of the Council with regard to vehicle braking requirements for the approval of agricultural and forestry vehicles
5	(EU) 2015/96	supplementing Regulation (EU) No 167/2013 of the European Parliament and of the Council as regards environmental and propulsion unit performance requirements of agricultural and forestry vehicles
6	(EU) 2015/208	supplementing Regulation (EU) No 167/2013 of the European Parliament and of the Council with regard to vehicle functional safety requirements for the approval of agricultural and forestry vehicles
7	(EU) 2015/504	implementing Regulation (EU) No 167/2013 of the European Parliament and of the Council with regard to the administrative requirements for the approval and market surveillance of agricultural and forestry vehicles
8	GB10395.1-2001	农林拖拉机和机械 安全技术要求 第一部分 总则 Tractors and machinery for agriculture and forestry--Technical means for ensuring safety--Part 1:General
9	GB15369-2004	农林拖拉机和机械 安全技术要求 第3部分: 拖拉机 Tractors and machineryfor agriculture and forestry--Technical means for ensuring safety--Part 3:Tractors
10	GB/T15370-2004	农业轮式和履带拖拉机 通用技术条件 General requirement of agriculturalwheeled tractors and crawler tractors
11	GB16151.1-2008	农业机械运行安全技术条件 第1部分: 拖拉机 Technical requirements of operating safety for agricultural machinery - Part 1: Tractor
12	JB/T6702-2004	拖拉机产品图样及设计文件编号规则 code rule for tractor part drawings and designing files

**Appendix 2 Tightening Torque Table of Main Bolts and Nuts**

<b>No.</b>	<b>Installation position</b>	<b>specifications</b>	<b>Tightening torque(N·m)</b>	<b>Intensity grade</b>
1	Connecting bolt for engine and clutch housing	M10	41~51	Grade 8.8
2	Connecting bolt and screw for clutch housing and gearbox housing, gearbox housing and rear axle housing, rear axle housing and lifter housing	M12	73~89	Grade 8.8
3	Connecting bolt and screw for final transmission housing and gearbox housing	M12	73~89	Grade 8.8
4	Connecting bolt for differential housing	M10	41~51	Grade 8.8
5	Connecting bolt for spiral bevel gear and differential housing	M10×1	46~56	Grade 8.8
6	Connecting bolt for bearing seat of spiral bevel pinion and rear axle housing	M12	60-70	Grade 8.8
7	Connecting bolt for differential gear shaft housing and rear axle housing	M12	73~89	Grade 8.8
8	Bolt for steering box	M14	120~140	Grade 8.8
9	Connecting bolt for driving axis housing	M16	50~60	
10	Connecting bolt for driving wheel hub and support-hell	M16	200~240	
11	Connecting bolt for front wheel hub and support-hell	M18×1.5	243~285	Grade 8.8

## Appendix 3 Scheme of the electric system



## 504G3 SERIES TRACTOR OPERATION MANUAL

### Appendix 4 List of damageable parts

No.	Code	Name	Qty.	Remarks
1	404-11.48.020	Left headlights	1	
2	404-11.48.021	Right headlights	1	
3	404-11.48.022	Left tail lamps	1	
4	404-11.48.023	Right tail lamps	1	
5	804-6.48.024	Working lights	2	
6	504G3.48.021	S116 Turn signal lights	2	
7	504G3.48.025	Fuse box	1	
8	504G3.47.015	Windshield	2	
9		Rearview mirror		
10	804-6.58.025	Oil filter	1	

### Appendix 5 List of Attached Tools

No.	Code	Name	Qty.	Remarks
1	GB3390.1-89	Socket head S=13	1	
2		Socket head S=16	1	
3		Socket head S=18	1	
4		Socket head S=24	1	
5	GB3390.2-89	Square coupler S=12.5	1	
6		Tommy bar L=300	1	
7		Square drive with extension bar	1	
8		double-ended wrench 8×10	1	
9	GB4440-94	double-ended wrench	1	
10	GB4953-85	Slip joint plier 150mm (6 " )		
11		Grease gun	1	
12		jack	1	Optional
13		Oil gun	1	Optional
14		Tyre pressure gauge	1	Optional

## Appendix 6 Mechanical couplings

### 6.1、 Clevis Type

#### 1. TECHNICAL DATA

##### 1.1. MAKER

Knegt Quality Tractors Europe, Habraken 1207, 5507TB Veldhoven, Netherlands

##### 1.2. TYPE

Tractor clevis mechanical coupling – non-automatic trailer coupling

504G3.35B.001(clevis type) according to directive 2009/144/EEC Annex VI as amended by 2013/8/EU tractor coupling and was found comply in all respects

Type-approval number: CE: e11 XXXX

Technically permissible trailer mass: 7,0 t

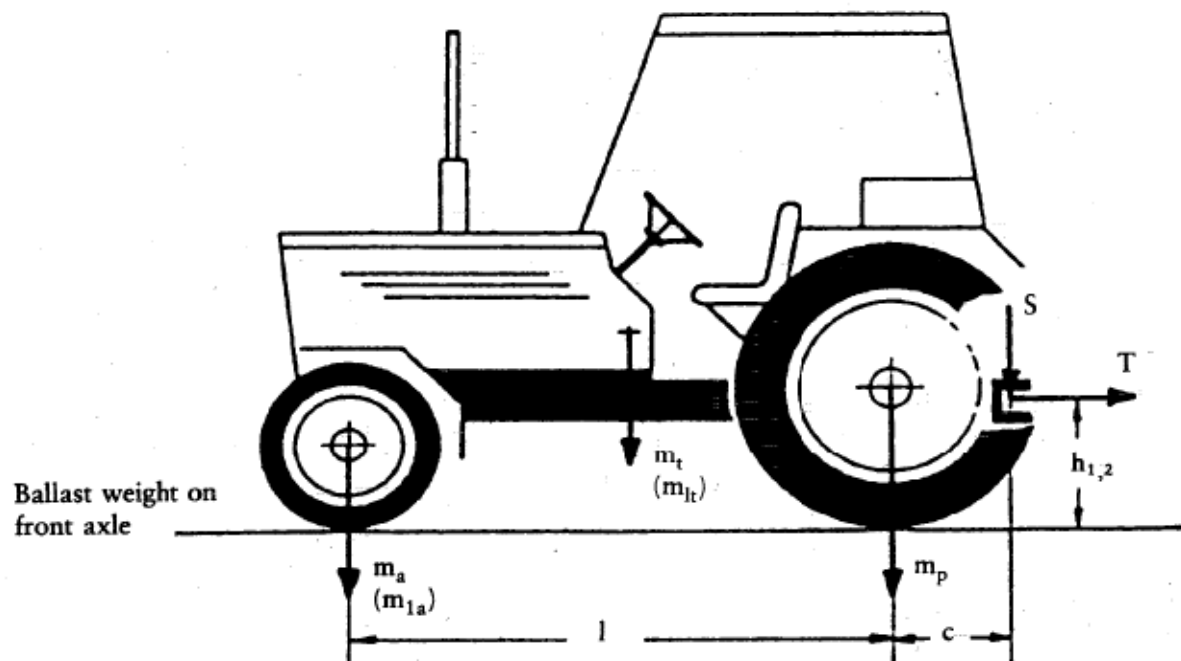
Test load: 10.0 t

Technically permissible static vertical load: 1000kg

#### 2. MOUNTING PRESCRIPTIONS

##### 2.1. HEIGHT ABOVE THE GROUND OF THE COUPLING DEVICE (H)

See figure below:



## 504G3 SERIES TRACTOR OPERATION MANUAL

---

All tractors with a loaded mass exceeding 2,5 tonnes must be fitted with a trailer coupling having a ground clearance satisfying one of the following relations:

$$h_1 \leq \frac{(m_a - 0.2 \times m_t) \times l - (S \times c)}{0.6 \times (0.8 \times m_t + S)}$$

Or

$$h_1 \leq \frac{(m_{ta} - 0.2 \times m_t) \times l - (S \times c)}{0.6 \times (0.8 \times m_{tt} - 0.2m_t + S)}$$

where:

$m_t$ : mass of the tractor,

$m_{tt}$ : mass of the tractor with ballast weight on the front axle,

$m_a$ : weight on the front axle of the unladen tractor,

$m_{ta}$ : weight on the front axle of the tractor with ballast weight on the front axle,

$l$ : tractor wheelbase,

$S$ : vertical load on the coupling pin

$c$ : distance between the reference centre of the mechanical coupling and the vertical plane passing through the axle of the rear wheels of the tractor .

### 2.2. ASSEMBLY

See drawing no. 504G3.35B.001.

Use only bolts M16 8.8.

Tightening torque: 225 Nm.

### **CAUTION**

Secure all pins with cotter.





## 6.2、 Swing drawbar

### 1. TECHNICAL DATA

#### 1.1. MAKER

Knegt Quality Tractors Europe, Habraken 1207, 5507TB Veldhoven, Netherlands

#### 1.2. TYPE

Tractor clevis mechanical coupling – non-automatic trailer coupling

504G3.53.001(tractor drawbar) according to directive 2009/144/EEC Annex IV as amended by 2013/8/EU tractor coupling and was found comply in all respects

Type-approval number: CE: e11 XXXX

#### 1.3. TECHNICAL DATA

Technically permissible trailer mass: 6,0 t

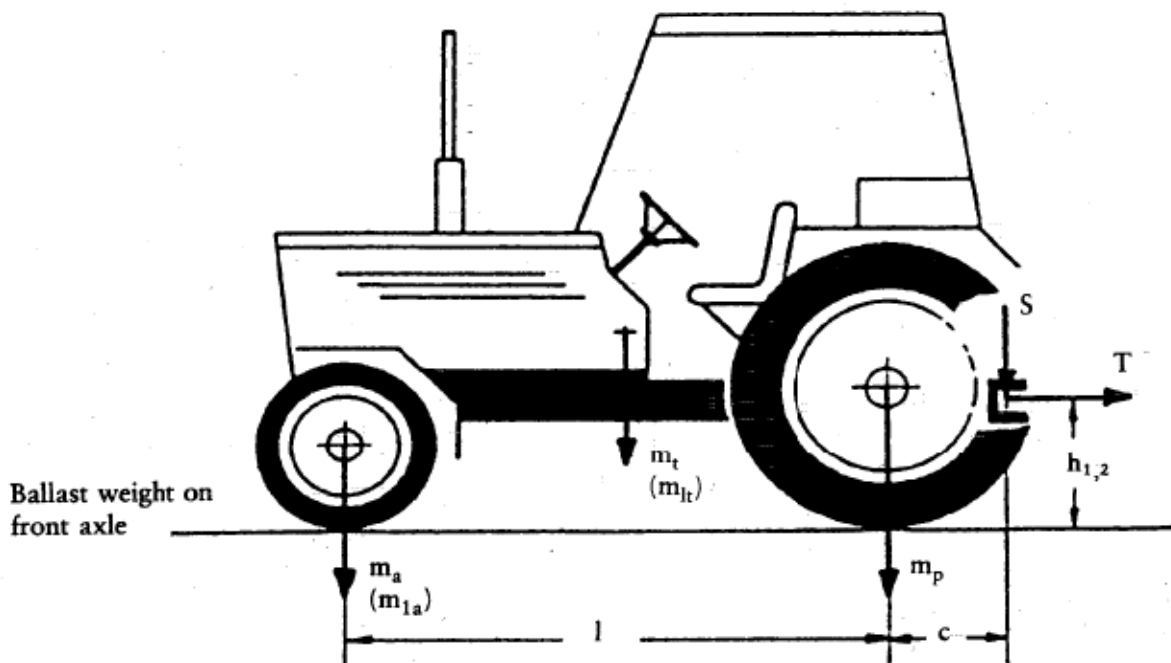
Test load: 9,0 t

Technically permissible static vertical load: 160kg

### 2. MOUNTING PRESCRIPTIONS

#### 2.1. HEIGHT ABOVE THE GROUND OF THE COUPLING DEVICE (H)

See figure below:



## 504G3 SERIES TRACTOR OPERATION MANUAL

---

All tractors with a loaded mass exceeding 2,5 tonnes must be fitted with a trailer coupling having a ground clearance satisfying one of the following relations:

$$h_1 \leq \frac{(m_a - 0.2 \times m_t) \times l - (S \times c)}{0.6 \times (0.8 \times m_t + S)}$$

Or

$$h_1 \leq \frac{(m_{la} - 0.2 \times m_t) \times l - (S \times c)}{0.6 \times (0.8 \times m_{lt} - 0.2m_t + S)}$$

where:

$m_t$ : mass of the tractor,

$m_{lt}$ : mass of the tractor with ballast weight on the front axle,

$m_a$ : weight on the front axle of the unladen tractor,

$m_{la}$ : weight on the front axle of the tractor with ballast weight on the front axle,

$l$ : tractor wheelbase,

$S$ : vertical load on the coupling pin

$c$ : distance between the reference centre of the mechanical coupling and the vertical plane passing through the axle of the rear wheels of the tractor .

### 2.2. ASSEMBLY

See drawing no. 504G3.53.001.

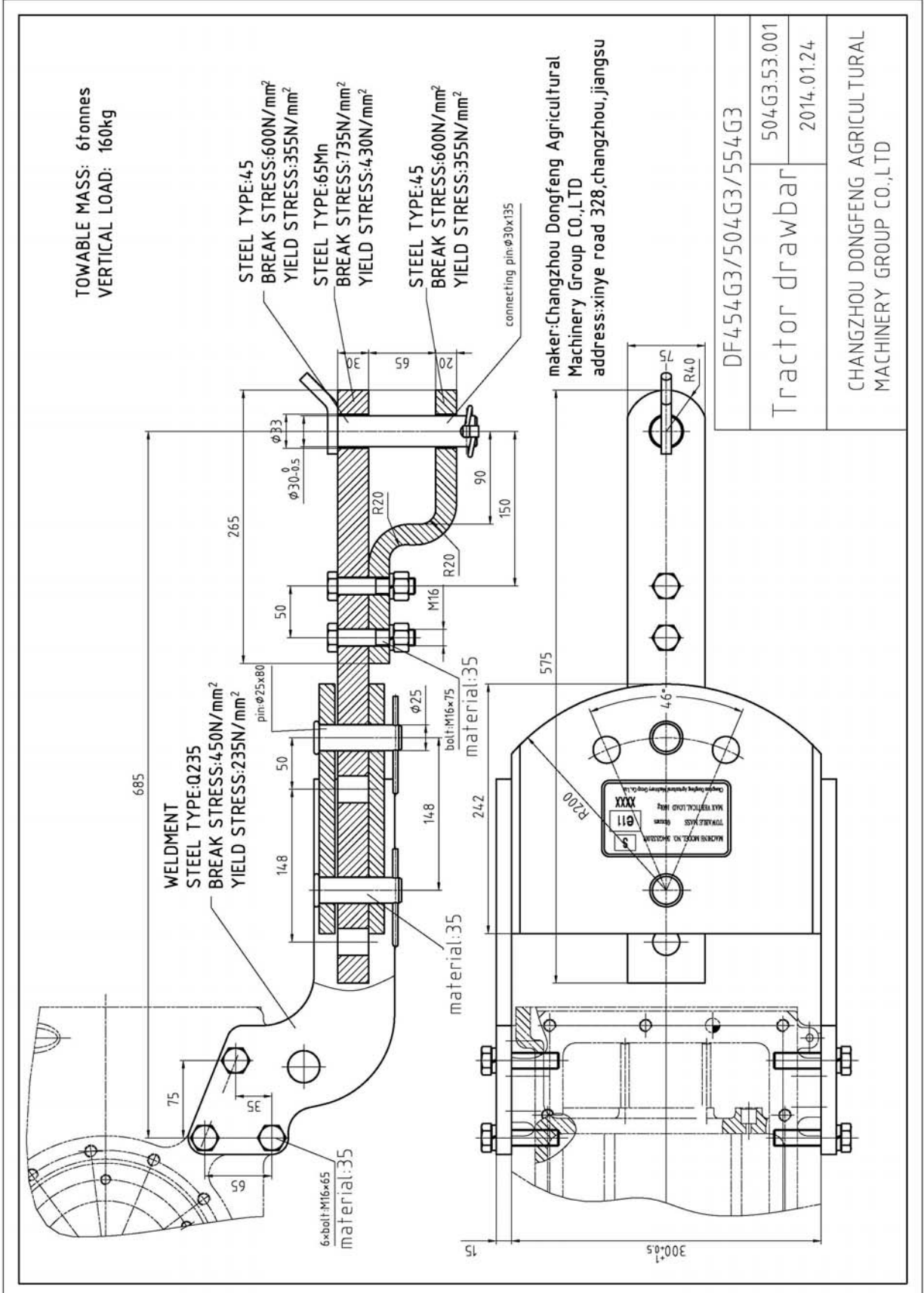
Use only bolts M16 8.8.

Tightening torque: 225 Nm.

### **CAUTION**

Secure all pins with cotter.

# 504G3 SERIES TRACTOR OPERATION MANUAL



---

















# 504G3 SERIES TRACTOR OPERATION MANUAL

---

## Index

1000h maintenance.....	67	Hoist tractor.....	51
100h maintenance.....	66	Hydraulic Hitch System .....	87
10h maintenance.....	65	Hydraulic lift system control lever.....	52
250h maintenance.....	66	Hydraulic steering system .....	85
500h maintenance.....	66	Identifying your machine .....	17
50h maintenance.....	66	Ignition Switch .....	33
Adjust Seat and Steering Wheel .....	41	Instrument and Controls .....	32
Adjustment of parking braking system.....	73	Instrument Panel.....	34
Adjustment of rockshaft system .....	80	Instrument Panel and Switch.....	33
Adjustment of service braking system.....	73	Insurance device.....	62
Adjustment of the Brake.....	72	Jack tractor .....	51
Adjustment of the Chassis .....	73	List of Attached Tools .....	93
Adjustment of the clutch .....	71	List of damageable parts .....	93
Adjustment of the engine.....	71	Machine Identification Plate .....	17
Adjustment of the Front Axle (4WD).....	75	Maintenance after running-in .....	30
Adjustment of the toe-in.....	79	Measures for emergency .....	16
Adjustment of the wheel track.....	79	Mechanical couplings.....	95
Application Packing List .....	108	Noise .....	25
Ballast.....	59	Oil and lubricants .....	64
Battery .....	61	Oil Pressure Indicator.....	45
Before Starting the Engine .....	43	Operating the Engine.....	43
Braking system.....	84	Operating the tractor safely .....	6
Capacities .....	24	Optional Accessories .....	108
Charging System Indicator.....	45		
Check Instruments after Starting .....	45	Periodic Service .....	65
Clutch .....	82	Preparation after Storage.....	70
Combination Switch.....	36	Preparation before Running-in of the tractor .....	27
Component Identification Plates .....	18	Preparation for Storage.....	69
Coolant Temperature Gauge.....	45	PTO .....	58, 86
Draw the Tractor.....	50	Rear axle.....	83
Driving the Tractor .....	46	ROPS Certification Plate.....	18
Electrical system.....	88	Running in of hydraulic hitch system.....	28
Electricity and instrument panel .....	23	Running in of PTO .....	29
E-MARK certificate .....	101	Running in of the Tractor .....	29
Engine.....	21	Running-in of hydraulic steering system.....	28
Engine Identification Plate Location .....	18	Running-in the engine without load .....	27
Equipment .....	23	Safety first .....	5
Farm implements to be attached.....	24	Safety Instructions.....	5
Front driven axle (4WD) .....	84	Safety symbols .....	12
Gearbox .....	83	Scheme of the electric system .....	92
Generator and voltage regulator .....	60	Seat Belt .....	42
Getting on and leaving the tractor .....	40	Service Daily Before Start-Up .....	43
Heating system .....	89		

## 504G3 SERIES TRACTOR OPERATION MANUAL

---

Standards and Regulations .....	90	Tractor specification.....	19
Start in Cold Weather .....	44	Transmission .....	21
Start motor .....	61	Travelling and steering system.....	22
Start the Engine .....	43	Use 3-Point Hitch.....	56
Start the tractor .....	6, 46	Use Draw Bar.....	58
Steering Wheel .....	42	Use hydraulic output system .....	55
Stopping Tractor.....	49	Use of the 4WD.....	48
Switch plate.....	37	Use of the Brakes .....	47
Technical specification of the tractor.....	19	Use of the Differential Lock.....	47
The use of electrical systems.....	60	Use of the hydraulic steering system.....	49
Tightening Torque Table of Main Bolts and Nuts .....	91	Use of the tires .....	49
Towing loads .....	8	Use operator' s set .....	41
Tractor characteristic .....	17	Using Agricultural Implements and Machines .....	8
Tractor Controls.....	32	Using the Tractor implents .....	52
Tractor Drawbar Or Clevis type Certification Plate.....	18	Vibration.....	25
Tractor Maintenance.....	9	Walking system .....	85
Tractor maintenance during storage .....	70	Warm Up the Engine .....	45
		Watch Fuel Level .....	45



NO.DF504G3-E-2018EC

Version: NO.00.00.00

First Print: September 2018

Knegt Quality Tractors Europe

Add: Habraken 1207, 5507TB Veldhoven, Netherlands

Tel:+31-40 2558416

E-mail: [info@knegt-international.com](mailto:info@knegt-international.com)

[Http://www.knegt-international.com](http://www.knegt-international.com)