

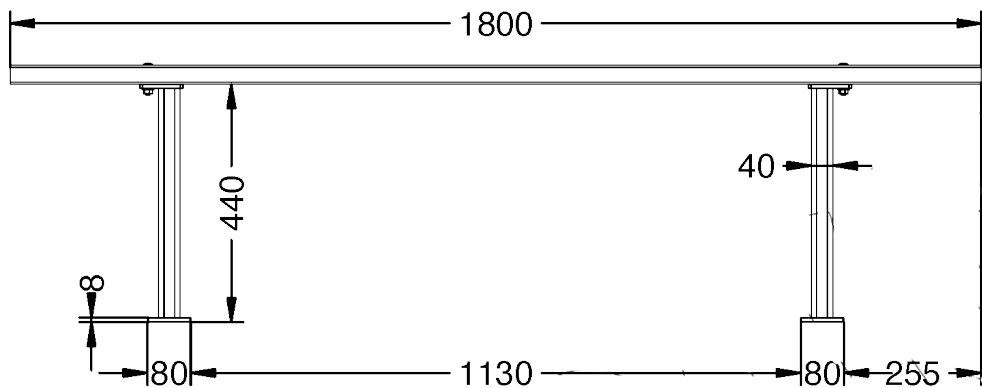

Vue de côté droite ▶

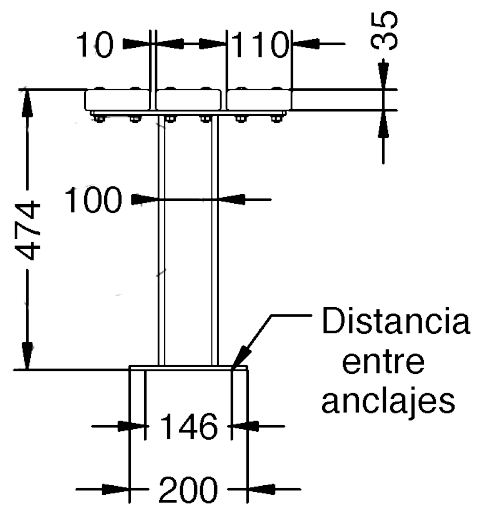

◀ **Vue de face**

Vue du bas ▶

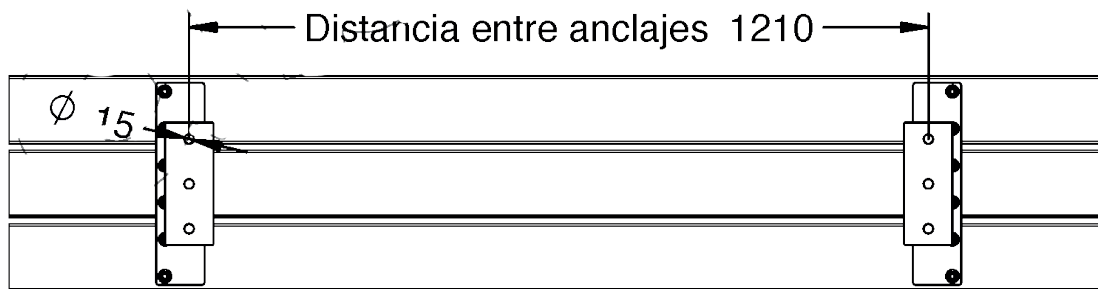

Vue du haut ▶

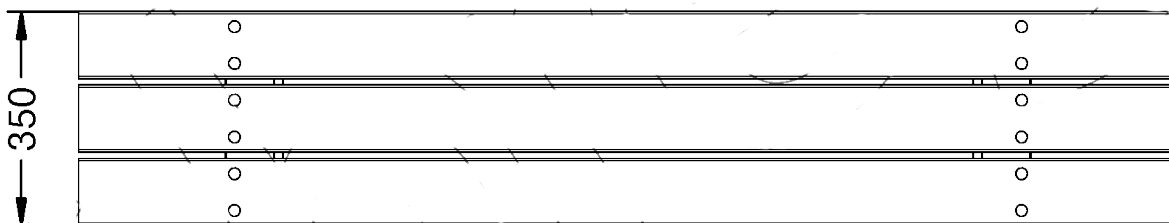

Banc MOLENE

Réf. 1262

- Banc en acier et en bois
- Pieds en acier peints Oxiron
- Lattes en bois de Guinée fongicide et hydrofuge
- Acrage 4 vis DIN933 M10x100mm (non fournies)

Matériaux : Acier et Bois de Guinée

Poids : Kg