

serie  
**FMR**



**Morella Forni®**  
morelloforni.com

Forno rotante a legna +  
piano riscaldato a gas

Four à bois rotatif +  
sole chauffée au gaz



- ✓ Les fours FMR fonctionnent principalement au bois, avec un système de chauffage auxiliaire au gaz pour la sole tournante.
- ✓ Les FMR appartiennent à la famille des fours rotatifs, où la sole, motorisée à vitesse et direction variables, donne une uniformité et une réduction des temps de cuisson.
- ✓ Les brûleurs sous la plate-forme rotative confèrent une stabilité thermique à la base du four, pour rendre le processus de cuisson plus rapide et plus homogène. La zone de combustion du bois est séparée du lit tournant par une protection métallique
- ✓ Le tiroir de chute et de récupération des cendres facilite les opérations de nettoyage, améliore la combustion du bois et les conditions hygiéniques de cuisson.
- ✓ Chauffage indépendant du sol avec gestion et contrôle thermostatique de la température
- ✓ Une grande masse réfractaire et une isolation sont conçues pour augmenter l'efficacité, et diminuer les coûts d'exploitation et les pertes de chaleur.

✓ La chaleur développée pour chauffer les stalles est véhiculée à l'intérieur du dôme, l'exploitant à nouveau, économisant la consommation du four.

✓ Trois programmes de cuisson paramétrables pour automatiser et simplifier le travail de l'opérateur

✓ Système breveté d'autonettoyage des sédiments autour du lit rotatif.



FORNO ROTANTE / FOUR ROTATIF

Le finiture della linea/Finitions • FMR



Mod./Ref.	Capacità pizze Ø 30 cm./Capacity pizzas Ø 30 cm.	Produzione oraria/Productivity per hour
FMR100	4	70 pizze/h
FMR110	5	90 pizze/h
FMR130	8	120 pizze/h
FMR150	10	160 pizze/h

Tabella forni legna serie "FMR" norma DIN 18 880/ Wood table ovens series "FMR" norm DIN 18 880

Ref./Mod.	FMR100	FMR110	FMR130	FMR150
Potenzialità gas (kW) / Gas heat output (kW)	11	11	14	18
Potenzialità legna (kW) / Wood heat output (kW)	25	28	35	46
Aria di combustione (m3/h) / Combustion air (m3/h)	165	167	173	180
Temperatura fumi scarico (°C) / Exhaust fumes temperature (°C)	85	100	110	120



certificazioni  
certifications

costruiti ed omologati  
secondo le norme  
manufactured and certified  
according to norms



• Mesure in cm ±2% • Le caractéristiques e i dati riportati nel presente catalogo possono subire variazioni senza preavviso / • Sizes in centimeters ±2% • Data and features in this catalog may change without notice

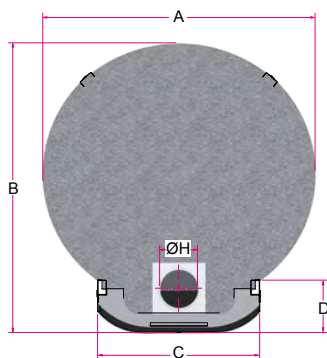
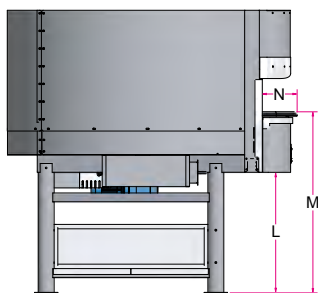
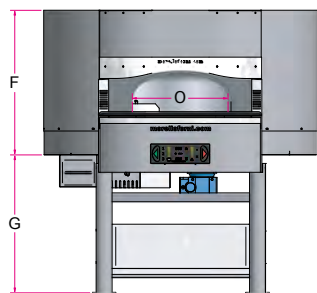

serie  
**FMR**

**Forno rotante a legna +  
piano riscaldato a gas**  
*Four à bois rotatif +  
sole chauffée au gaz*

Mod./Ref.	ØH	A	B	C	D	F	G	L	M	N	O	peso/weight (kg)
<b>FMR100</b>	25	166	177	102	30	100	94	82	122	25	55	1900
<b>FMR110</b>	25	186	196	112	30	100	94	82	122	25	65	2300
<b>FMR130</b>	25	212	212	122	30	100	94	82	122	25	75	2700
<b>FMR150</b>	25	230	245	122	30	126	94	90	124	25	82	3900

**FORNO ROTANTE/  
FOUR ROTATIF**

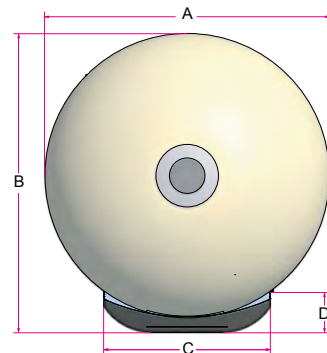
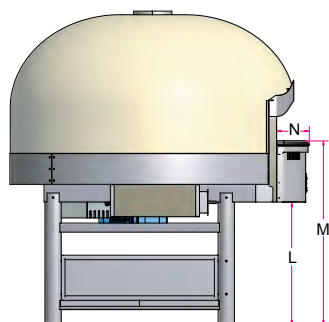
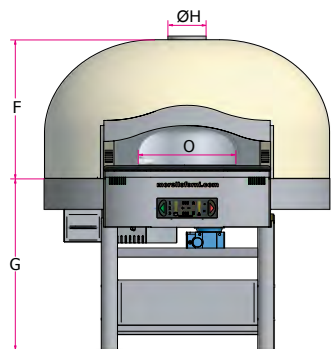

Mod./Ref.	ØH	A	B	C	D	F	G	L	M	N	O	peso/weight (kg)
<b>FMR100</b>	25	166	177	102	30	112	94	82	122	25	55	2000
<b>FMR110</b>	25	190	200	112	30	112	94	82	122	25	65	2400
<b>FMR130</b>	25	212	212	122	30	112	94	82	122	25	75	2800
<b>FMR150</b>	25	230	245	122	30	140	94	85	124	25	82	4000

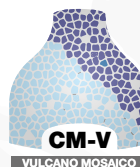
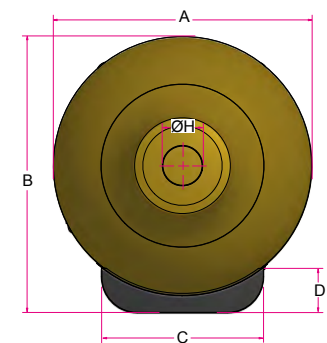
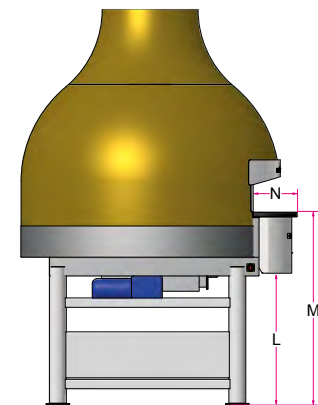
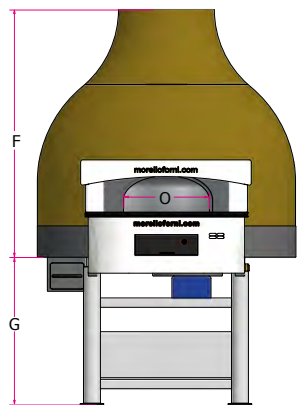

Mod./Ref.	ØH	A	B	C	D	F	G	L	M	N	O	peso/weight (kg)
<b>FMR 100</b>	25	166	177	102	30	132	94	82	122	25	55	2100
<b>FMR 110</b>	25	190	200	112	30	132	94	82	122	25	65	2500
<b>FMR 130</b>	25	212	212	122	30	132	94	82	122	25	75	2900
<b>FMR 150</b>	25	230	245	122	30	160	94	85	124	25	82	4100

*alcune nostre finiture  
quelques finitions*



**EQUIPIZZA CARMAT FRANCE**  
1469, route de Bagnol - 83920 La Motte - France  
Tel. +33 4 94 85 72 76 • Gsm + 33 6 98 72 16 65  
email: contact@carmatfrance.fr