

# FLAT TOP TOWER CRANE















**Specifications:**

- ▶ Max jib length: 84,00 m
- ▶ Capacity at max length: 2,20 t
- ▶ Max capacity: 20,00 t

**WORKS FOR YOU.™**

# KEY

## Legenda · Zeichenerklärung · Légende · Leyenda · Legenda · Условные обозначения

|   |  |
|---|--|
|    | Hoisting · Sollevamento · Heben · Levage · Elevación · Elevação · Подъем   |
|    | Trolleying · Traslazione carrello · Katzfahren · Distribution · Distribución · Distribuição · Передвижение каретки   |
|    | Slewing · Rotazione · Schwenken · Orientation · Orientació · Giro · Поворот  |
|    | Travelling · Traslazione · Schienenfahren · Translation · Traslación · Móvel · Передвижение  |
|    | Directive on noise level · Direttiva sul livello acustico · Richtlinie für den Schall-Leistungspegel · Directive sur le niveau acoustique · Directiva sobre el nivel acustico · Directiva sobre nivel de ruidos · Директива по уровню шума   |
|    | Consult us · Consultateci · Auf Anfrage · Nous consulter · Consultarnos · Consulte-nos · Проконсультироваться с нами   |
|    | Power requirements · Potenza totale richiesta · Geforderte Stromstärke · Puissance totale nécessaire · Potencia necesaria · Requisitos de energia · Требования по питанию  |
|    | Power supply · Alimentazione · Stromversorgung · Alimentation · Alimentación · Fonte de alimentação · Питание  |
|    | In service · In servizio · In Betrieb · En service · En servicio · Em serviço · При работе   |
|  | Out of service · Fuori servizio · Außer Betrieb · Hors service · Fuera de servicio · Fora de serviço · В режиме простоя  |
|  | Max. under hook height · Altezza max. sottogancio · Höchste Hakenhöhe · Hauteur maxi. sous crochet · Maxima altura bajo gancho · Alt. máx. sob o gancho · Макс высота крюка  |
|  | Without load, without ballast, max. jib and max. height · A vuoto, senza zavorra, braccio max., altezza max. · Ohne Last und Ballast, mit Maximalausleger und Maximalhöhe · A vide, sans lest, avec flèche et hauteur maximum · Sin carga, sin lastre, con pluma y altura máxima · Sem carga, sem lastro, lança máxima, altura máxima · Без груза, без балласта, на макс. Длине вспомогательной стрелы и макс. Высоте  |
|  | Counterweight · Zavorra controbraccio · Gegengewicht · Lest de contre-flèche · Lastre de contra flecha · Contrapeso · Противовес   |
|  | EN 14439-C25 out of service proof with LC1 & LC3 - wind coming from each side 100 Km/h - For different requirement please contact us · EN 14439 - C25 fuori servizio con LC1 & LC 3 - vento in ogni direzione 100 km/h - contattateci per differenti richieste · EN 14439 - C25 außer Betrieb mit LC1 & LC3 - Wind von jeder Seite 100 km/h - für abweichende Anforderungen kontaktieren Sie uns bitte · EN14439 - C25 hors service avec LC1 & LC3 - vent 100km/h de chaque côté - Nous contacter pour des caractéristiques différentes · EN 14439 - C25 fuera de servicio con LC1 & LC3 - viento de cada lado 100 km/h - contáctenos si necesita más información · EN 14439 - C25 fora de serviço com LC1 e LC3 - vento de cada lado 100 kmh - para pedidos especiais, entre em contato conosco · EN14439 - C25 не совместим с LC1 & LC3 - ветровая нагрузка не более 100км/ч - для уточнения спецификаций обращайтесь, пожалуйста, к нам |

# CONTENTS

СТТ 561А-20

Indice · Inhalt · Contenu · Contenido · Sumário · Содержание

Page · Pagina · Seite · Page · Página · Página · Страница:

|   |    |
|---|----|
| Load Diagram · Diagramma di portata · Lastkurven · Courbes de charges · Curvas de cargas · Diagrama de carga · Диаграмма грузоподъёмности ..... | 4  |
| Tower · Torre · Turm · Tour · Torre · Torre · Башня .....   | 6  |
| Mechanisms · Meccanismi · Antriebe · Mécanismes · Mecanismos · Mecanismo · Механизм .....   | 9  |
| Transportation · Trasporto · Transport · Transport · Transporte · Transporte · Транспортировка .....  | 11 |

# LOAD DIAGRAM

Diagramma di portata · Lastkurven · Courbes de charges · Curvas de cargas · Diagrama de carga · Диаграмма грузоподъёмности

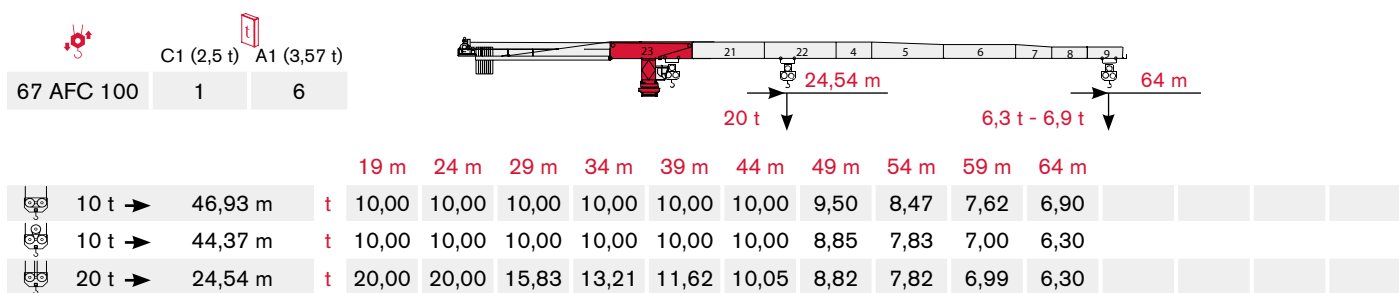
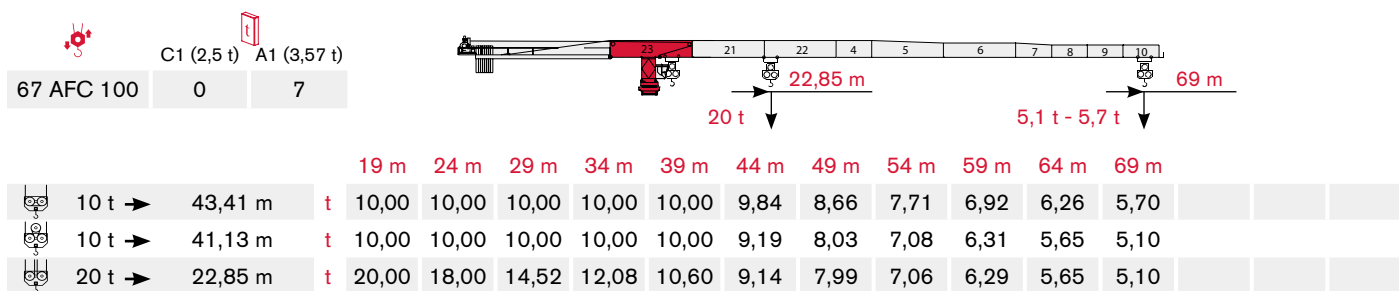
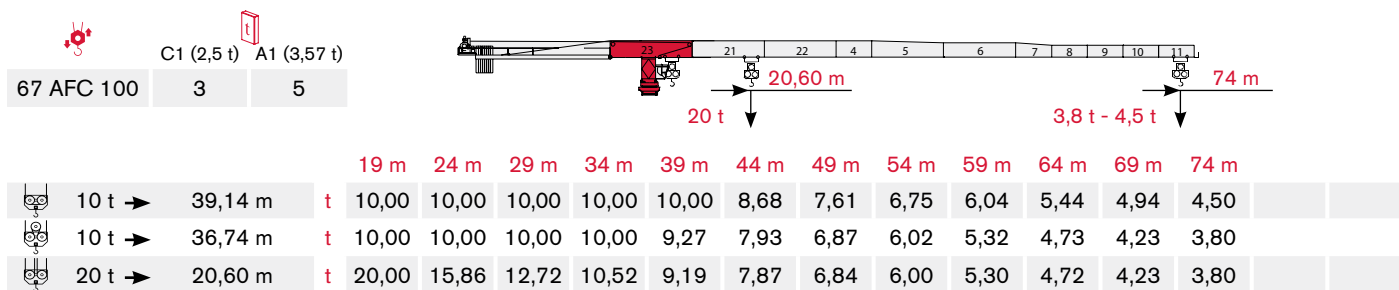
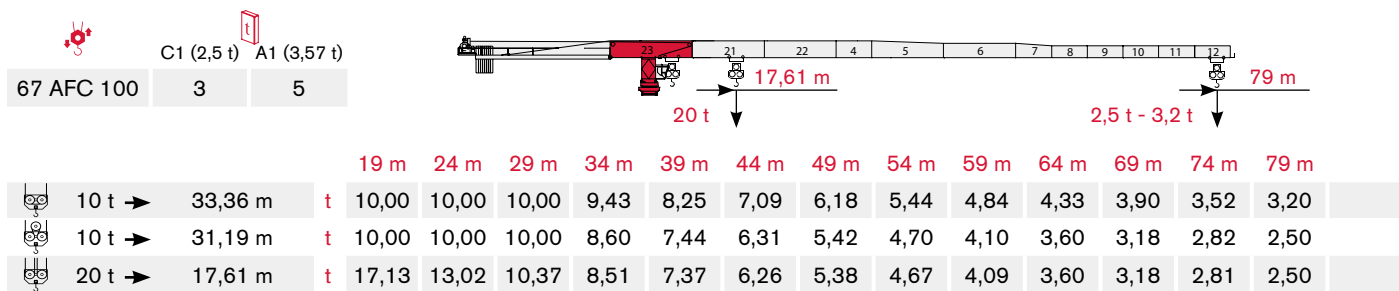
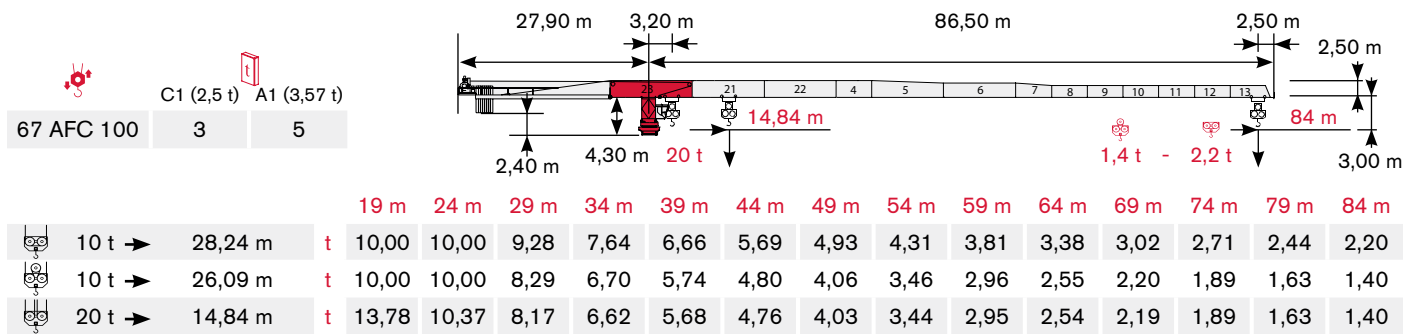

67 AFC 100 C1 (2,5 t) A1 (3,57 t)  
1 6

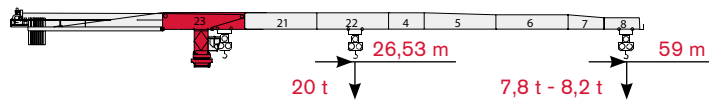

|        |         |   | 19 m  | 24 m  | 29 m  | 34 m  | 39 m  | 44 m  | 49 m  | 54 m | 59 m |  |  |  |  |
|--------|---------|---|-------|-------|-------|-------|-------|-------|-------|------|------|--|--|--|--|
| 10 t → | 49,89 m | t | 10,00 | 10,00 | 10,00 | 10,00 | 10,00 | 10,00 | 10,00 | 9,11 | 8,20 |  |  |  |  |
| 10 t → | 48,18 m | t | 10,00 | 10,00 | 10,00 | 10,00 | 10,00 | 10,00 | 9,80  | 8,70 | 7,80 |  |  |  |  |
| 20 t → | 26,53 m | t | 20,00 | 20,00 | 17,36 | 14,53 | 12,81 | 11,11 | 9,77  | 8,69 | 7,80 |  |  |  |  |

67 AFC 100 C1 (2,5 t) A1 (3,57 t)  
2 5

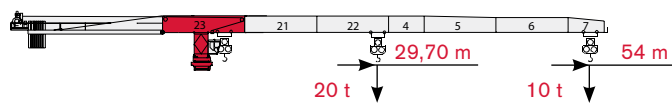

|        |         |   | 19 m  | 24 m  | 29 m  | 34 m  | 39 m  | 44 m  | 49 m  | 54 m  |  |  |  |  |  |
|--------|---------|---|-------|-------|-------|-------|-------|-------|-------|-------|--|--|--|--|--|
| 10 t → | 54,00 m | t | 10,00 | 10,00 | 10,00 | 10,00 | 10,00 | 10,00 | 10,00 | 10,00 |  |  |  |  |  |
| 10 t → | 54,00 m | t | 10,00 | 10,00 | 10,00 | 10,00 | 10,00 | 10,00 | 10,00 | 10,00 |  |  |  |  |  |
| 20 t → | 29,70 m | t | 20,00 | 20,00 | 20,00 | 16,58 | 14,64 | 12,73 | 11,22 | 10,00 |  |  |  |  |  |

67 AFC 100 C1 (2,5 t) A1 (3,57 t)  
3 4

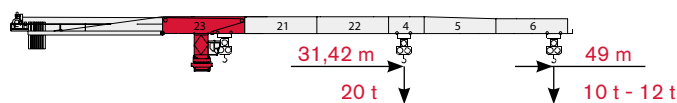

|        |         |   | 19 m  | 24 m  | 29 m  | 34 m  | 39 m  | 44 m  | 49 m  |  |  |  |  |  |  |
|--------|---------|---|-------|-------|-------|-------|-------|-------|-------|--|--|--|--|--|--|
| 10 t → | 49,00 m | t | 10,00 | 10,00 | 10,00 | 10,00 | 10,00 | 10,00 | 10,00 |  |  |  |  |  |  |
| 10 t → | 49,00 m | t | 10,00 | 10,00 | 10,00 | 10,00 | 10,00 | 10,00 | 10,00 |  |  |  |  |  |  |
| 20 t → | 31,42 m | t | 20,00 | 20,00 | 20,00 | 17,69 | 15,63 | 13,60 | 12,00 |  |  |  |  |  |  |

67 AFC 100 C1 (2,5 t) A1 (3,57 t)  
0 5

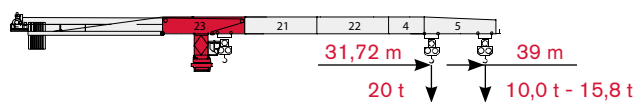

|        |         |   | 19 m  | 24 m  | 29 m  | 34 m  | 39 m  |  |  |  |  |  |  |  |  |
|--------|---------|---|-------|-------|-------|-------|-------|--|--|--|--|--|--|--|--|
| 10 t → | 39,00 m | t | 10,00 | 10,00 | 10,00 | 10,00 | 10,00 |  |  |  |  |  |  |  |  |
| 10 t → | 39,00 m | t | 10,00 | 10,00 | 10,00 | 10,00 | 10,00 |  |  |  |  |  |  |  |  |
| 20 t → | 31,72 m | t | 20,00 | 20,00 | 20,00 | 17,88 | 15,80 |  |  |  |  |  |  |  |  |

# TOWER

Torre · Turm · Tour · Torre · Torre · Башня

Standard Configurations · Installazioni Standard · Standardkonfiguration · Standard Implantations · Implantaciones Standard · Configuração padrão · Стандартная конфигурация крана

## HD23

Tower: HD23 & Basement: R1

|   | ●        | ◊        |
|---|----------|----------|
| R1  | -3460 kN | -4123 kN |
| R2  | 2652 kN  | 3451 kN  |
|  | 1150 kN  |          |

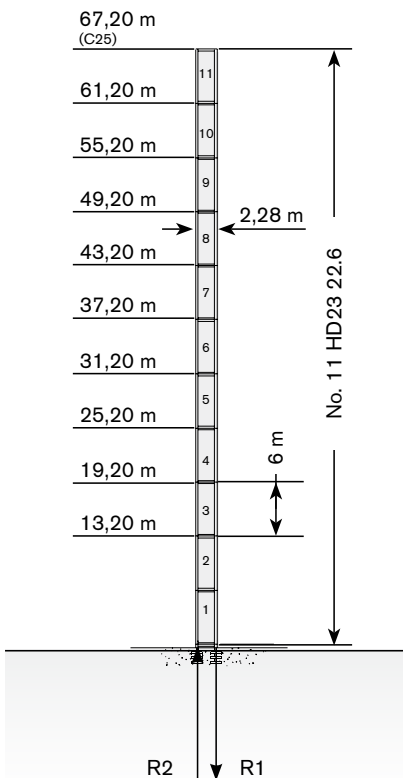

Tower: HD23 & Basement: FP1

|   | ●        | ◊        |
|---|----------|----------|
| R1  | -1620 kN | -1950 kN |
| R2  | 0 kN     | 0 kN     |
|  | 1352 kN  |          |

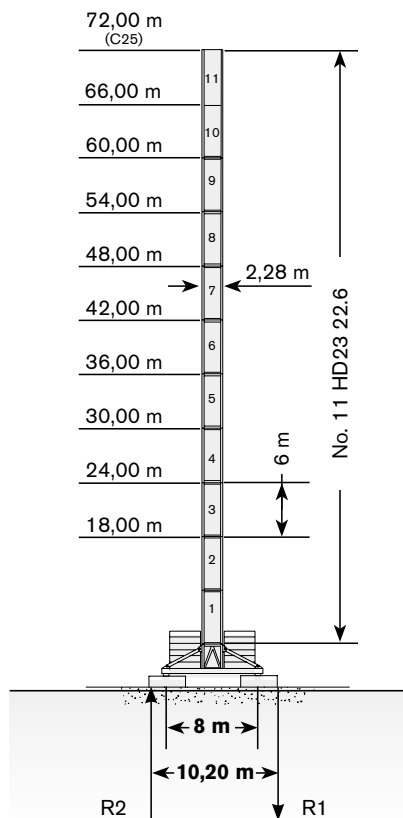

Tower: HD23 & Basement: T1

|   | ●        | ◊        |
|---|----------|----------|
| R1  | -1717 kN | -1585 kN |
| R2  | 0 kN     | 0 kN     |
|  | 1300 kN  |          |

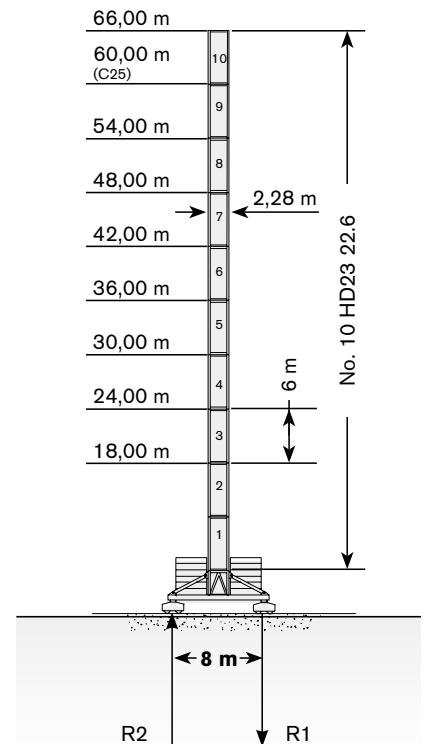

Max. under hook height · Altezza max. sotto gancio · Höchste Hakenhöhe · Hauteur maxi. sous crochet · Maxima altura bajo gancho · Alt. máx. sob o gancho · Макс высота крюка

Different heights and tower combinations are available; please consult us · Altezze diverse e combinazioni di torre sono disponibili; consultateci · Andere Höhen und Turmkombinationen auf Anfrage · Différentes hauteurs et combinaisons de tour sont disponibles; nous consulter · Hay diferentes alturas y combinaciones de torre disponibles. Consultémos · Diferentes alturas e combinações de torres disponíveis; fale conosco · Возможны другие сочетания высоты и конфигурации башни; проконсультируйтесь с нами

Tower: HD23 & Basement: R2

|   | ●        | ◄        |
|---|----------|----------|
| R1  | -4291 kN | -5546 kN |
| R2  | 3377 kN  | 4772 kN  |
|  | 1350 kN  |          |

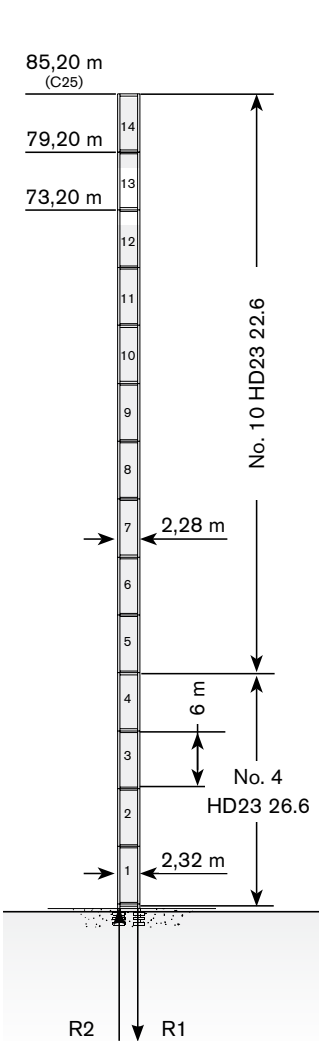

Tower: HD23 & Basement: R3

|   | ●        | ◄        |
|---|----------|----------|
| R1  | -4400 kN | -6130 kN |
| R2  | 3445 kN  | 5300 kN  |
|  | 1465 kN  |          |

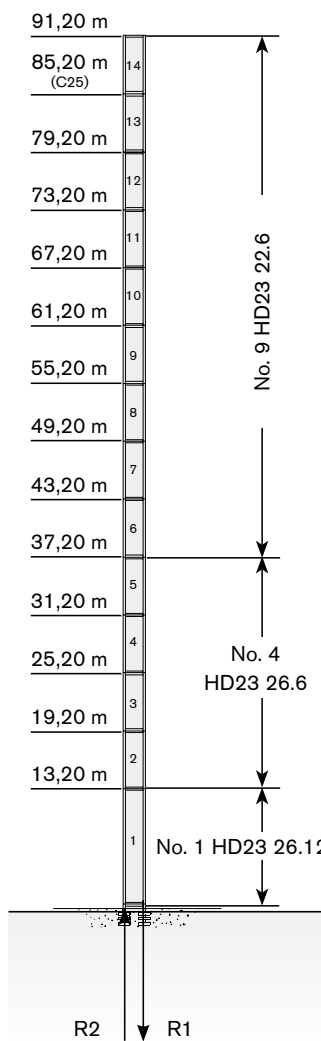

Tower: HD23 & Basement: FP6

|   | ●        | ◄        |
|---|----------|----------|
| R1  | -1550 kN | -1878 kN |
| R2  | 0 kN     | 0 kN     |
|  | 1600 kN  |          |

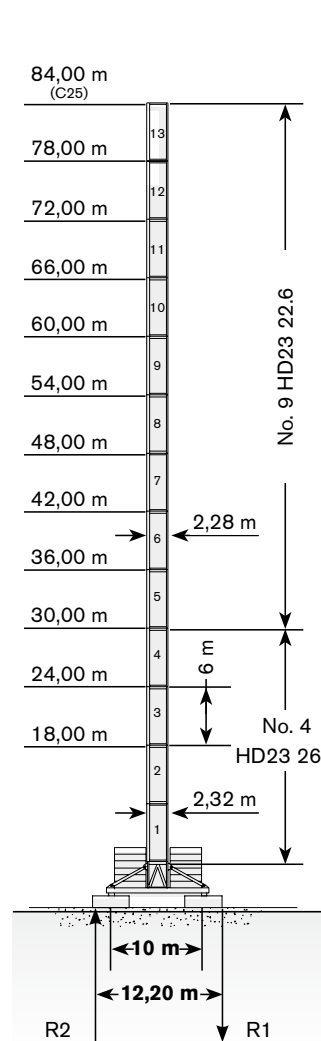

Tower: HD23 & Basement: T6

|   | ●        | ◄        |
|---|----------|----------|
| R1  | -1763 kN | -1859 kN |
| R2  | 0 kN     | 0 kN     |
|  | 1650 kN  |          |

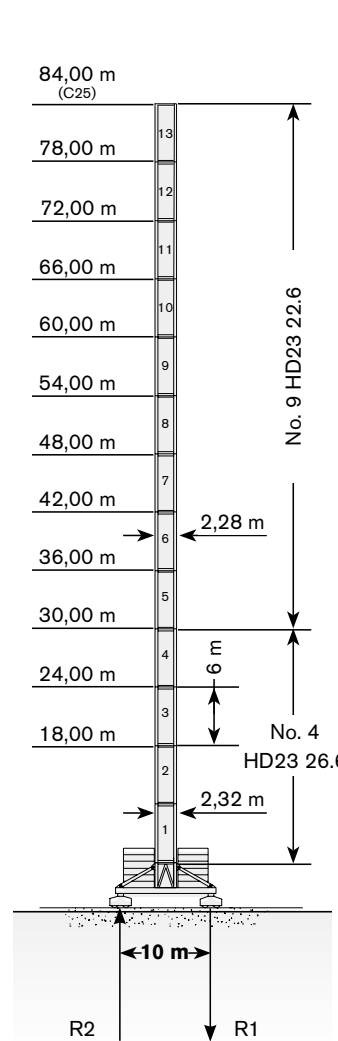

# TOWER

Torre · Turm · Tour · Torre · Torre · Башня

Other configurations · Altre Installazioni · Aufstellmöglichkeiten · Autres Implantations · Otras Implantaciones · Outras configurações · Другие конфигурации

Bottom climbing crane · Gru climbing · Kletterkran im Gebäude · Télescope sur dalles · Telescopiaje grúa trepadora · Guindaste automontante interno · Самоподъемный кран

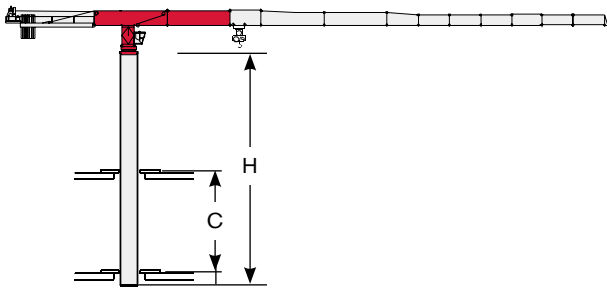

Tower: HD23-22

| C min | H max |
|-------|-------|
| 12 m  | 36 m  |
| 14 m  | 42 m  |
| 16 m  | 48 m  |

Crane tied to the structure · Gru ancorata · Geankerter Kran · Grue ancrée · Grúa anclada · Guindaste ancorado na estrutura · Кран, крепящийся к сооружению

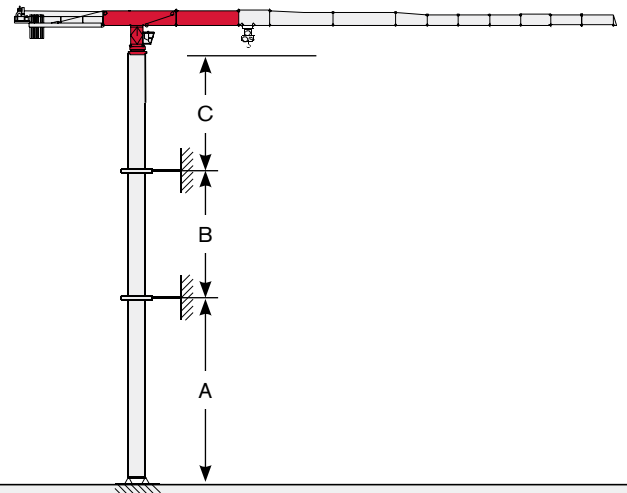

Tower: HD23 & Basement: R1

|   | min  | max  |
|---|------|------|
| A | 36 m | 60 m |
| B | 24 m | 42 m |
| C | 42 m |      |

Tower: HD23 & Basement: R2

|   | min  | max  |
|---|------|------|
| A | 36 m | 72 m |
| B | 24 m | 42 m |
| C | 42 m |      |



Different heights and tower combinations are available; please consult us · Altezze diverse e combinazioni di torre sono disponibili; consultateci · Andere Höhen und Turmkombinationen auf Anfrage · Différentes hauteurs et combinaisons de tour sont disponibles; nous consulter · Hay diferentes alturas y combinaciones de torre disponibles. Consultémos · Diferentes alturas e combinações de torres disponíveis; fale conosco · Возможны другие сочетания высоты и конфигурации башни; проконсультируйтесь с нами



# MECHANISMS

**CTT 561A-20**





**Meccanismi · Antriebe · Mécanismes · Mecanismos · Mecanismo · Механизм**

**Power supply · Alimentazione · Stromversorgung · Alimentation · Suministro eléctrico · Requisitos de energia · Требования по питанию**

|   |                |  |   |   |
|---|----------------|--|---|---|
|  | 67 AFC 100 F18 |  113 kVA* |  400V - 50Hz / 460V - 60Hz |  2000/14/CE modificata |
|---|----------------|--|---|---|

\* Average consumption · Consumo medio · Durchschnittsverbrauch · Consommation moyenne · Consumo medio · Consumo médio · Среднее потребление

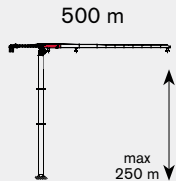
**Hoisting · Sollevamento · Heben · Levage · Elevación · Elevação · Подъем**

|   |                            |   | t   | m/min   | kW |  |
|---|----------------------------|---|-----|---------|----|---|
|  | 67 AFC 100 F18<br>(Vector) |  | 10  | 0 → 34  | 67 |  |
|   |                            |   | 8   | 0 → 41  |    |   |
|   |                            |   | 6   | 0 → 54  |    |   |
|   |                            |   | 4   | 0 → 77  |    |   |
|   |                            |   | 2,4 | 0 → 118 |    |   |
|   |                            |  | 20  | 0 → 17  |    |   |
|   |                            |   | 16  | 0 → 21  |    |   |
|   |                            |   | 12  | 0 → 27  |    |   |
|   |                            |   | 8   | 0 → 39  |    |   |
|   |                            |   | 4,8 | 0 → 59  |    |   |

# MECHANISMS

Meccanismi · Antriebe · Mécanismes · Mecanismos · Mecanismo · Механизм

Hoisting Speed · Velocità di Sollevamento · Heben Geschwindigkeit · Vitesse de Levage · Velocidad de Elevación · Velocidade de içamento · Скорость подъема

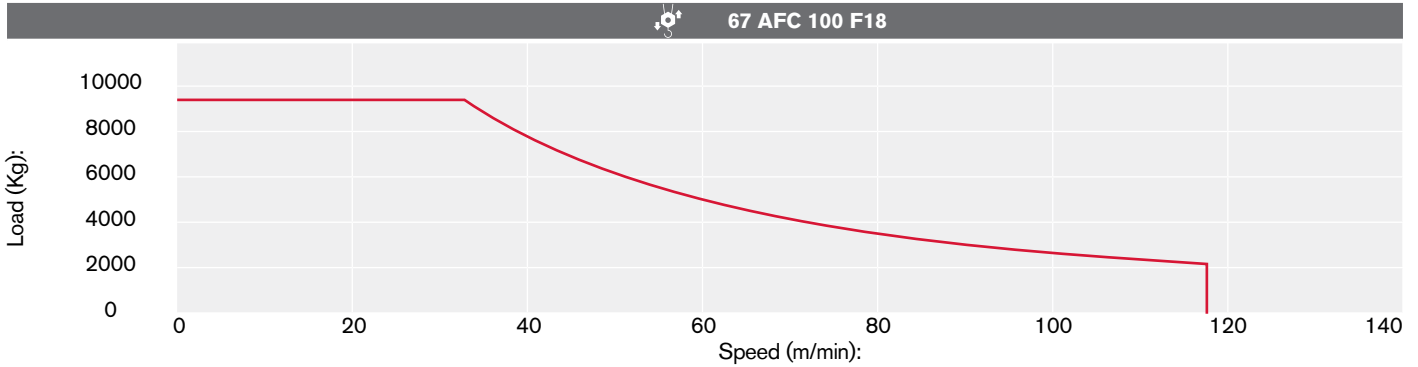

Additional Specifications · Altre movimentazioni · Weitere Leistungsdaten · Spécifications additionnelles · Otras prestaciones · Especificações adicionais · Дополнительные спецификации



|  |             |  |           |
|--|-------------|--|-----------|
|  | DVF 5 15    | 0 → 100 m/min                                  | 11 kW     |
|  | SSR 4 4 80  | 0,73 r.p.m.                                    | 4 x 80 Nm |
|  | TSR 2RG 4M8 | 12 → 24 m/min (50 Hz)<br>14 → 28 m/min (60 Hz) | 4 x 80 Nm |
|  | TSR 4RG 4M8 | 12 → 24 m/min (50 Hz)<br>14 → 28 m/min (60 Hz) | 4 x 80 Nm |
|  | <b>i</b>    |  |           |

Tower height max.

|  |             | T1        | T6        |
|--|-------------|-----------|-----------|
|  | TSR 2RG 4M8 | 48,00 m   | 48,00 m   |
|  | TSR 4RG 4M8 | > 48,00 m | > 48,00 m |

## Packing list

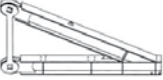



### Undercarriage

| CTT 561A-20   | DESCRIPTION · DESCRIZIONE ·<br>BESCHREIBUNG · DESCRIPTION ·<br>DESCRIPCIÓN · DESCRIÇÃO ·<br>ОПИСАНИЕ | LENGTH ·<br>LUNGHEZZA ·<br>LÄNGE ·<br>LONGUEUR ·<br>LONGITUD ·<br>COMPRIMENTO ·<br>ДЛИНА | WIDTH ·<br>LARGHEZZA ·<br>BREITE · LARGEUR ·<br>ANCHURA ·<br>LARGURA ·<br>ШИРИНА | HEIGHT ·<br>ALTEZZA ·<br>HÖHE ·<br>HAUTEUR ·<br>ALTURA · ALTURA ·<br>ВЫСОТА | QUANTITY ·<br>QUANTITÀ ·<br>MENGE · QUANTITÉ ·<br>CANTIDAD ·<br>QUANTIDADE ·<br>КОЛИЧЕСТВО | WEIGHT ·<br>PESO ·<br>GEWICHT ·<br>POIDS · PESO ·<br>PESO · ВЕС |
|---|--|--|--|---|--|---|
|    | 8×8 m UNDERCARRIAGE<br>STRUT MOUNTING TOWER SECTION  | 2,90 m   | 2,90 m   | 2,90 m  | 1  | 9150 kg   |
|    | 8×8 m<br>UNDERCARRIAGE STRUT   | 4,30 m   | 0,30 m   | 2,25 m  | 4  | 1820 kg   |
|    | 8×8 m<br>UNDERCARRIAGE INTERNAL BEAM   | 4,00 m   | 0,16 m   | 0,33 m  | 4  | 210 kg  |
|    | 8×8 m<br>UNDERCARRIAGE EXTERNAL BEAM   | 5,96m  | 0,30 m   | 0,33 m  | 4  | 626 kg  |
|   | 10×10 m UNDERCARRIAGE STRUT<br>MOUNTING<br>TOWER SECTION   | 3,00m  | 3,00 m   | 3,10 m  | 1  | 10450 kg  |
|  | 10×10 m LEFT + RIGHT<br>UNDERCARRIAGE STRUT  | 5,70 m   | 2,60 m   | 0,70 m  | 2 left +<br>2 right  | 3825 kg   |
|  | CROSSBEAM FOR TRAVELLING<br>10×10 m<br>UNDERCARRIAGE   | 7,00 m   | 2,20 m   | 0,40 m  | 2  | 2030 kg   |
|  | 10×10 m UNDERCARRIAGE<br>ELECTRICAL BOX SUPPORT<br>PLATFORM FOR TVF 4RT 4M9<br>TRAVELLING DRIVE UNIT | 5,70 m   | 2,20 m   | 2,40 m  | 1  | 1300 kg   |
|  | 10×10 m UNDERCARRIAGE<br>ELECTRICAL BOX SUPPORT<br>PLATFORM FOR TSR 4RG 4M8<br>TRAVELLING DRIVE UNIT | 5,60 m   | 2,10 m   | 3,70 m  | 1  | 645 kg  |

# TRANSPORTATION

Trasporto · Transport · Transport · Transporte · Transporte · Транспортировка







## Tower

| CTT 561A-20   | DESCRIPTION · DESCRIZIONE ·<br>BESCHREIBUNG · DESCRIPTION ·<br>DESCRIPCIÓN · DESCRIÇÃO ·<br>ОПИСАНИЕ | LENGTH ·<br>LUNGHEZZA ·<br>LÄNGE ·<br>LONGUEUR ·<br>LONGITUD ·<br>COMPRIMENTO ·<br>ДЛИНА | WIDTH ·<br>LARGHEZZA ·<br>BREITE · LARGEUR ·<br>ANCHURA ·<br>LARGURA ·<br>ШИРИНА | HEIGHT ·<br>ALTEZZA ·<br>HÖHE ·<br>HAUTEUR ·<br>ALTURA · ALTURA ·<br>ВЫСОТА | QUANTITY ·<br>QUANTITÀ ·<br>MENGE · QUANTITÉ ·<br>CANTIDAD ·<br>QUANTIDADE ·<br>КОЛИЧЕСТВО | WEIGHT ·<br>PESO ·<br>GEWICHT ·<br>POIDS · PESO ·<br>PESO · ВЕС |
|---|--|--|--|---|--|---|
|  | TOWER SECTION<br>HD23 26.6   | 6,00 m   | 2,34 m   | 2,32 m  | 1  | 6300 kg*  |
|  | TOWER SECTION<br>HD23 26.3   | 3,00 m   | 2,34 m   | 2,32 m  | 1  | 3658 kg   |
|  | TOWER SECTION<br>HD23 22.6   | 6,00 m   | 2,28 m   | 2,29 m  | 1  | 4675 kg*  |
|  | TOWER SECTION<br>HD23 22.3   | 3,00 m   | 2,29 m   | 2,28 m  | 1  | 2660 kg*  |
|  | SLEWING UNIT   | 2,96 m   | 2,32 m   | 2,24 m  | 1  | 11500 kg  |

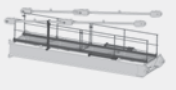
## Cab

|   |                         |        |        |        |   |         |
|---|-------------------------|--------|--------|--------|---|---------|
|  | CAB SUPPORT<br>PLATFORM | 5,54 m | 1,87 m | 2,69 m | 1 | 2000 kg |
|  | CAB TOWER SECTION       | 1,90 m | 2,50 m | 3,23 m | 1 | 3050 kg |

## Upper Part

|   |                                |         |        |        |   |             |
|---|--------------------------------|---------|--------|--------|---|-------------|
|  | COUNTERJIB<br>"1C"             | 7,16 m  | 1,99 m | 0,86 m | 1 | 3950 kg**   |
|  | COUNTERJIB<br>"3C"             | 11,66 m | 2,12 m | 1,10 m | 1 | 5800 kg**   |
|  | JIB SECTION-23<br>23TT19 23.12 | 12,00 m | 2,54 m | 2,54 m | 1 | 11000 kg*** |
|  | JIB TROLLEY 20-24 t            | 2,38 m  | 2,29 m | 1,45 m | 1 | 765 kg      |
|  | JIB SECTION-21<br>21TT19 23.10 | 10,29 m | 1,87 m | 2,54 m | 1 | 4900 kg     |
|  | JIB SECTION-22<br>22TT19 23.10 | 10,34 m | 1,87 m | 2,50 m | 1 | 4000 kg     |

| СТТ 561А-20   | DESCRIPTION · DESCRIZIONE ·<br>BESCHREIBUNG · DESCRIPTION ·<br>DESCRIPCIÓN · DESCRIÇÃO ·<br>ОПИСАНИЕ | LENGTH ·<br>LUNGHEZZA ·<br>LÄNGE ·<br>LONGUEUR ·<br>LONGITUD ·<br>COMPRIMENTO ·<br>ДЛИНА | WIDTH ·<br>LARGHEZZA ·<br>BREITE · LARGEUR ·<br>ANCHURA ·<br>LARGURA ·<br>ШИРИНА | HEIGHT ·<br>ALTEZZA ·<br>HÖHE ·<br>HAUTEUR ·<br>ALTURA · ALTURA ·<br>ВЫСОТА | QUANTITY ·<br>QUANTITÀ ·<br>MENGE · QUANTITÉ ·<br>CANTIDAD ·<br>QUANTIDADE ·<br>КОЛИЧЕСТВО | WEIGHT ·<br>PESO ·<br>GEWICHT ·<br>POIDS · PESO ·<br>PESO · ВЕС |
|---|--|--|--|---|--|---|
|    | JIB SECTION-04<br>TT19 23.05   | 5,00 m   | 1,87 m   | 2,50 m  | 1  | 1800 kg   |
|    | JIB SECTION-05<br>TT19 23.10   | 10,00 m  | 1,87 m   | 2,50 m  | 1  | 2700 kg   |
|    | JIB SECTION-06<br>TT19 20.10   | 10,29 m  | 1,87 m   | 2,18 m  | 1  | 1930 kg   |
|    | JIB SECTION-07<br>TT1920.05  | 5,28 m   | 1,87 m   | 2,18 m  | 1  | 900 kg  |
|    | JIB SECTION-08<br>TT1917.05  | 5,25 m   | 1,87 m   | 1,86 m  | 1  | 780 kg  |
|  | JIB SECTION-09<br>TT1917.05  | 5,22 m   | 1,87 m   | 1,86 m  | 1  | 640 kg  |
|  | JIB SECTION-10<br>TT1917.05  | 5,19 m   | 1,87 m   | 1,86 m  | 1  | 510 kg  |
|  | JIB SECTION-11<br>TT1917.05  | 5,16 m   | 1,87 m   | 1,86 m  | 1  | 452 kg  |
|  | JIB SECTION-12<br>TT1917.05  | 5,16 m   | 1,87 m   | 1,77 m  | 1  | 380 kg  |
|  | JIB SECTION-13<br>TT1917.05  | 5,16 m   | 1,87 m   | 1,77 m  | 1  | 325 kg  |
|  | JIB POINT<br>20/24 t   | 2,13 m   | 1,18 m   | 1,61 m  | 1  | 270 kg  |
|  | FALLS LINE<br>HOIST BLOCK<br>20-24 t   | 1,59 m   | 0,60 m   | 1,65 m  | 1  | 845 kg****  |
|  | HOIST WINCH<br>67AFC 100 F18 VECTOR<br>(without platforms, safety rails and rope)                    | 3,30 m   | 2,13 m   | 2,37 m  | 1  | 4410 kg   |

\* inclusive of ladders, platforms and assembly equipment

\*\* inclusive of tie-bars and safety rails

\*\*\* inclusive of trolley winch and accessories

\*\*\*\* ballast plates not included

# NOTES

Appunti · Notizen · Note · Apunte · Notas · Заметки

---

---

---

---

---

---

---

---

---

---

---

---

---

---

---

---

---

---

---

---

---

---

---

---

---

---

---

---

---

---

---

---

---

---

---

---

---

---

---

---

---

---

---

---

---

---

---

---

---

---

---

---

---

---

---

---

---

---

# TEREX CRANES

## Tower Cranes

Via delle Innovazioni, 17  
33074 Fontanafredda (PN)  
Italy

Ph: +39 0434 989111  
Email: info.cranes@terex.com

## Rough Terrain Cranes

Via Cassoletta, 76 - Fraz. Crespellano  
40053 Valsamoggia (BO)  
Italy

Ph: +39 051 6501011  
Email: info.cranes@terex.com

December 2019. Product specifications and prices are subject to change without notice or obligation. The photographs and/or drawings in this document are for illustrative purposes only. Refer to the appropriate Operator's Manual for instructions on the proper use of this equipment. Failure to follow the corresponding Operator's Manual when using our equipment or to otherwise act responsibly may result in serious injury or death. The only warranty applicable to our equipment is the standard written warranty applicable to the particular product and sale and Terex makes no other warranty, express or implied. Products and services listed may be trademarks, service marks or trade-names of Terex Corporation and/or its subsidiaries in the USA and other countries. All rights are reserved. Terex, the Terex Crown design and Works For You are trademarks of Terex Corporation or its subsidiaries.

Dicembre 2019. Specifiche e prezzi dei prodotti sono soggetti a modifica senza preavviso o altro obbligo. Le fotografie e i disegni in questo documento hanno esclusivamente scopo illustrativo. Consulta il Manuale dell'operatore pertinente per trovare istruzioni per l'utilizzo corretto di questo macchinario. La mancata osservanza delle istruzioni contenute nel relativo Manuale dell'operatore durante l'uso del macchinario e altri comportamenti irresponsabili possono provocare gravi lesioni, anche mortali. L'unica garanzia applicabile ai nostri macchinari è la garanzia scritta standard applicabile al particolare prodotto e alla particolare vendita e Terex è esonerata dal fornire qualsiasi altra garanzia, esplicita o implicita. I prodotti e servizi elencati possono essere dei marchi di fabbrica, marchi di servizio o nomi commerciali di Terex Corporation, e/o delle rispettive società affiliate negli Stati Uniti d'America e in molte altre nazioni. Tutti i diritti riservati. Terex, il marchio Terex Crown e Works for You sono marchi di proprietà di Terex Corporation o delle sue società affiliate.

Dezember 2019. Irrtum und Änderungen der Produktspezifikationen vorbehalten. Die in diesem Dokument enthaltenen Fotos und/oder Zeichnungen dienen rein anschaulichen Zwecken. Für den sachgemäßen Gebrauch der Maschinen ist das entsprechende Bedienerhandbuch heranzuziehen. Unsachgemäßer Umgang mit bzw. unsachgemäßer Einsatz unserer Maschinen kann zu schweren gesundheitlichen Schäden bis hin zum Tod führen. Für unsere Produkte wird ausschließlich die entsprechende, schriftlich niedergelegte Standardgarantie gewährt. Terex leistet keinerlei darüber hinausgehende Garantie, weder ausdrücklich noch stillschweigend. Die genannten Produkte und Dienstleistungen sind in den USA und anderen Ländern ggf. Marken, Dienstleistungsmarken oder Handelsnamen der Terex Corporation und/oder ihrer Tochtergesellschaften. Alle Rechte vorbehalten. Terex, das Terex Kronenlogo und Works For You sind Marken in Eigentum der Terex Corporation bzw. ihrer Tochtergesellschaften.

Décembre 2019. Les caractéristiques et prix des produits peuvent faire l'objet de modifications sans notification préalable. Les photographies ou dessins présentés dans ce document servent uniquement à des fins d'illustration. Pour connaître les instructions relatives à l'utilisation correcte de cet équipement, veuillez vous référer au manuel de l'utilisateur correspondant. Le non-respect du manuel d'utilisateur correspondant lors de l'utilisation de notre équipement ou des actes irresponsables risquent de provoquer de graves blessures, voire un décès. La seule garantie applicable à nos équipements est la garantie écrite standard applicable au produit et à la vente spécifiques. Terex ne délivre aucune autre garantie, expresse ou implicite. Les produits et les services mentionnés peuvent être des marques, des marques de service ou des appellations commerciales de Terex Corporation et/ou de ses filiales aux États-Unis et dans d'autres pays. Tous droits réservés. Terex, le design Terex Crown et Works For You sont des marques déposées de Terex Corporation ou de ses filiales.

Diciembre 2019. Las especificaciones y los precios de los productos están sujetos a cambios sin necesidad de previo aviso ni ninguna otra obligación. Las fotografías y/o dibujos de este documento tienen un fin meramente ilustrativo. Consulte el correspondiente manual de instrucciones del operario para obtener más información sobre el uso correcto de esta maquinaria. No respetar el manual del operario al utilizar la maquinaria o actuar de forma irresponsable puede provocar lesiones graves e incluso mortales. La única garantía aplicable a nuestra maquinaria es la garantía escrita estándar de cada producto y venta. Terex no amplía dicha garantía de forma expresa ni implícita. Los productos y servicios mencionados pueden ser marcas comerciales, marcas de servicio o nombres de marca de Terex Corporation o de alguna de sus filiales en Estados Unidos y otros países. Todos los derechos reservados. Terex, el diseño de la corona Terex y Works For You son marcas registradas de Terex Corporation o de sus filiales.

Dezembro 2019. Especificações e preços dos produtos sujeitos a alteração sem aviso prévio ou obrigações. As fotografias e/ou desenhos neste documento são apenas para fins ilustrativos. Consulte o respectivo Manual do Operador para instruções sobre o uso correto deste equipamento. Deixar de acompanhar o respectivo Manual do Operador ao usar o nosso equipamento ou, por qualquer outra forma, deixar de agir de maneira responsável pode resultar em lesões corporais graves ou a morte. A única garantia aplicável ao nosso equipamento é a garantia padrão por escrito correspondente ao produto específico vendido. A Terex não dá outras garantias, expressas ou implícitas. Os produtos e serviços listados podem ser marcas comerciais, marcas de serviço ou nomes-fantasia da Terex Corporation e/ou suas subsidiárias nos EUA e em outros países. Todos os direitos reservados. Terex, o desenho da Coroa Terex e a expressão Works For You são marcas comerciais da Terex Corporation ou suas subsidiárias.

декабрь 2019 г. года Технические характеристики и цены могут изменяться без предварительного уведомления и без каких-либо обязательств для производителя. Фотографии и (или) чертежи в настоящем документе служат только в качестве иллюстраций. Инструкции по надлежащей эксплуатации данного оборудования см. в соответствующем руководстве для оператора. Невыполнение указаний соответствующих руководств для оператора при эксплуатации оборудования или другие безответственные действия могут повлечь серьезные травмы или смерть. Единственной гарантией, действующей в отношении нашего оборудования, является стандартная форма письменной гарантии на данный тип оборудования и на условия его продажи. Terex не дает никаких других гарантий: ни ясно выраженных, ни подразумеваемых. Перечисленные продукты и услуги могут быть торговыми марками, знаками обслуживания или торговыми наименованиями Terex Corporation и / или ее дочерних компаний в США и других странах. Все права защищены. Terex, изображение короны Terex и Works for You являются торговыми марками, принадлежащими корпорации Terex или ее дочерним компаниям.



[www.terex.com/cranes](http://www.terex.com/cranes)

Brochure Reference: TC-DS-M-E/II/G/F/S/P/R-CTT561A-20-12/19



**WORKS FOR YOU.™**