

DRAW WIRE SENSOR

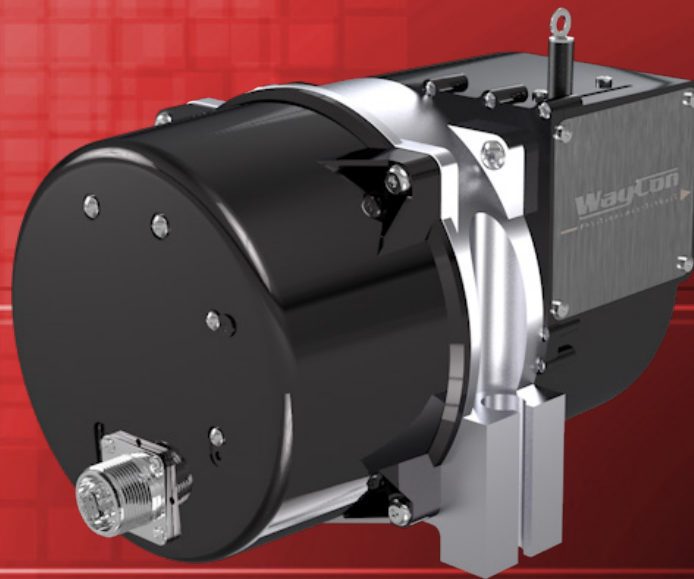

Series HX

Key-Features:

- Measurement ranges 50 mm up to 50.8 m
- Distance measurement and Tachometer
- Intrinsically safe model (UL, CSA certified)
- Linearity up to $\pm 0.1\%$
- Output: Analog, TTL or speed
- 2 designs, depending on the full scale
- Easy installation
- Stainless steel wire
- Operating temperature max. $-40...+95\text{ }^{\circ}\text{C}$
- Protection class IP68

Content:

Technical Data2
Description HX-EP3
Description HX-V and HX-VP3
Technical Drawing4
Electrical Connection5
Options6
Order Code7

TECHNICAL DATA

		HX-PA	HX-P420	HX-P510	HX-EP	HX-V	HX-VP
Measurement range		50 mm up to 50.8 m (see Mechanical Data)					
Linearity	[%]	MR ≤150: ±0.25 MR 250...640: ±0.15 MR ≥750: ±0.1	MR ≤150: ±0.3 MR 250...640: ±0.2 MR ≥750: ±0.15		±0.03 (independent of measurement range)	within ±0.1 % of the output signal	MR ≤150: ±0.25 MR 250...640: ±0.15 MR ≥750: ±0.1
Repeatability	[%]	±0.015				-	±0.015
Resolution		theoretically infinite ¹⁾			see „Description HX-EP“	-	theoretically infinite ¹⁾
Output signal		1 kΩ ±10 %	4...20 mA	0...5 V, 0...10 V, ±5 V, ±10 V	TTL	speed ²⁾	speed ²⁾ + analog
Power supply		max. 30 V (AC, DC)	9...35 VDC	4.9...30 VDC	5 or 8...28 VDC	-	max. 25 V (AC, DC)
Protection class		IP65 / optional: IP68					
Humidity	[%]	100					
Operating temperature	[°C]	-40...+95		-40...+85	-20...+95	-40...+95	
Shock resistance		50 g, 0.1 ms max.					
Vibration resistance		15 g, 0.1 ms max.					

¹⁾ depending on the quality of the power supply

²⁾ see „Description HX-EP“

MECHANICAL DATA

Order code	Measurement range	Measurement range available for HX-...			Draw wire tension [N]	Draw wire diameter [mm]	Sensor weight [kg]	Housing	Lifespan (full cycles)
		PA, P420, P510	EP	V, VP					
2	50 mm	x		x	9.4	0.4	0.9		5,000,000
3	75 mm	x		x	6.7	0.4	0.9		5,000,000
4	100 mm	x		x	6.7	0.4	0.9		5,000,000
5	125 mm	x		x	5.3	0.4	0.9		5,000,000
6	150 mm	x		x	6.7	0.4	0.9		5,000,000
10	250 mm	x	x	x	9.4	0.4	0.9		500,000
15	390 mm	x		x	6.7	0.4	0.9		500,000
20	500 mm	x		x	6.7	0.4	0.9		500,000
25	640 mm	x	x	x	5.3	0.4	0.9		500,000
30	750 mm	x		x	6.7	0.4	0.9		250,000
40	1000 mm	x		x	6.7	0.4	0.9		250,000
50	1250 mm	x	x	x	5.3	0.4	0.9		250,000
60	1500 mm	x	x	x	6.7	0.4	0.9		250,000
80	2000 mm	x	x	x	5.8	0.4	0.9		250,000
100	2.5 m	x	x	x	10	0.6	3.1		250,000
120	3 m	x	x	x	10	0.6	3.1		250,000
150	3.8 m	x	x	x	10	0.6	3.1		250,000
200	5 m	x	x	x	10	0.6	3.1	250,000	
250	6.3 m	x	x	x	10	0.6	3.1	250,000	
300	7.5 m	x	x	x	10	0.6	3.1	250,000	
350	8.8 m	x	x	x	10	0.6	3.1	250,000	
400	10 m	x	x	x	10	0.6	3.1	250,000	
500	12.7 m	x	x	x	10	0.6	3.9	5,000,000 m	
600	15.2 m	x	x	x	10	0.6	3.9	5,000,000 m	
800	20.3 m	x	x	x	10	0.6	3.9	5,000,000 m	
1000	25.4 m	x	x	x	10	0.6	5.4	5,000,000 m	
1200	30.4 m	x	x	x	10	0.6	5.6	5,000,000 m	
1600	40.6 m	x	x	x	10	0.6	6.4	5,000,000 m	
1800	45.7 m	x	x	x	10	0.6	7.2	5,000,000 m	
2000	50.8 m	x	x	x	10	0.5	7.4	5,000,000 m	



DESCRIPTION HX-EP

Resolution

Utilising an incremental encoder as the sensor, the HX-EP series provides a two-channel square wave current sinking output signal in quadrature. The standard output is a single-ended TTL compatible square. The resolution values shown in the specifications table indicate resolution for times 1 counting mode where a count is registered for one up transition in A channel. With interface electronics capable of times 2 or times 4 counting mode, a true resolutional increase of 2 or 4 may be obtained.

The actual resolution of a HX-EP sensor differs from unit to unit because of tolerances associated with the wire rope diameter and the capstan upon which the wire rope winds. The nylon jacketed wire rope will have the effect of slightly reducing the resolution. Linearity and repeatability remain independent of resolution.

Order code		HX-EP-10-...	HX-EP-25-...	HX-EP-50-...	HX-EP-60-...	HX-EP-80-...	HX-EP-...
Measurement range	[mm]	250	640	1250	1500	2000	≥2500
Resolution ¹⁾	[Pulses/mm]	19.69	9.84		8.1	6.11	3.26
Resolution tolerance	[%]	±0.3			±0.2		

¹⁾ The resolution shown is a calculated number based on the capstan diameter, the rope wire diameter and the line count of the encoding device.

Output

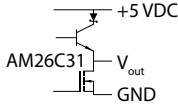
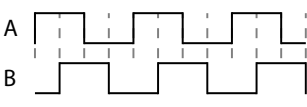
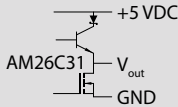
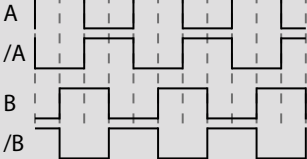
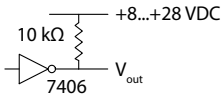
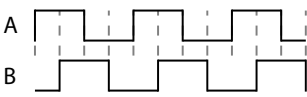
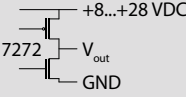
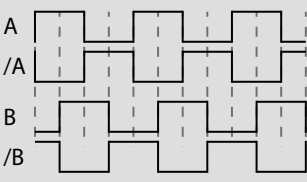
Option	Description	Output stage	Waveform	Pin assignment												
10	TTL compatible, Open Collector, current sinking Power supply: 5 VDC Signals: A, B			<table border="1"> <tr><td>+V_{in}</td><td>A</td></tr> <tr><td>GND</td><td>B</td></tr> <tr><td>Signal A</td><td>C</td></tr> <tr><td>Signal B</td><td>D</td></tr> <tr><td></td><td>E</td></tr> <tr><td></td><td>F</td></tr> </table>	+V _{in}	A	GND	B	Signal A	C	Signal B	D		E		F
+V _{in}	A															
GND	B															
Signal A	C															
Signal B	D															
	E															
	F															
30	Push-Pull differential Line Driver current sinking and current sourcing, compliant with the requirements of TIA/EIA-422-B Power supply: 5 VDC Signals: A, /A, B, /B			<table border="1"> <tr><td>+V_{in}</td><td>A</td></tr> <tr><td>GND</td><td>B</td></tr> <tr><td>Signal A</td><td>C</td></tr> <tr><td>Signal /A</td><td>D</td></tr> <tr><td>Signal B</td><td>E</td></tr> <tr><td>Signal /B</td><td>F</td></tr> </table>	+V _{in}	A	GND	B	Signal A	C	Signal /A	D	Signal B	E	Signal /B	F
+V _{in}	A															
GND	B															
Signal A	C															
Signal /A	D															
Signal B	E															
Signal /B	F															
50	current sinking output with internal pullup resistors 10 kΩ Power supply: 8...28 VDC Signals: A, B			<table border="1"> <tr><td>+V_{in}</td><td>A</td></tr> <tr><td>GND</td><td>B</td></tr> <tr><td>Signal A</td><td>C</td></tr> <tr><td>Signal B</td><td>D</td></tr> <tr><td></td><td>E</td></tr> <tr><td></td><td>F</td></tr> </table>	+V _{in}	A	GND	B	Signal A	C	Signal B	D		E		F
+V _{in}	A															
GND	B															
Signal A	C															
Signal B	D															
	E															
	F															
70	Push-Pull differential Line Driver current sinking and current sourcing Power supply: 8...28 VDC Signals: A, /A, B, /B			<table border="1"> <tr><td>+V_{in}</td><td>A</td></tr> <tr><td>GND</td><td>B</td></tr> <tr><td>Signal A</td><td>C</td></tr> <tr><td>Signal /A</td><td>D</td></tr> <tr><td>Signal B</td><td>E</td></tr> <tr><td>Signal /B</td><td>F</td></tr> </table>	+V _{in}	A	GND	B	Signal A	C	Signal /A	D	Signal B	E	Signal /B	F
+V _{in}	A															
GND	B															
Signal A	C															
Signal /A	D															
Signal B	E															
Signal /B	F															

DESCRIPTION HX-V AND HX-VP

The HX-V series linear speed (velocity) sensor incorporates a self-generating tachometer which eliminates the need for any external power supply. Extra-long brush life, excellent stability and a wide operating temperature range make the V series sensors highly reliable for long time service.

Measurement range	[mm]	50 / 250	75 / 390 / 750	100 / 500 / 1000	125 / 640 / 1250	150 / 1500	2000	≥2500
Speed output	[mV/cm/s]	78	53	40	32	27	20	71

TECHNICAL DRAWING

Measurement ranges up to 2 m

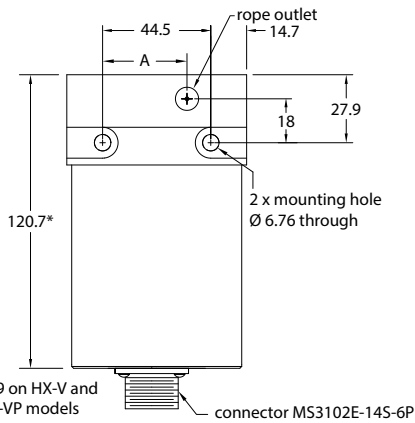
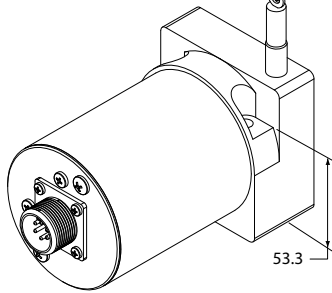

Measurement range [mm]	A [mm]
50 / 250	30.7
75 / 390 / 750	34.8
100 / 500 / 1000	38.9
125 / 640 / 1250	42.9
1500	46.7
2000	52.8

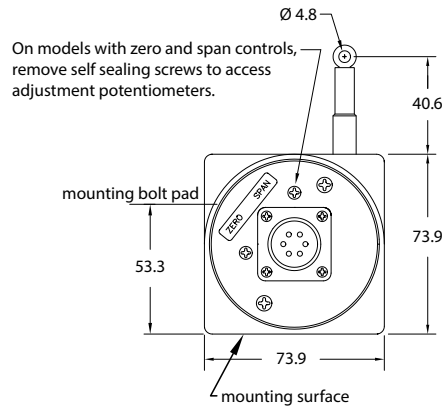

Note: Sensor mounts with M6 cylinder head screws.

Measurement ranges greater than 2 m

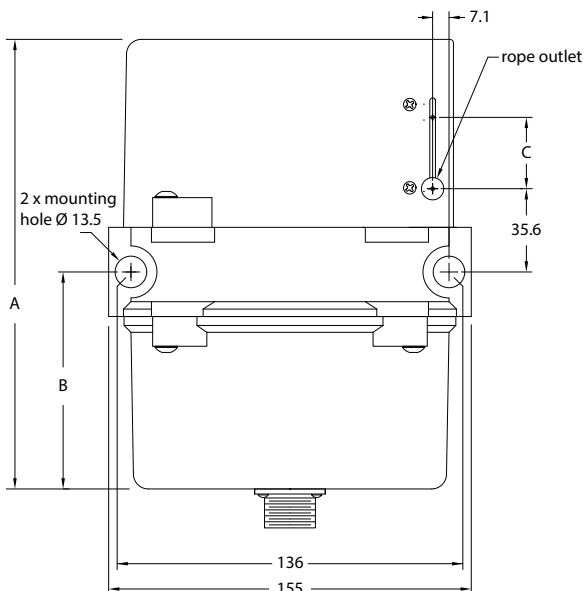
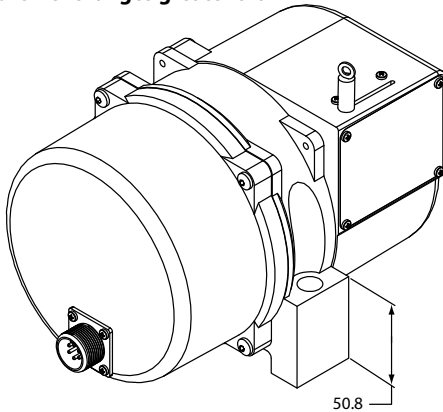

Measurement range [m]	A [mm]	B [mm]
≤20.3	196	97
≥25.4	280	142

Dimension "C" is the cable offset that occurs as the cable is extended from the transducer.
 $C = 0.0016 \text{ mm} \times E$, where E = extension in mm.

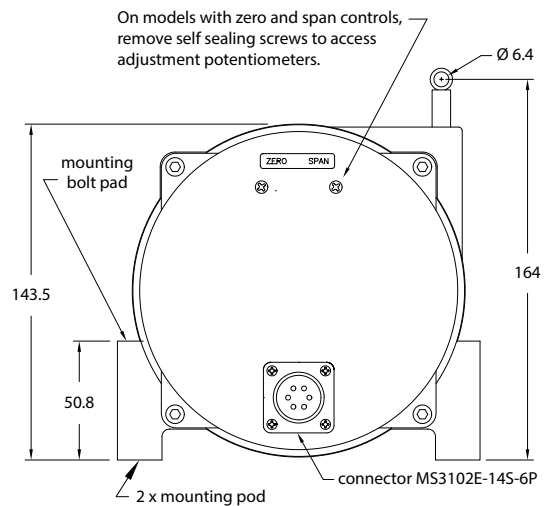

Note: Sensor mounts with M12 cylinder head screws.

ELECTRICAL CONNECTION

HX-PA

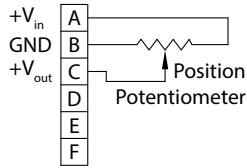

HX-P510

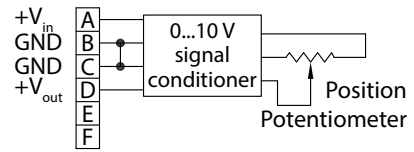

HX-P420

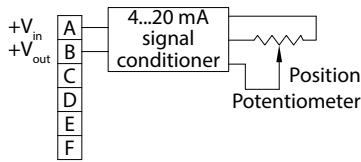

load resistance / input voltage

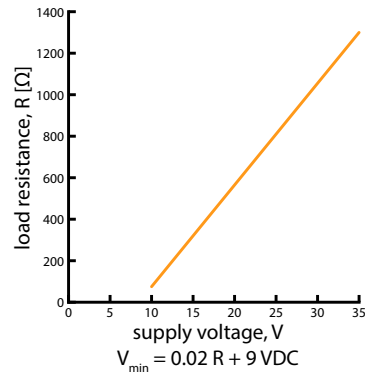

HX-V

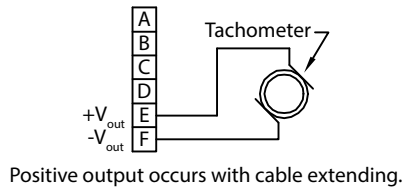

HX-VP

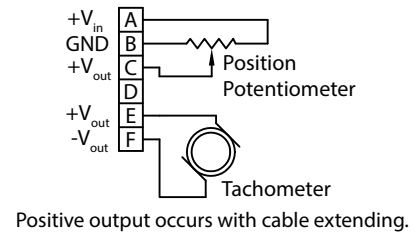

WARNING NOTICES

- Don't let the rope snap back. If the rope is retracted freely, this may lead to injuries (whiplash effect) and the device may be damaged. Caution when unhooking and retracting the rope into the sensor.
- Never exceed the specified measurement range when extracting the rope!
- Do not try to open the device. The stored energy of the spring drive may lead to injuries when being mishandled.
- Do not touch the rope when operating the sensor.
- Avoid guiding the rope over edges or corners. Use a deflection pulley instead.
- Do not operate the sensor if the rope is buckled or damaged. A ripping of the rope may lead to injuries or a damaging of the sensor.

OPTIONS

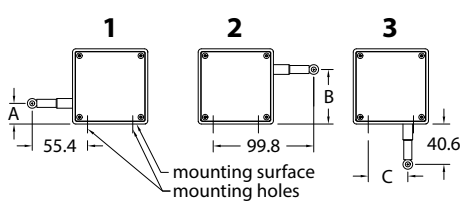
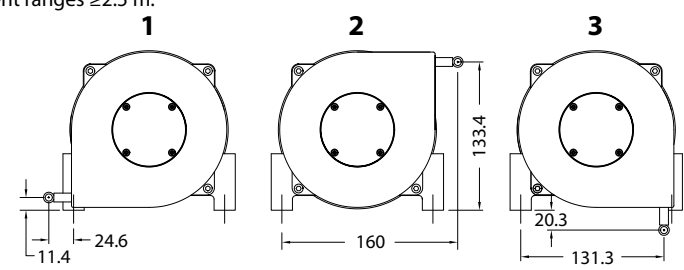
Option	Order code	Description																												
Nylon jacketed draw wire (measurement ranges ≤ 2 m)	N	Replaces standard stainless steel wire rope with $\varnothing 0.46$ mm nylon jacketed wire rope. This option increases wire life dramatically but may increase non-linearity by as much as $\pm 0.05\%$ of full scale.																												
Nylon jacketed draw wire (measurement ranges 2.5...12.7 m)	J	Replaces standard stainless steel wire rope with $\varnothing 0.94$ mm nylon jacketed wire rope. This option increases wire life dramatically but may increase non-linearity by as much as $\pm 0.05\%$ of full scale.																												
Inverted output signal	R	Output is at maximum when wire rope is fully retracted. Output decreases as wire rope is extended. (Does not apply to speed signal)																												
Protection class IP68 (only cable output)	2	Connector is replaced with a bulkhead fitting and a designated length of urethane jacketed, shielded twisted pair cable. Retraction mechanism and electrical components are sealed according to IP68.																												
Increased corrosion protection + IP68 (only cable output)	3	All external anodised aluminium parts of sensor are replaced with stainless steel and corrosion resistant plastic. Sensor is sealed according to IP68. Urethane jacketed, shielded twisted pair cable exits unit.																												
Different potentiometer resistance (MR ≥ 250 mm, HX-PA and HX-VPA only)	3, 4	3 = 5 k Ω 4 = 10 k Ω This option changes linearity as followed: Measurement ranges ≤ 640 mm = $\pm 0.5\%$ Measurement ranges ≥ 750 mm = $\pm 0.25\%$																												
Changed rope outlet	1, 2, 3	<p>Measurement ranges ≤ 2 m:</p>  <table border="1"> <thead> <tr> <th>Measurement range [mm]</th> <th>A [mm]</th> <th>B [mm]</th> <th>C [mm]</th> </tr> </thead> <tbody> <tr> <td>50 / 250</td> <td>28.4</td> <td>45.5</td> <td>30.7</td> </tr> <tr> <td>75 / 390 / 750</td> <td>24.4</td> <td>49.5</td> <td>34.8</td> </tr> <tr> <td>100 / 500 / 1000</td> <td>20.3</td> <td>53.6</td> <td>38.9</td> </tr> <tr> <td>125 / 640 / 1250</td> <td>16.3</td> <td>57.7</td> <td>42.9</td> </tr> <tr> <td>150 / 1500</td> <td>12.4</td> <td>61.5</td> <td>46.7</td> </tr> <tr> <td>2000</td> <td>6.4</td> <td>67.6</td> <td>52.8</td> </tr> </tbody> </table> <p>Measurement ranges ≥ 2.5 m:</p> 	Measurement range [mm]	A [mm]	B [mm]	C [mm]	50 / 250	28.4	45.5	30.7	75 / 390 / 750	24.4	49.5	34.8	100 / 500 / 1000	20.3	53.6	38.9	125 / 640 / 1250	16.3	57.7	42.9	150 / 1500	12.4	61.5	46.7	2000	6.4	67.6	52.8
Measurement range [mm]	A [mm]	B [mm]	C [mm]																											
50 / 250	28.4	45.5	30.7																											
75 / 390 / 750	24.4	49.5	34.8																											
100 / 500 / 1000	20.3	53.6	38.9																											
125 / 640 / 1250	16.3	57.7	42.9																											
150 / 1500	12.4	61.5	46.7																											
2000	6.4	67.6	52.8																											
Hazardous area protection (HX-P420 MR ≤ 20.3 m only)	X	UL, CSA intrinsically safe Class 1, Division 1, Groups A, B, C, D Class 2, Groups E, F, G Class III, hazardous locations																												

ORDER CODE HX-PA

HX-PA - [] - [] - [] - [] - N [] - [] - [] - []

Measurement range MR see „Mechanical Data“	[]
--	-----

Draw wire Standard stainless steel	S
Nylon jacketed (MR ≤ 2 m)	N
Nylon jacketed (MR 2.5...12.7 m)	J

Draw wire tension Standard	1
Reduced (MR ≤ 2 m)	2

Rope outlet Standard top	0
Left side	1
Right side	2
Bottom	3

Potentiometer resistance Standard 1 kΩ	1
5 kΩ (MR ≥ 250 mm)	3
10 kΩ (MR ≥ 250 mm)	4

Output signal Standard	S
Inverted	R

C	Connector type IP65 Connector with mating connector Con. without mating connector
K	
N	Connector type IP68 Cable with open ends Cable with connector at cable end
K	

B	Connection type IP65 Connector output, 6-polig
P	Connection type IP68 Cable output (0.3 m) Cable output (3 m) Cable output (4 m) Cable output (5 m) Cable output (6 m) Cable output (7 m)
3	
4	
5	
6	
7	

1	Housing option Standard IP65 IP68 Corrosion protection + IP68
2	
3	

ORDER CODE HX-P420

HX-P420 - [] - [] - [] - [] - 0 [] - [] - [] - []

Measurement range MR see „Mechanical Data“	[]
--	-----

Draw wire Standard stainless steel	S
Nylon jacketed (MR ≤ 2 m)	N
Nylon jacketed (MR 2.5...12.7 m)	J

Draw wire tension Standard	1
Reduced (MR ≤ 2 m)	2

Rope outlet Standard top	0
Left side	1
Right side	2
Bottom	3

Hazardous area protection without	N
UL, CSA intrin. safe (MR ≤ 20.3 m)	X

Output signal Standard	S
Inverted	R

C	Connector type IP65 Connector with mating connector Con. without mating connector
K	
N	Connector type IP68 Cable with open ends Cable with connector at cable end
K	

B	Connection type IP65 Connector output, 6-polig
P	Connection type IP68 Cable output (0.3 m) Cable output (3 m) Cable output (4 m) Cable output (5 m) Cable output (6 m) Cable output (7 m)
3	
4	
5	
6	
7	

1	Housing option Standard IP65 IP68 Corrosion protection + IP68
2	
3	

ORDER CODE HX-P510

HX-P510 - - - N -

Measurement range MR see „Mechanical Data“	
--	--

Draw wire Standard stainless steel	S
Nylon jacketed (MR ≤ 2 m)	N
Nylon jacketed (MR 2.5...12.7 m)	J

Draw wire tension Standard	1
Reduced (MR ≤ 2 m)	2

Rope outlet Standard top	0
Left side	1
Right side	2
Bottom	3

Output signal Standard	S
Inverted	R

C	Connector type IP65 Connector with mating connector Con. without mating connector
K	
N	Connector type IP68 Cable with open ends Cable with connector at cable end
K	

B	Connection type IP65 Connector output, 6-polig
P	Connection type IP68 Cable output (0,3 m) Cable output (3 m) Cable output (4 m) Cable output (5 m) Cable output (6 m) Cable output (7 m)
3	
4	
5	
6	
7	

1	Housing option Standard IP65 IP68 Corrosion protection + IP68
2	
3	

ORDER CODE HX-EP

HX-EP - - - N -

Measurement range MR see „Mechanical Data“	
--	--

Draw wire Standard stainless steel	S
Nylon jacketed (MR ≤ 2 m)	N
Nylon jacketed (MR 2.5...12.7 m)	J

Draw wire tension Standard	1
Reduced (MR ≤ 2 m)	2

Rope outlet Standard top	0
Left side	1
Right side	2
Bottom	3

Output signal 5 VDC TTL compatible	10
5 VDC Push-Pull Line Driver	30
8...28 VDC current sinking	50
8...28 VDC Push-Pull Line Driver	70

C	Connector type IP65 Connector with mating connector Con. without mating connector
K	
N	Connector type IP68 Cable with open ends Cable with connector at cable end
K	

B	Connection type IP65 Connector output, 6-polig
P	Connection type IP68 Cable output (0,3 m) Cable output (3 m) Cable output (4 m) Cable output (5 m) Cable output (6 m) Cable output (7 m)
3	
4	
5	
6	
7	

1	Housing option Standard IP65 IP68 Corrosion protection + IP68
2	
3	

ORDER CODE HX-V

HX-V - [] - [] - [] - [] - N O S - [] - [] - []

Measurement range MR see „Mechanical Data“	
--	--

Draw wire Standard stainless steel	S
Nylon jacketed (MR ≤ 2 m)	N
Nylon jacketed (MR 2.5...12.7 m)	J

Draw wire tension Standard	1
Reduced (MR ≤ 2 m)	2

Rope outlet Standard top	0
Left side	1
Right side	2
Bottom	3

C	Connector type IP65 Connector with mating connector Con. without mating connector
K	
N	Connector type IP68 Cable with open ends Cable with connector at cable end
K	

B	Connection type IP65 Connector output, 6-polig
P	Connection type IP68 Cable output (0.3 m) Cable output (3 m) Cable output (4 m) Cable output (5 m) Cable output (6 m) Cable output (7 m)
3	
4	
5	
6	
7	

	Housing option Standard IP65 IP68 Corrosion protection + IP68
1	
2	
3	

ORDER CODE HX-VP

HX-VP [] - [] - [] - [] - [] - N [] - [] - [] - []

Ausgangssignal Potentiometer	A
Brückenschaltung	B
Analogausgang 4...20 mA	420
Analogausgang 0...10V	510

Measurement range MR see „Mechanical Data“	
--	--

Draw wire Standard stainless steel	S
Nylon jacketed (MR ≤ 2 m)	N
Nylon jacketed (MR 2.5...12.7 m)	J

Draw wire tension Standard	1
Reduced (MR ≤ 2 m)	2

Rope outlet Standard top	0
Left side	1
Right side	2
Bottom	3

Potentiometer resistance Output signals B, 420 or 510	0
Standard 1 kΩ	1
5 kΩ (MR ≥ 250 mm)	3
10 kΩ (MR ≥ 250 mm)	4

C	Connector type IP65 Connector with mating connector Con. without mating connector
K	
N	Connector type IP68 Cable with open ends Cable with connector at cable end
K	

B	Connection type IP65 Connector output, 6-polig
P	Connection type IP68 Cable output (0.3 m) Cable output (3 m) Cable output (4 m) Cable output (5 m) Cable output (6 m) Cable output (7 m)
3	
4	
5	
6	
7	

	Housing option Standard IP65 IP68 Corrosion protection + IP68
1	
2	
3	

S	Output signal Standard Inverted
R	

ACCESSORIES

Connection cable for HX with IP65

10119-3M	3 m, with mating connector
10119-4M	4 m, with mating connector
10119-5M	5 m, with mating connector
10119-6M	6 m, with mating connector
10119-7M	7 m, with mating connector



Connection cable for HX with IP68 and connector type K

10424-3M	3 m, with mating connector
10424-4M	4 m, with mating connector
10424-5M	5 m, with mating connector
10424-6M	6 m, with mating connector
10424-7M	7 m, with mating connector

