

Encoders

Magnetic Encoders

Features:
 32, 64, 128, 256 Lines per revolution
 3 Channels
 Digital output

Series HEM3-256-W

		HEM3-256-W	
Signal output, square wave		3	channels
Supply voltage ¹⁾	V _{DD}	3,0 ... 3,6	V DC
Supply voltage ²⁾	V _{DD}	4,5 ... 5,5	V DC
Current consumption, typical (V _{DD} = 3,3 or 5 V DC)	I _{DD}	16	mA
Output current, max. ³⁾ (V _{DD} = 3,3 / 5 V DC)	I _{OUT}	2 / 4	mA
Pulse width	P	180 ± 45	°e
Phase shift, channel A to B	Φ	90 ± 45	°e
Logic state width	S	90 ± 45	°e
Signal rise/fall time, max (C _{LOAD} = 50 pF)	tr/tf	0,1 / 0,1	µs
Rotational speed up to	n _{max.}	30 000	rpm
Inertia of code disc	J	0,02	gcm ²
Operating temperature range		-30 ... +85	°C

- ¹⁾ V_{DD} = 3,3 V DC: Connect pins 3 and 4 to 3,3 V DC
- ²⁾ V_{DD} = 5 V DC: Connect pin 3 to 5 V DC, do not connect pin 4
- ³⁾ V_{DD} = 5 V DC: Low logic level < 0,5 V, high logic level > 4,5 V: CMOS and TTL compatible

Ordering information			
Encoder	number of channels	lines per revolution	for combination with:
HEM3-032-W	3	32	DC-Micromotors series 0816 ... S 1016 ... G, 1024 ... S 1224 ... SR
HEM3-064-W	3	64	
HEM3-128-W	3	128	
HEM3-256-W	3	256	

Note: Lines per revolution refers to pre-quadrature resolution and equals the cycles per revolution

Features

These incremental shaft encoders in combination with the FAULHABER DC-Micromotors are designed for indication and control of both shaft velocity and direction of rotation as well as for positioning.

Solid state sensors and a low inertia magnetic disc provide two channels with 90° phase shift and one index channel.

The nominal supply voltage for the encoder is selectable and either 3,3 VDC or 5,0 VDC.

The supply voltage for the encoder and the DC-Micromotor as well as the output signals are interfaced with discrete wires and an 8-pin Molex crimp style connector.

Details for the DC-Micromotors and suitable reduction gearheads are on separate catalog pages.

Output signals / Circuit diagram / Connector information

Output signals
with clockwise rotation as seen from the shaft end

Output circuit

Pin Function

- 1 Motor -
- 2 GND
- 3 V_{DD} 5V
- 4 V_{DD} 3,3V
- 5 Channel A
- 6 Channel B
- 7 Index
- 8 Motor +

Connector
Molex 51021-0800
grid 1,25 mm

DC-Micromotor 0816 N ... S - K1707 with Encoder HEM3-XXX-W

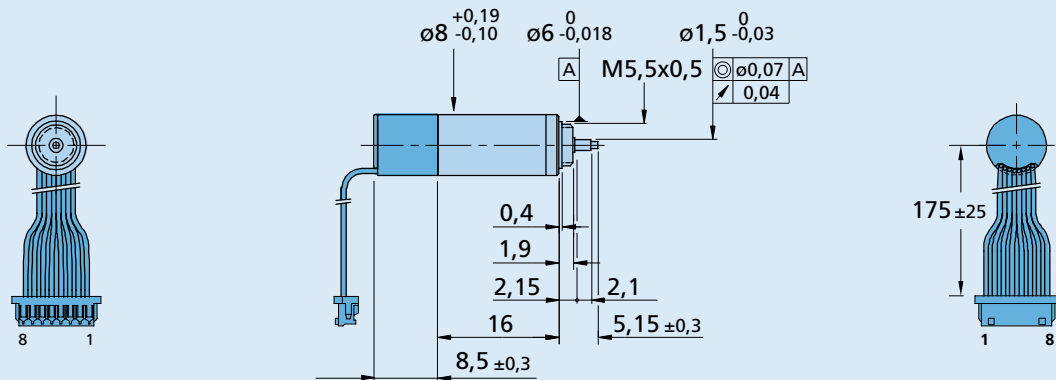

HEM3-XXX-W+0816N

DC-Micromotor 1016 N ... G - K1707 with Encoder HEM3-XXX-W

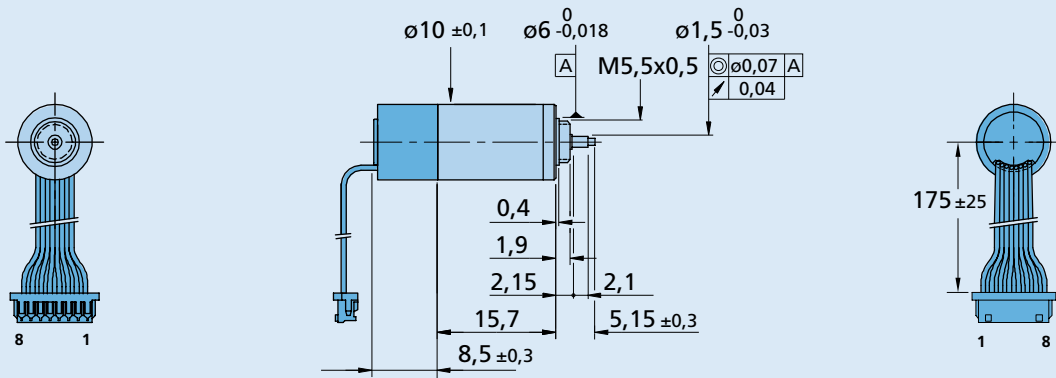

HEM3-XXX-W+1016N

DC-Micromotor 1024 N ... S - K1707 with Encoder HEM3-XXX-W

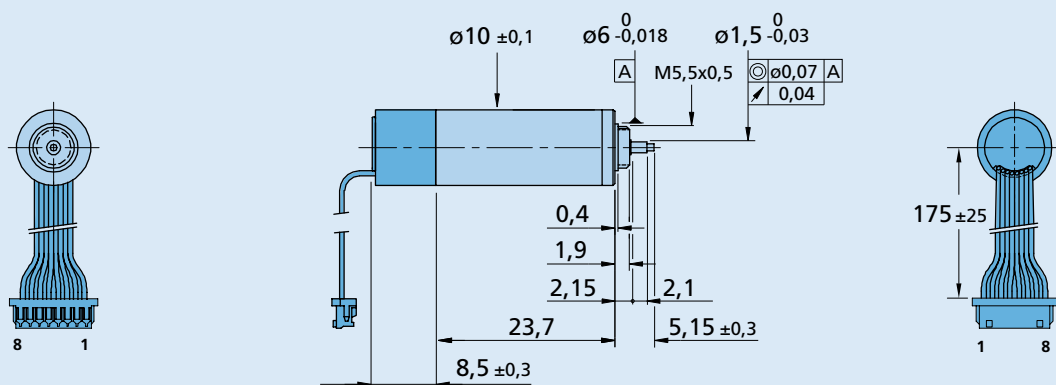

HEM3-XXX-W+1024N

DC-Micromotor 1224 N ... SR - K1707 with Encoder HEM3-XXX-W

