

# Timmo 4

## Aufbauanleitung

DE – Bevor Sie beginnen:

- Es ist empfehlenswert sich etwas Zeit zu nehmen, um die Aufbauanleitung zu lesen, bevor mit dem Aufbau begonnen wird.
- Der Aufbau sollte in der vorgegebenen Reihenfolge erfolgen.
- Die Aufbauanleitung dient lediglich als Richtschnur für den Aufbau. Nicht alle Schritte sind im Detail vorgegeben.
- Bitte prüfen Sie alle Teile auf Vollständigkeit und Zustand vor dem Aufbau.
- Der Aufbau sollte durch mindestens 2 Personen erfolgen.
- Bei starkem Wind sollte der Aufbau nicht erfolgen.
- Bohren Sie die Teile vor, wo es angezeigt wird.
- **Wichtiger Hinweis!** Wir empfehlen ausdrücklich das Gartenhaus vor der Behandlung mit Holzfarbe oder -lasur vollständig aufzubauen. Andernfalls kann es durch das einseitige Auftragen von Farbe/Lasur auf das trockene Holz zu einem Verziehen der Elemente kommen, die den Aufbau erschweren.

## Instructions d'assemblage

FR – Avant de commencer:

- Avant de commencer le processus d'assemblage, veuillez s'il vous plaît vous familiariser parfaitement avec les instructions.
- La maison doit être assemblée suivant la séquence indiquée dans les instructions.
- Les instructions s'entendent comme lignes directrices, toutes les étapes ne sont pas décrites en détails.
- Avant de commencer l'assemblage, vérifier tous les éléments.
- Deux personnes sont nécessaires au minimum pour l'assemblage.
- Ne pas tenter d'assembler la maison dans des conditions de vents forts.
- Percer les trous dans les éléments suivant les marques.

## Montage-instructie

NL – Alvorens te beginnen:

- Voordat u begint met de montage raden wij u aan de handleiding grondig door te lezen.
- Bij de montage van het huis dient u de volgorde zoals deze in de handleiding is aangegeven te volgen.
- De handleiding is bedoeld als richtsnoer, niet alle stappen zijn in detail uitgewerkt.
- Vóór de montage dienen alle details gecontroleerd te worden.
- De montage van het huis dient door tenminste twee personen uitgevoerd te worden.
- Het huis nooit in harde wind opbouwen.
- Gat in onderdelen boren, waar dit staat aangegeven.

## Pokyny k montáži

CZ – Než začnete:

- Než začnete s montáží, seznámte se důkladně s těmito pokyny.
- Domek musí být sestaven v pořadí uvedeném v pokynech.
- Pokyny slouží pouze jako vodítko, ne všechny kroky jsou zde popsány dopodrobna.
- Než začnete s montáží, zkontrolujte všechny díly.
- K montáži jsou zapotřebí minimálně dvě osoby.
- Nepokoušejte se smontovat domek za silného větru.
- Vyrvejte do dílů otvory podle značek.

## Pokyny pre montáž

SK – Predtým, než začnete:

- Predtým, než začnete montovať, sa, prosím, dôkladne oboznámte s týmito pokynmi.
- Dom je potrebné zmontovať podľa poradia uvedeného v pokynoch.
- Tieto pokyny poskytujú návod, nepopisujú však detailne všetky kroky.
- Predtým, než začnete montovať, skontrolujte všetky časti.
- Pri montáži sú potrební najmenej dvaja ľudia.
- Nepokúšajte sa montovať dom pri silnom vetre.
- Otvory v jednotlivých častiach vyrvajte podľa označenia.

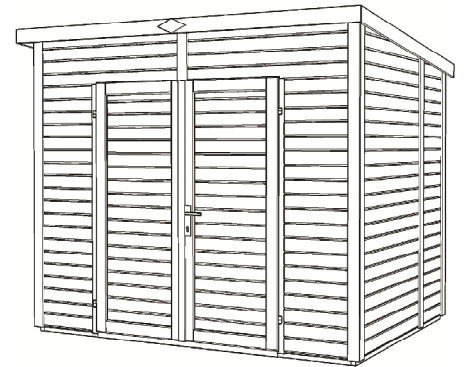

A)

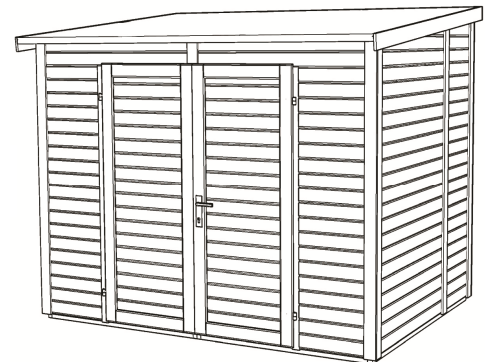

B)

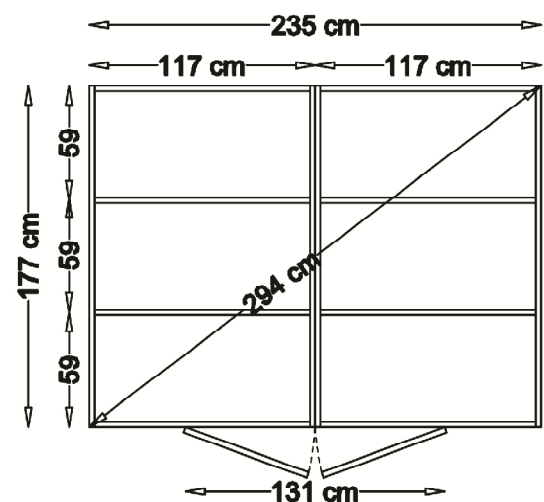

BALTIC Garden Products

Produced by:  
Baltic Connexions OÜ  
Tabivere 49127, Jõgevamaa  
Esiand  
service@balcon.ee



FSC  
www.fsc.org

MIX

Wood from  
responsible sources

FSC® C010796

# Timmo 4

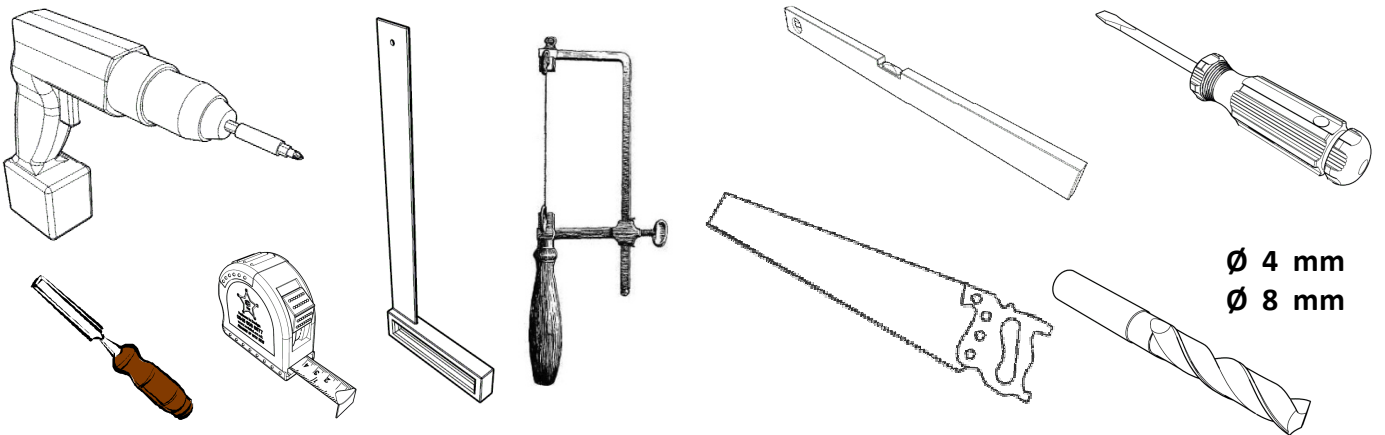

1.	2 x F	117 x 177 cm
2.	4 x W1	117 x 170 cm
3.	2 x W2	54 x 170 cm
4.	1 x W3	50 x 170 cm
5.	1 x W4	50 x 170 cm
6.	1 x GL	36 x 117 cm
7.	1 x GR	36 x 117 cm
8.	1 x NL	19 x 117 cm
9.	1 x NR	19 x 117 cm
10.	1 x A1	36 x 117 cm
11.	1 x A2	36 x 117 cm
12.	2 x RG	2,8 x 8 x 177 cm
13.	3 x K1	1 x 83 x 115 cm
14.	3 x K2	1 x 83 x 83 cm
15.	1 x D1	67 x 168 cm
16.	1 x D2	67 x 168 cm
17.	2 x T1	100 x 260 cm
18.	1 x T2	50 x 260 cm
19.	4 x OP	2,8 x 2,8 x 124 cm
20.	4 x OT	2,8 x 2,8 x 96 cm
21.	2 x B1	1,2 x 9 x 126 cm
22.	4 x B2	1,2 x 9 x 99 cm
23.	4 x C2	1,9 x 4,5 x 168 cm
24.	2 x C3	1,9 x 4,5 x 36 cm
25.	2 x C5	1,9 x 4,5 x 18 cm
26.	11 x C1	1,2 x 7 x 168 cm
27.	7 x C4	1,2 x 7 x 36 cm
28.	5 x C6	1,2 x 7 x 18 cm
29.	1 x S1	1,9 x 4,5 x 80 cm
30.	2 x S2	1,9 x 4,5 x 71 cm
31.	1 x KS	1,9 x 4,5 x 133 cm
32.	1 x DC	1,2 x 4,2 x 168 cm
33.	1 x HH	2,8 x 2,8 x 147 cm
34.	1 x FI	1,2 x 9 x 20 cm
35.	1 x UK	
36.	2 x LB	
37.	1 x SS	
38.	2 x UL	
39.	1 x UH	
		Menge
40.	50 mm Schrauben	78
41.	35 mm Schrauben	166
42.	25 mm Schrauben	18
43.	40 mm Nägel	24
44.	10 mm Nägel	156

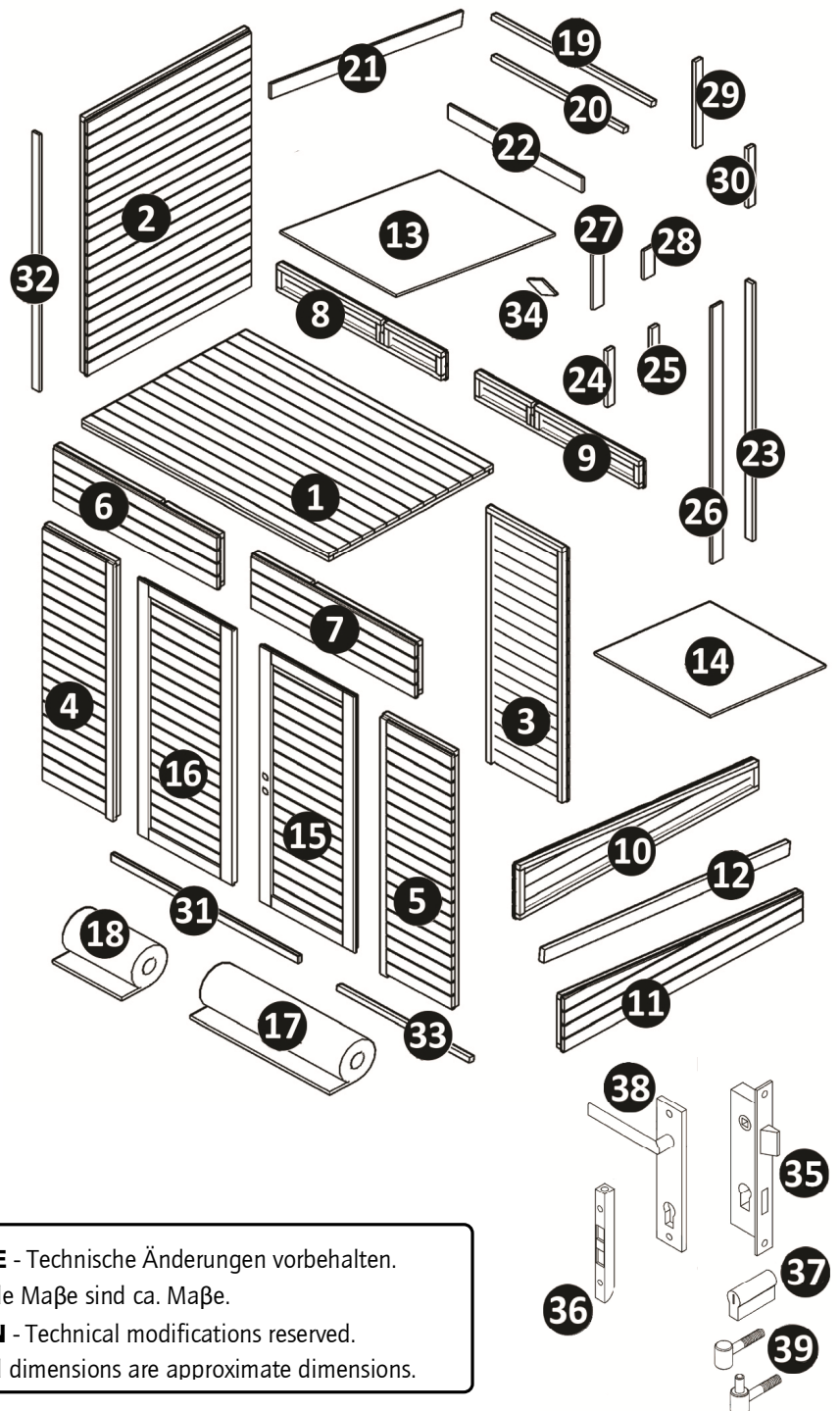

**DE** - Technische Änderungen vorbehalten.  
Alle Maße sind ca. Maße.

**EN** - Technical modifications reserved.  
All dimensions are approximate dimensions.



# Timmo 4

1.

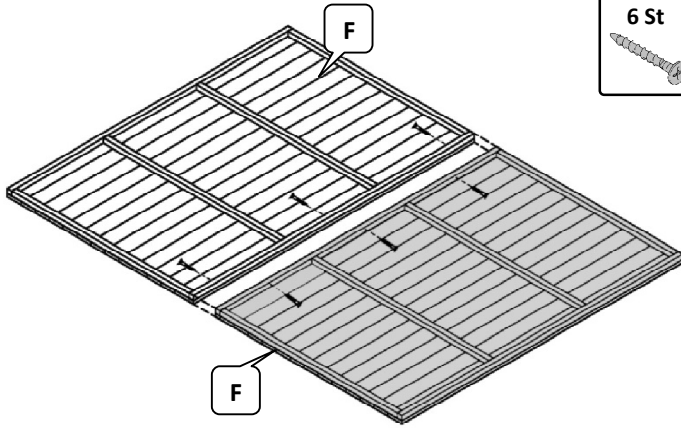

4 mm



50 mm  
6 St



2.

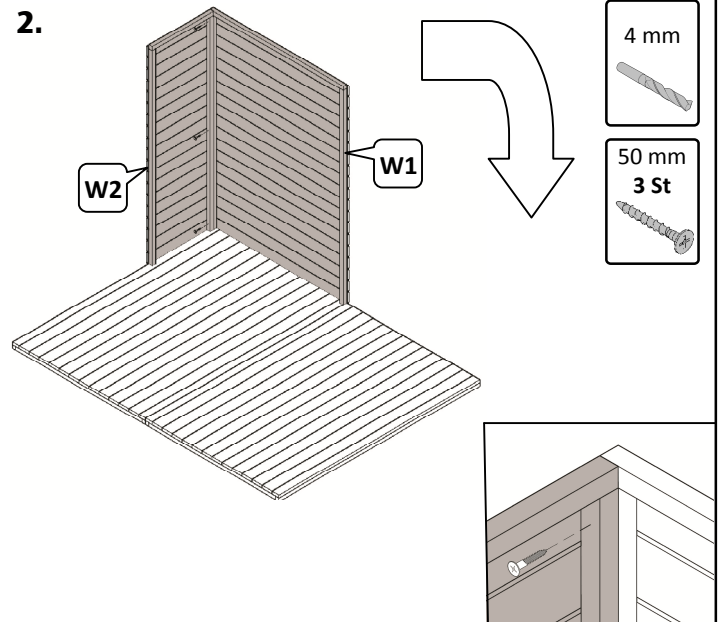

4 mm



50 mm  
3 St



3.

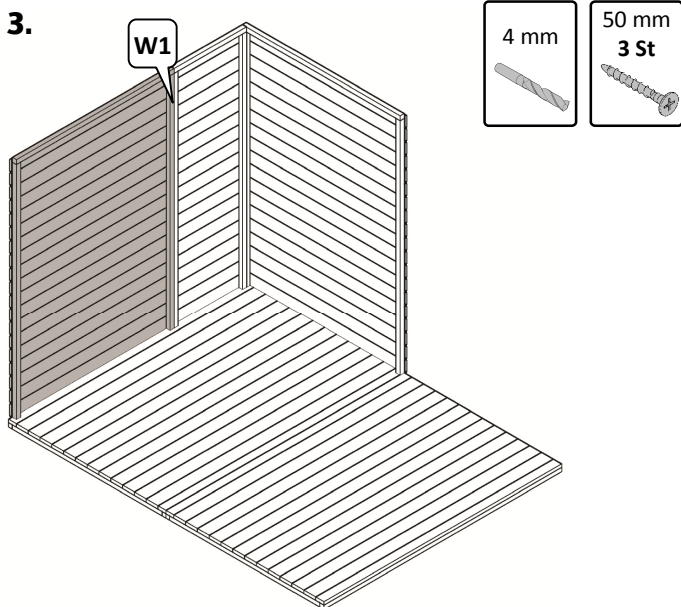

4 mm



50 mm  
3 St



4.

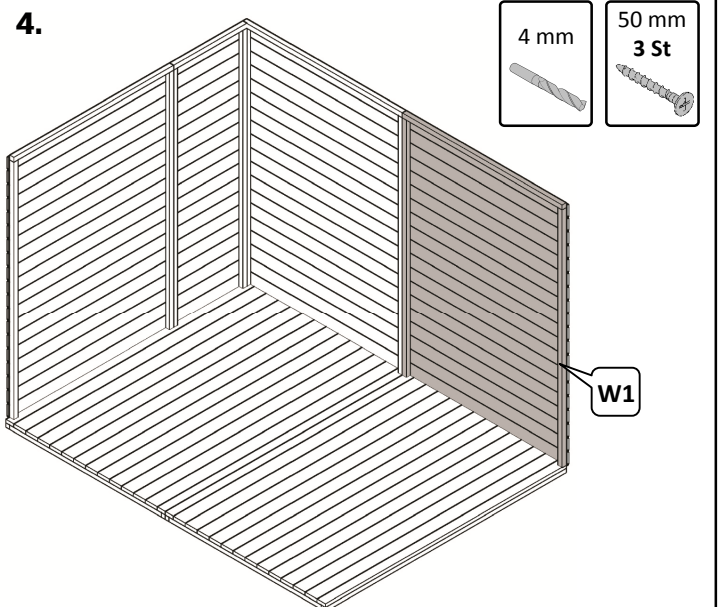

4 mm



50 mm  
3 St



5.

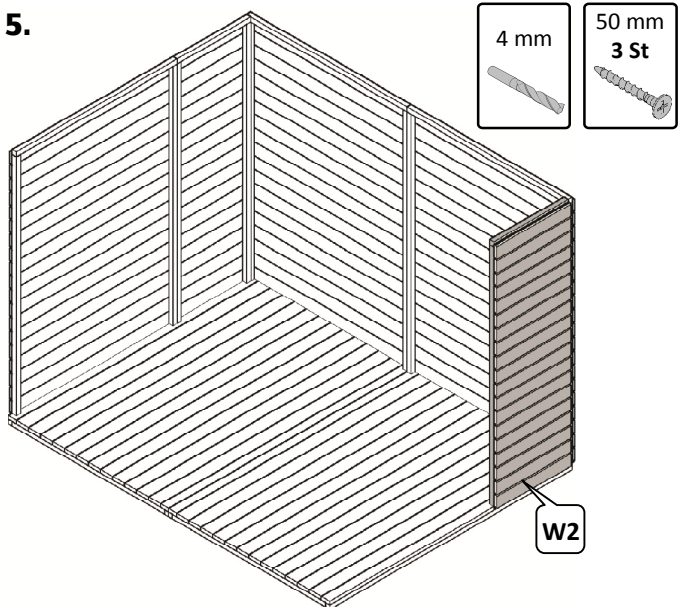

4 mm



50 mm  
3 St



6.

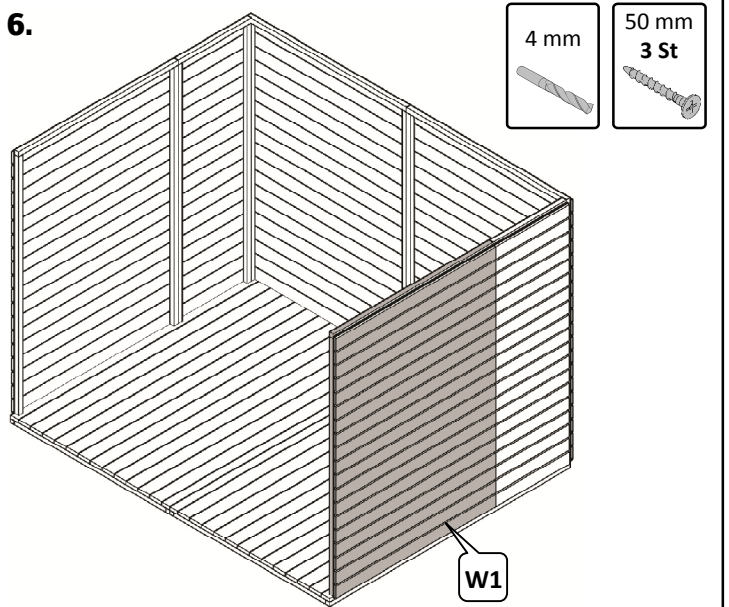

4 mm



50 mm  
3 St



# Timmo 4

7.

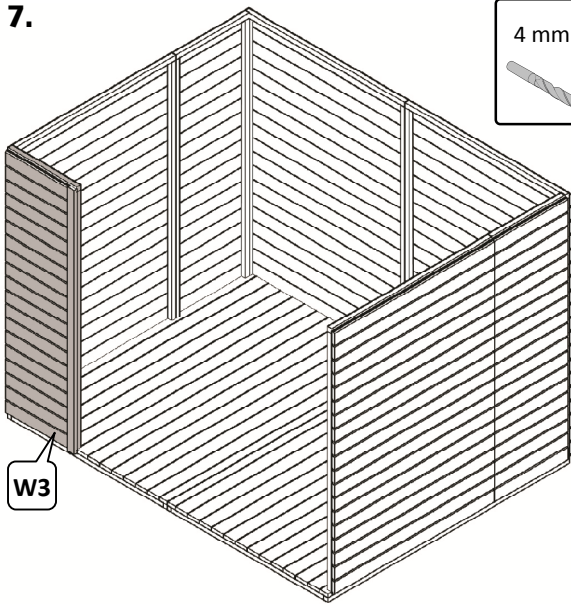

4 mm

50 mm  
3 St

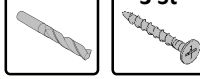

8.

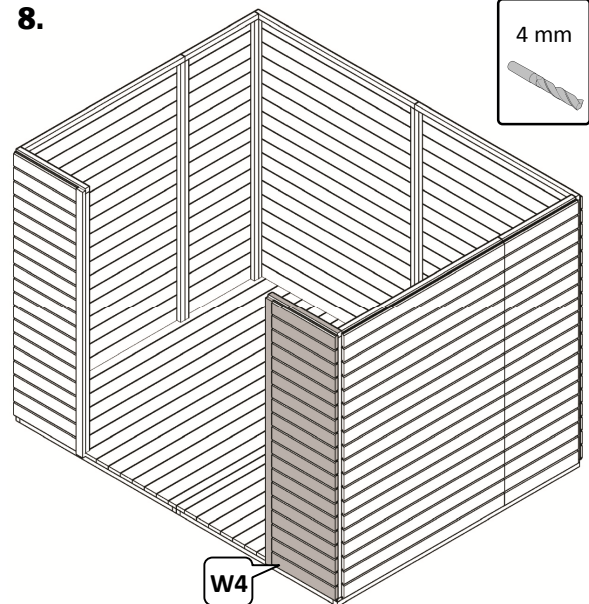

4 mm

50 mm  
3 St

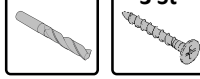

9.

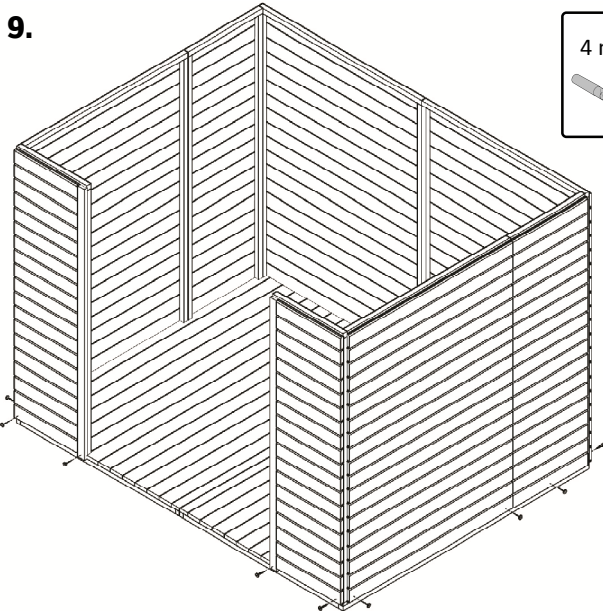

4 mm

50 mm  
14 St

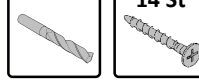

W1,2,3,4

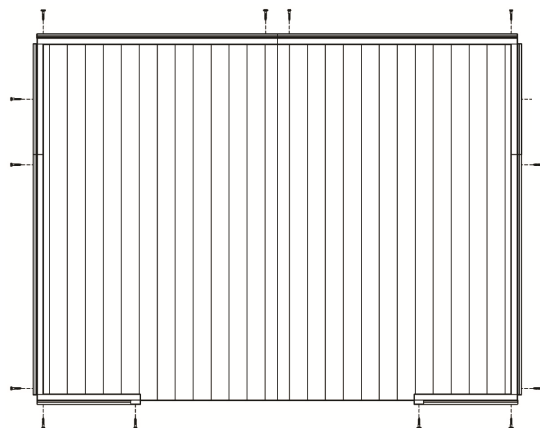

10. A

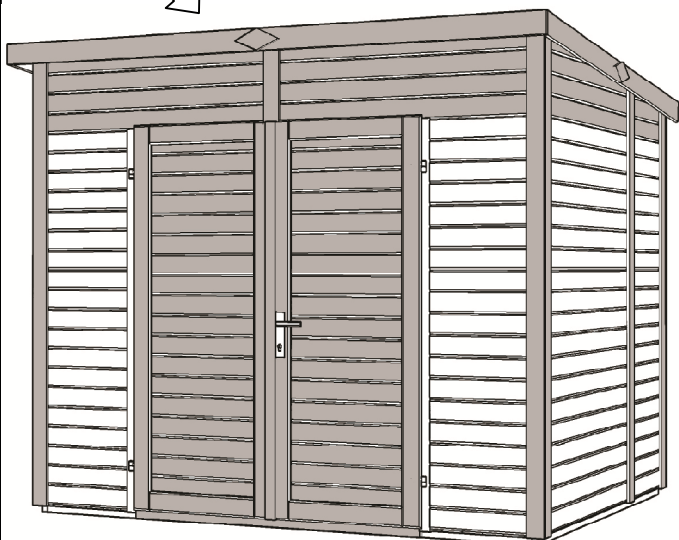

11. A

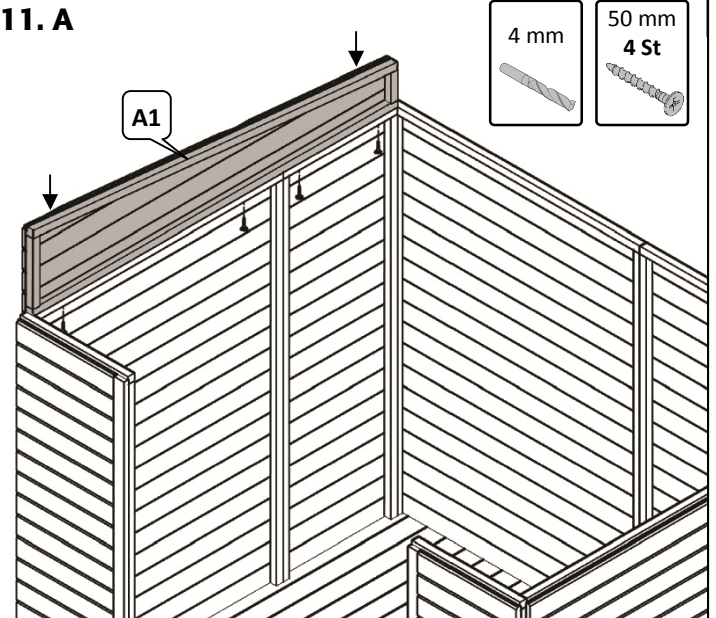

4 mm

50 mm  
4 St

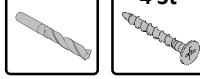

A1



# Timmo 4

12. A

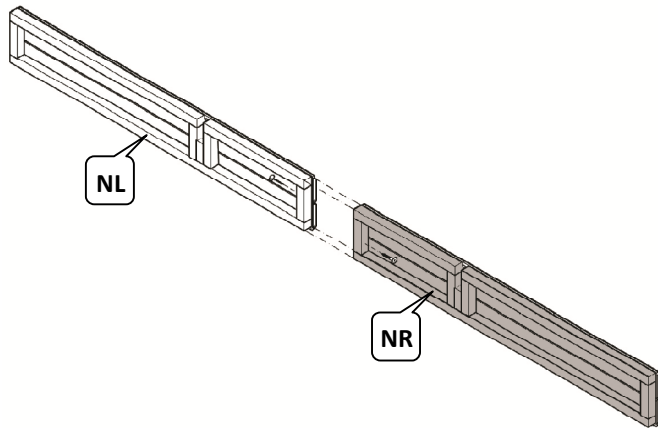
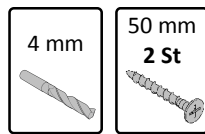

13. A

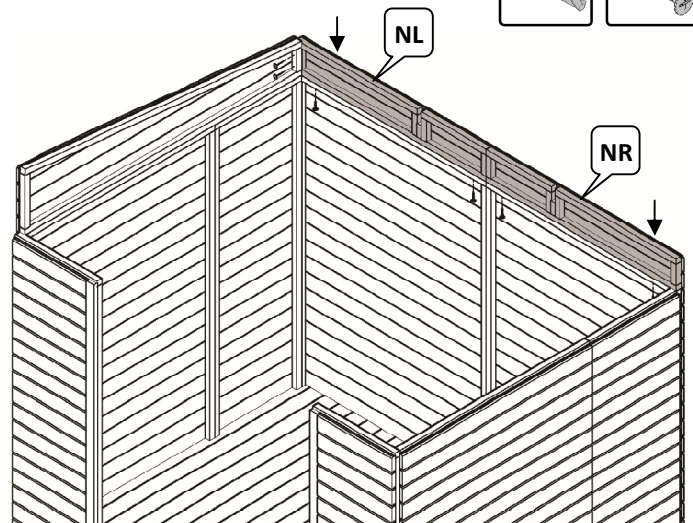
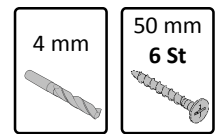

13.1 A

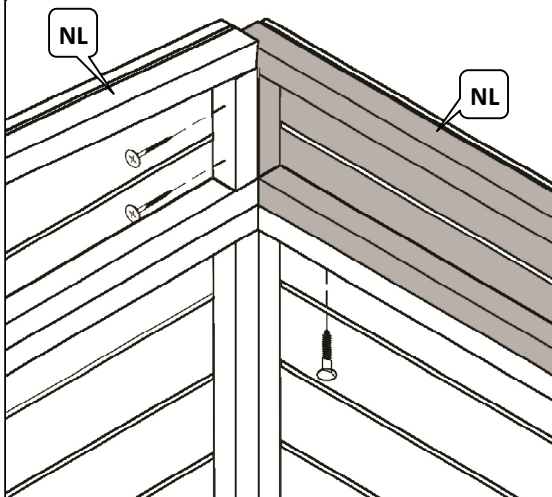

14. A

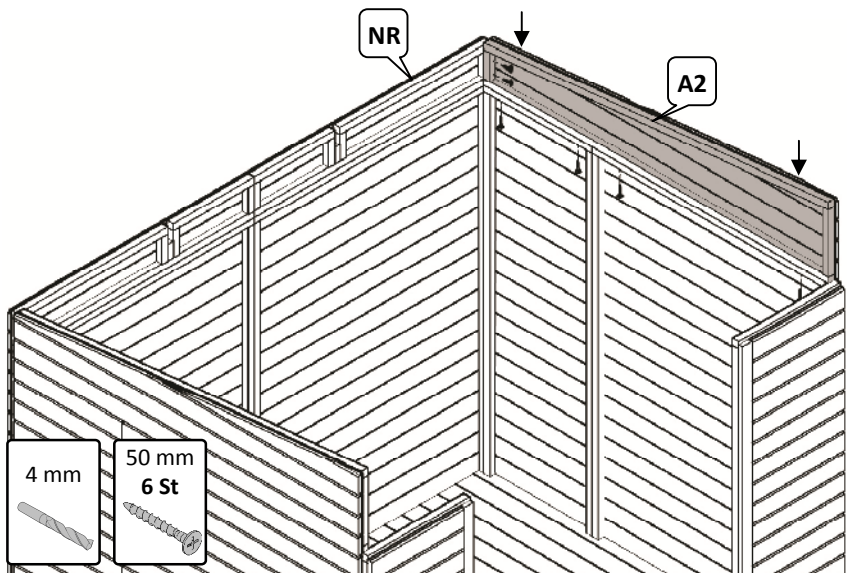

14.1 A

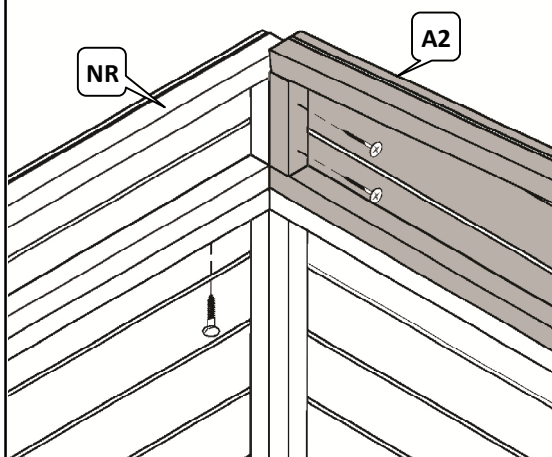

15. A

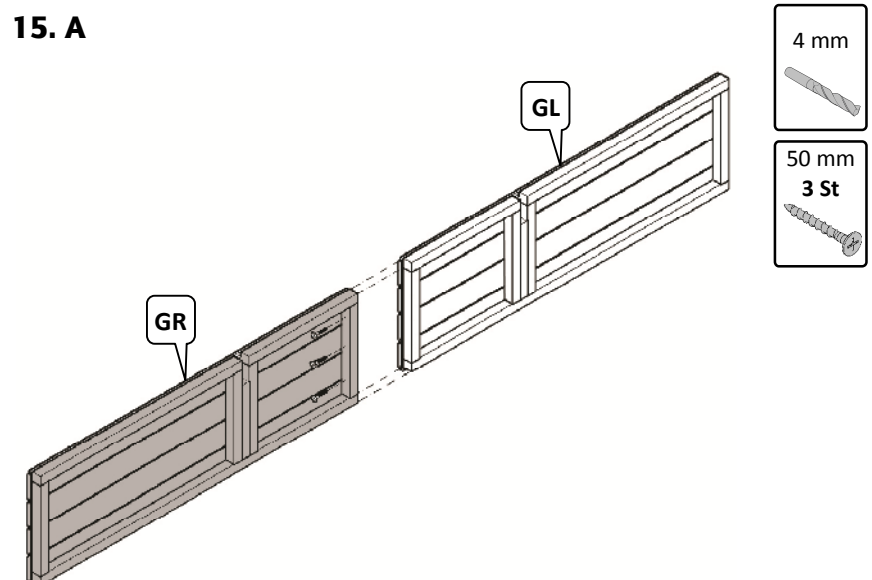

# Timmo 4

16. A

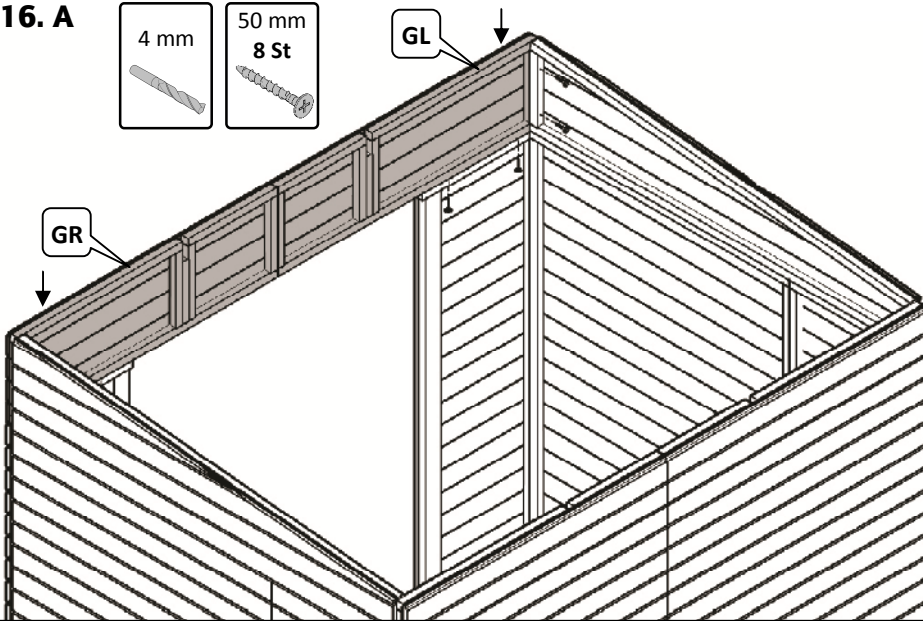
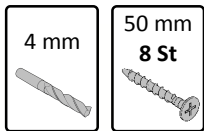

16.1 A

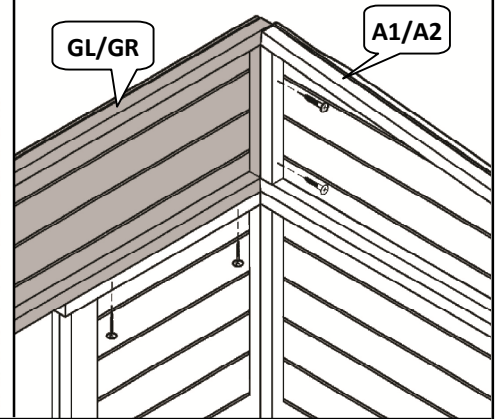

17. A

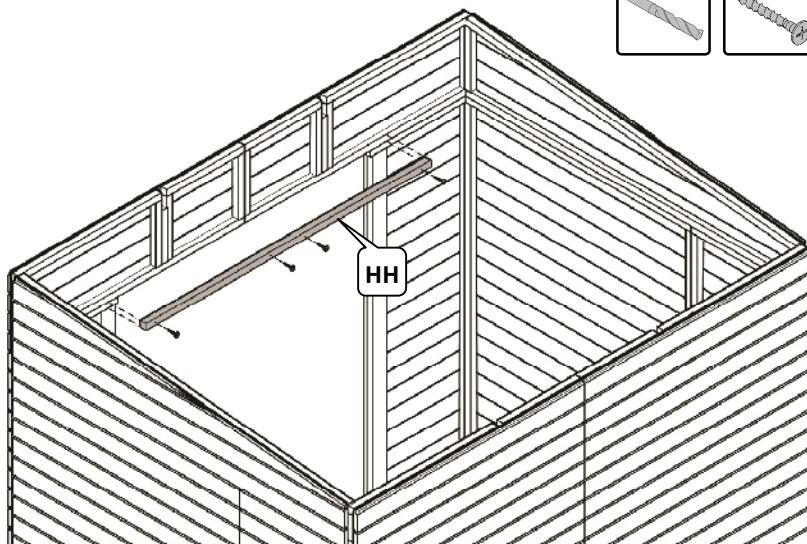
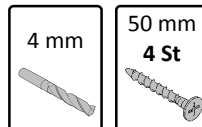

10. B

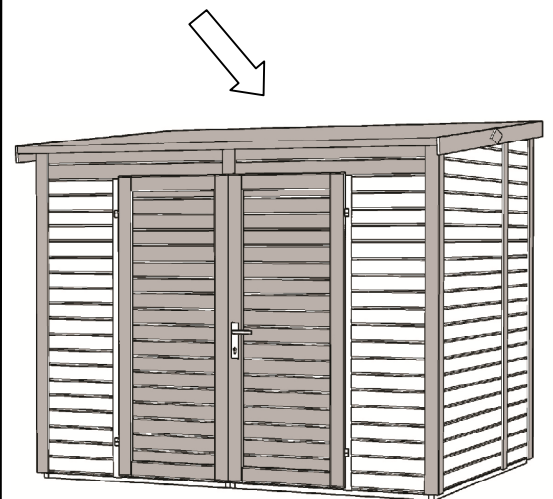

11. B

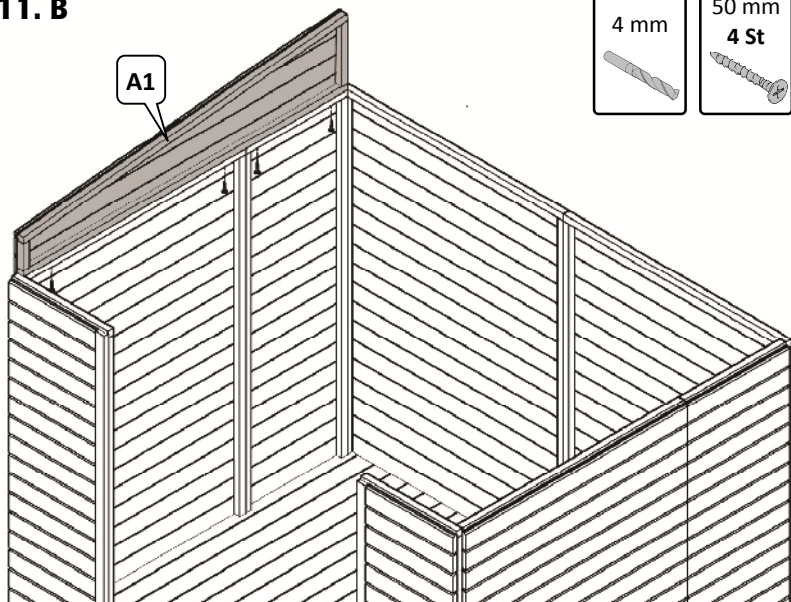
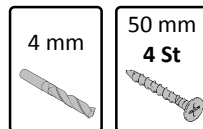

12. B

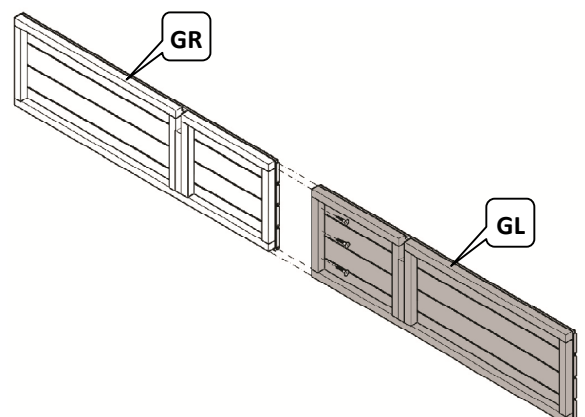
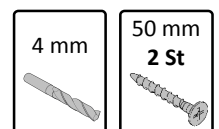



# Timmo 4

13. B

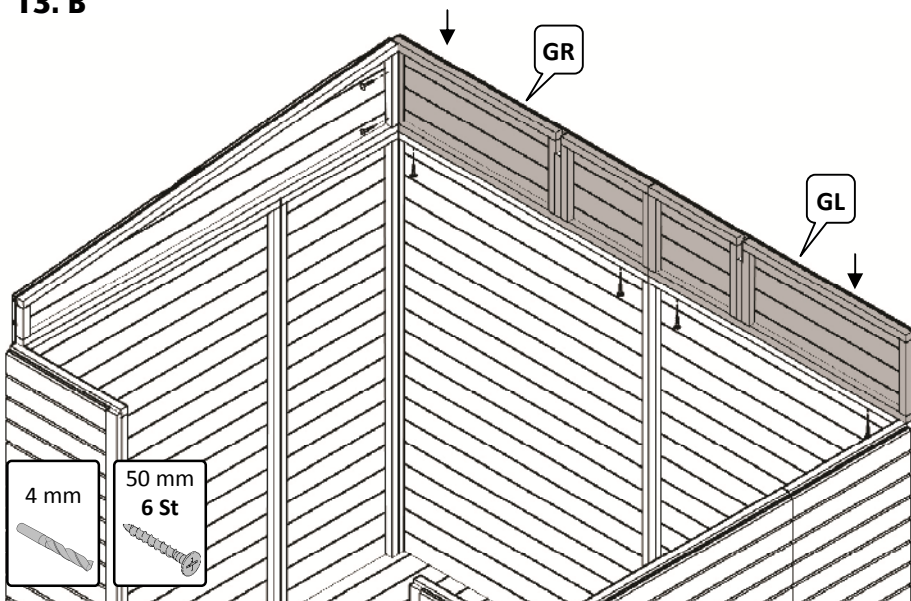

13.1 B

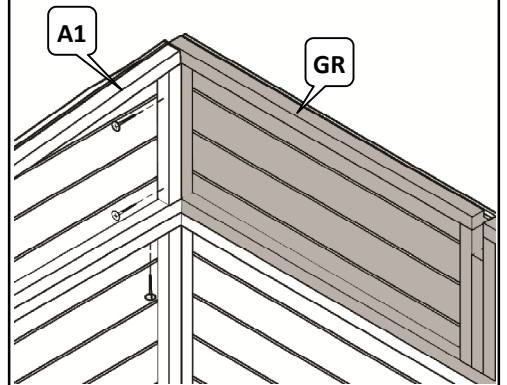

14. B

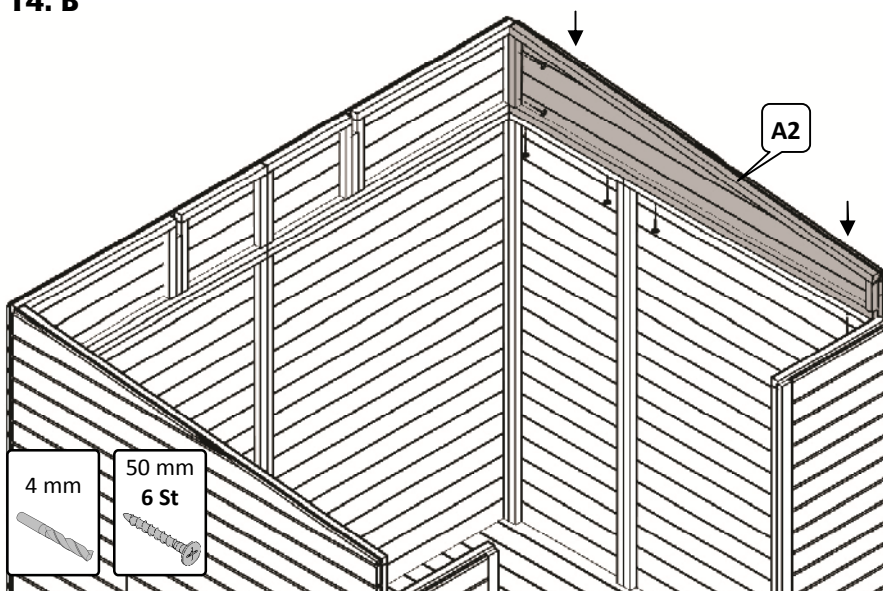

14.1 B

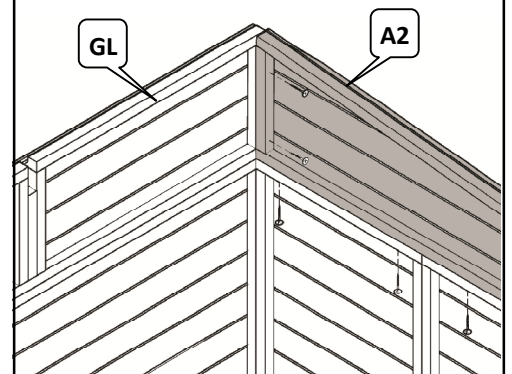

15. B

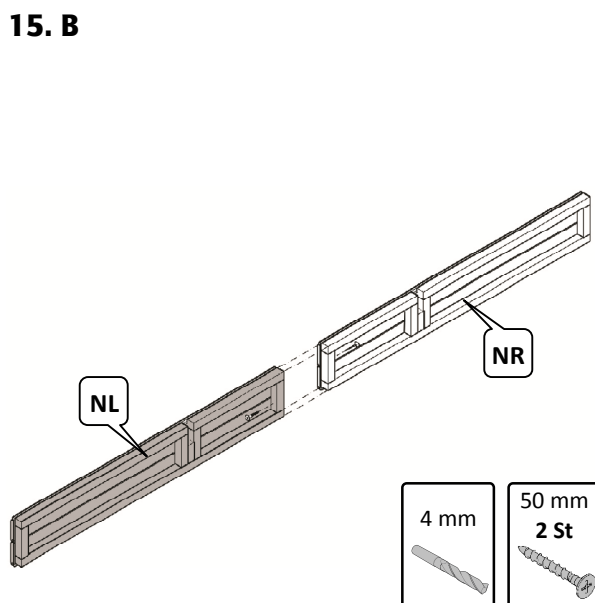

16. B

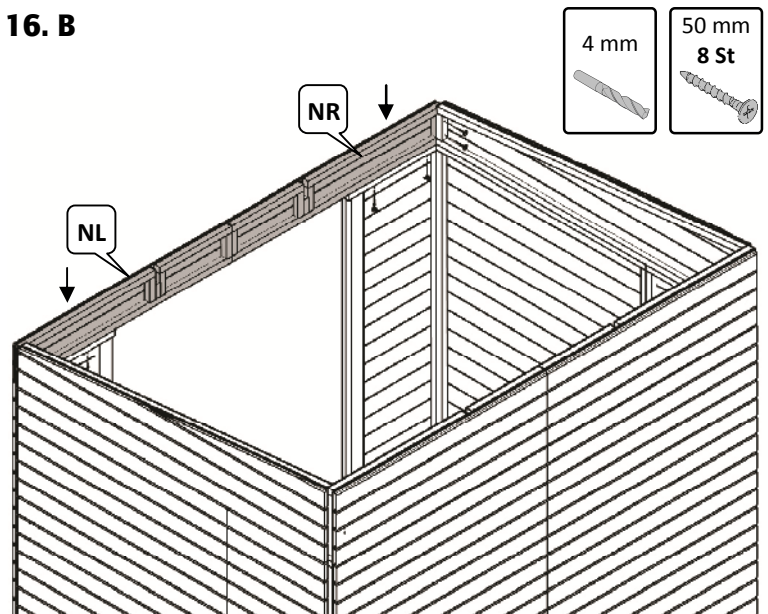

# Timmo 4

16.1 B

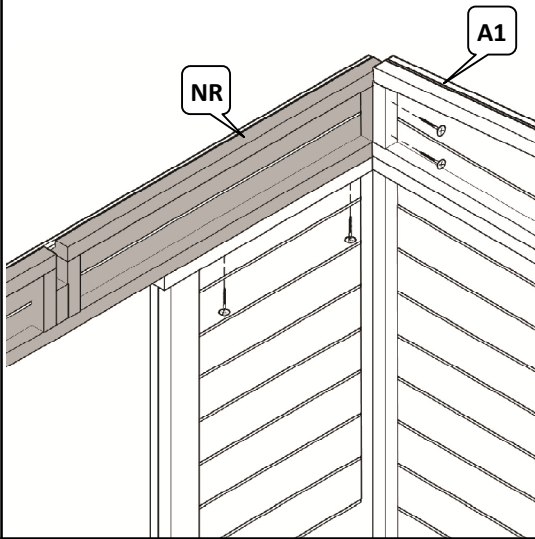

17. B

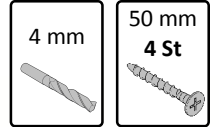
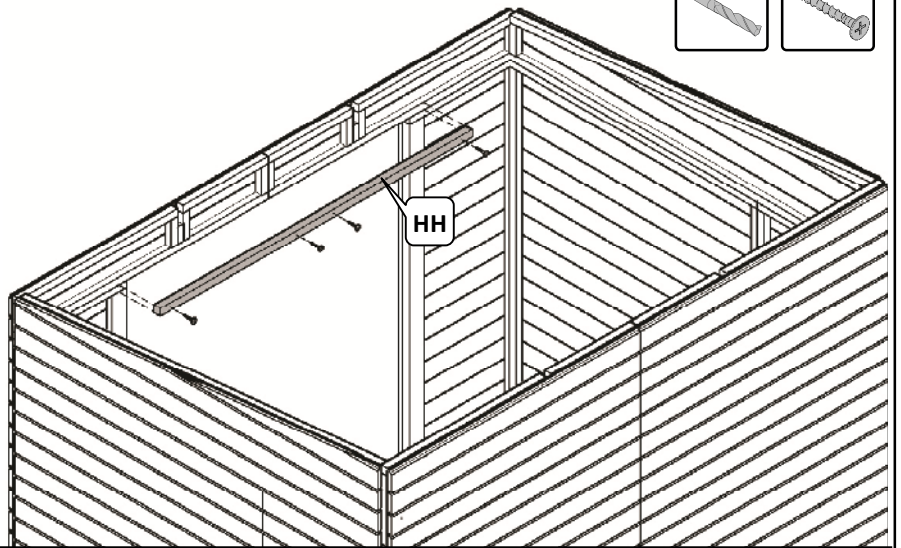

18.

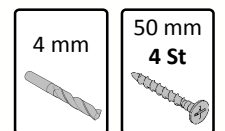
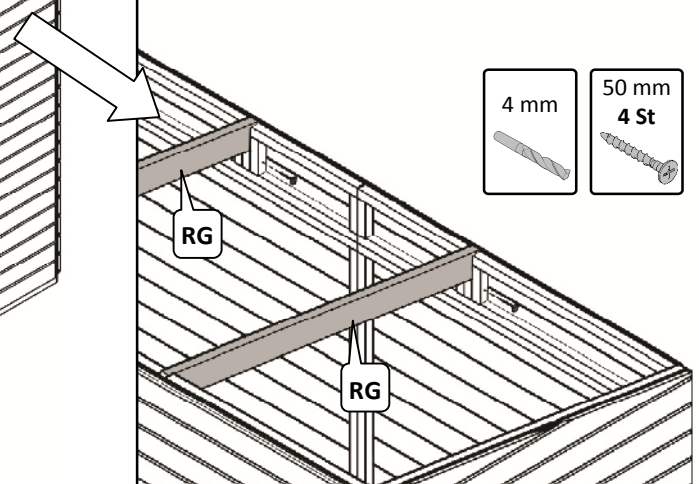
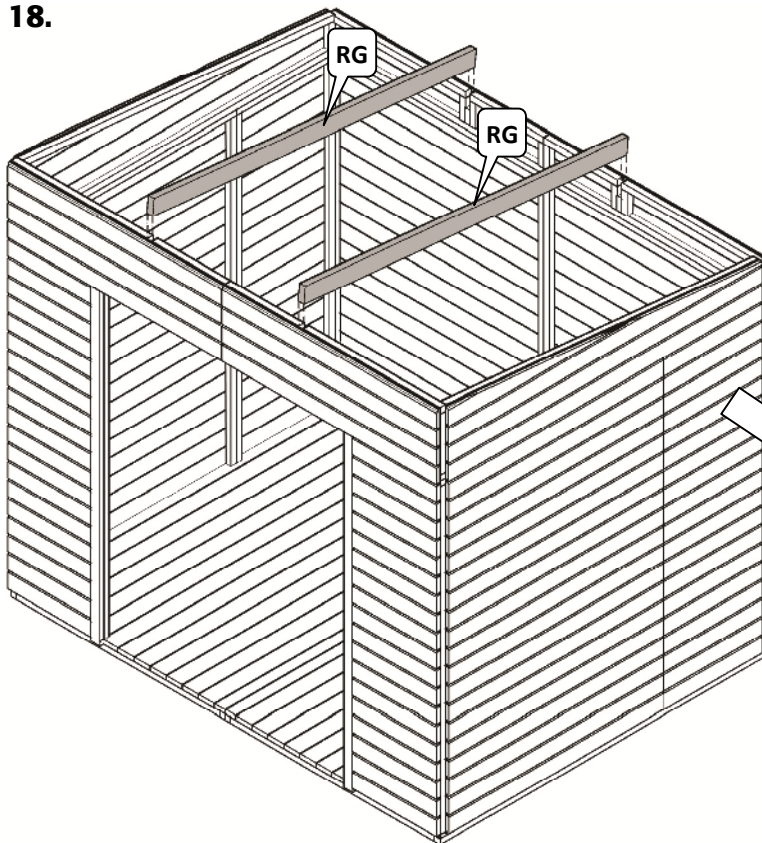

19.

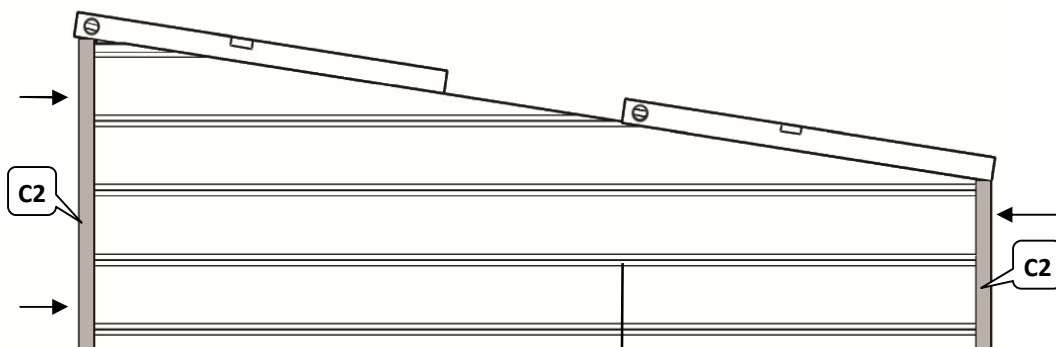



# Timmo 4

20.

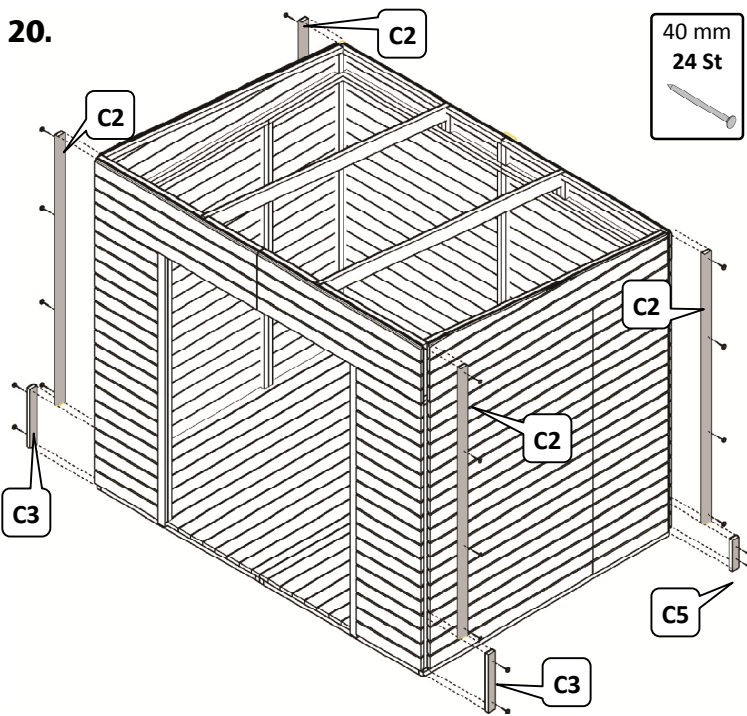

21.

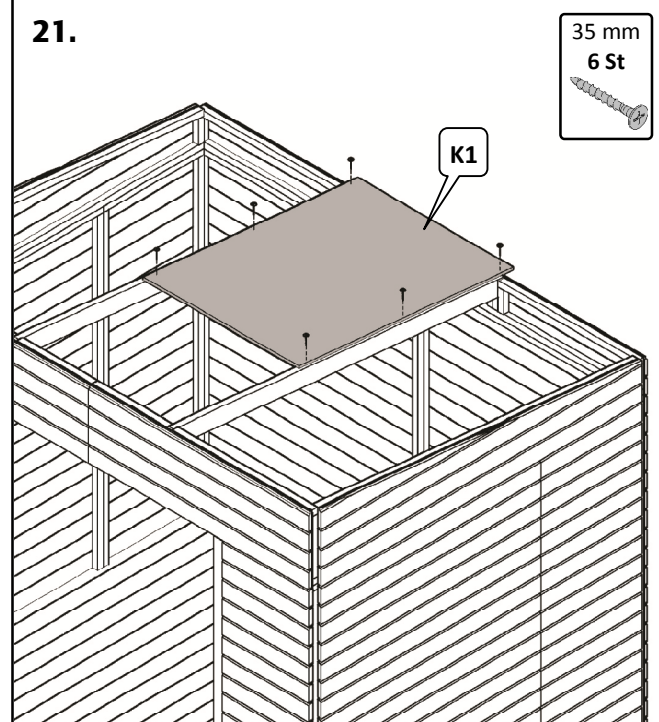

22.

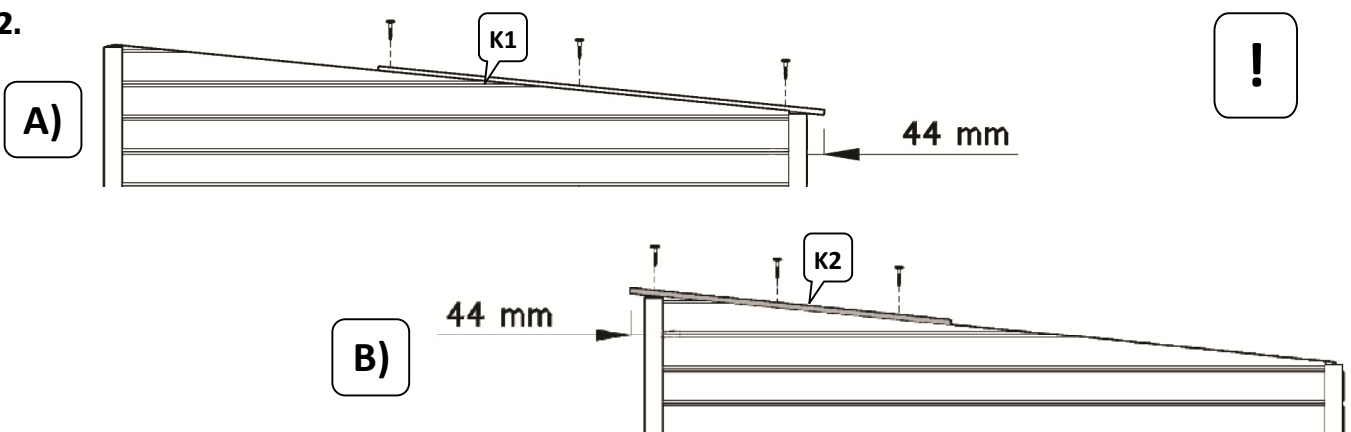

23.

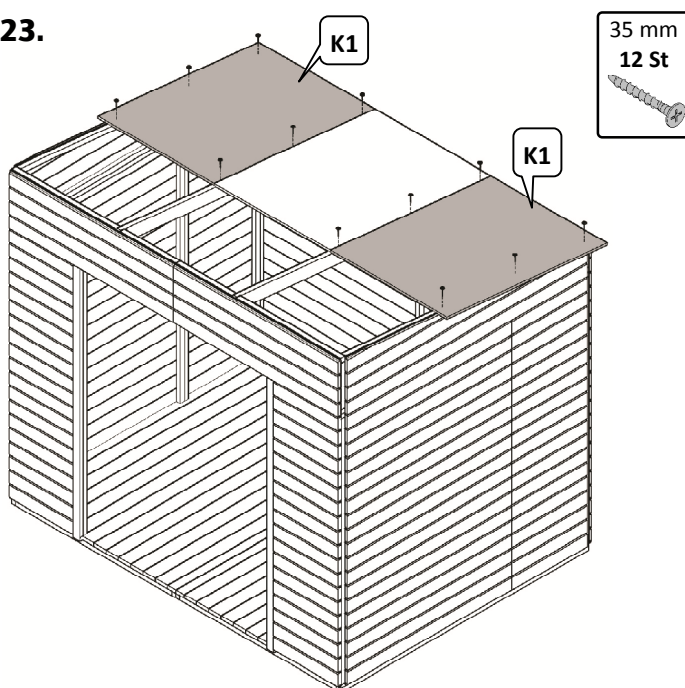

24.

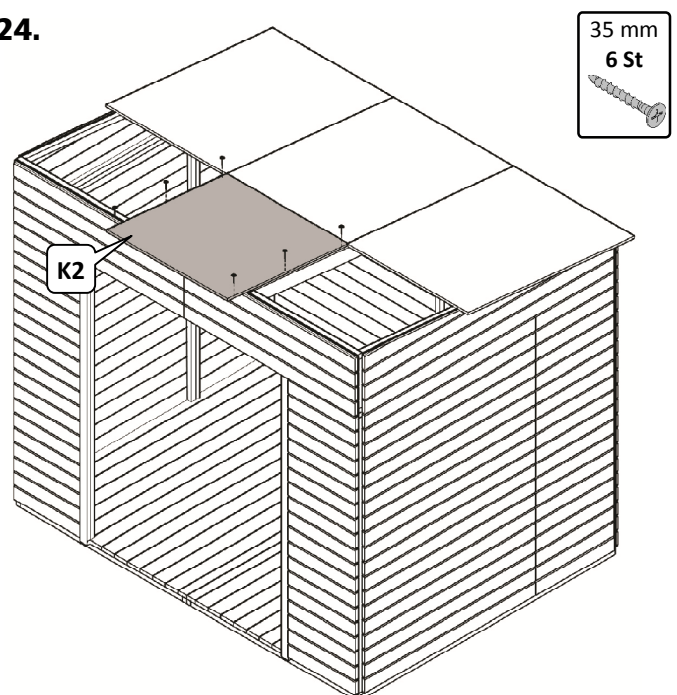

# Timmo 4

25.

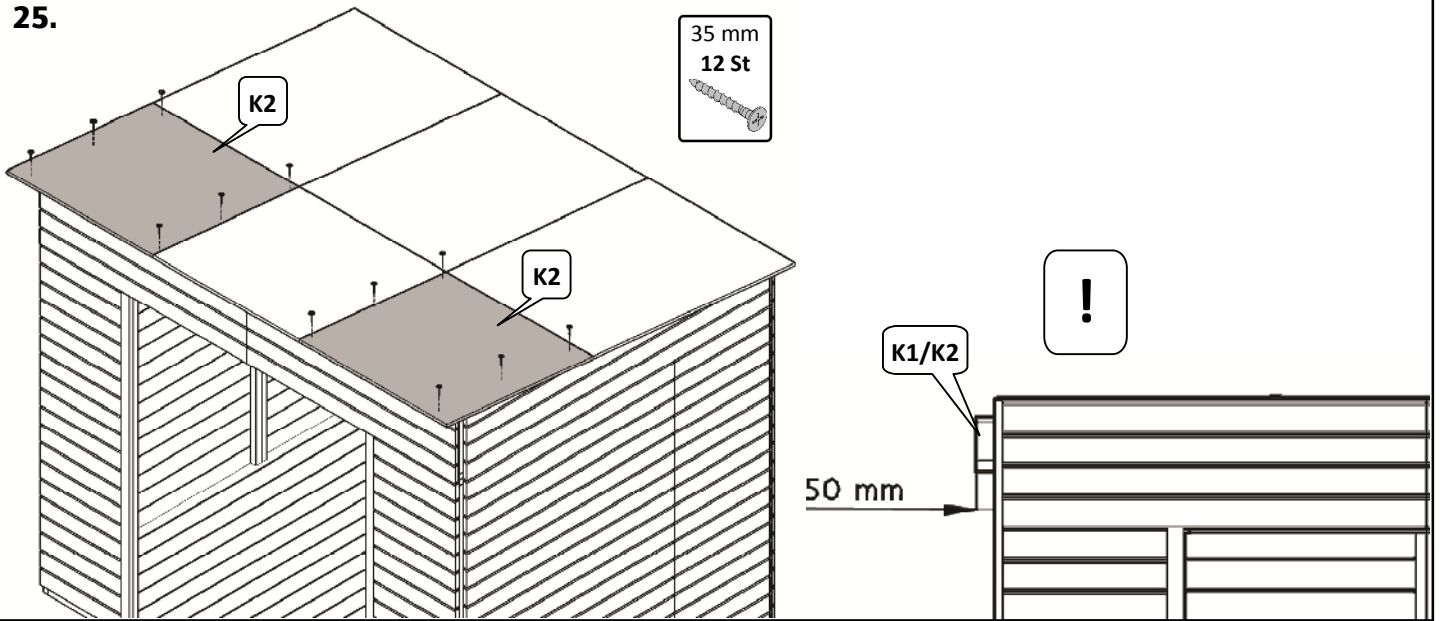

26.

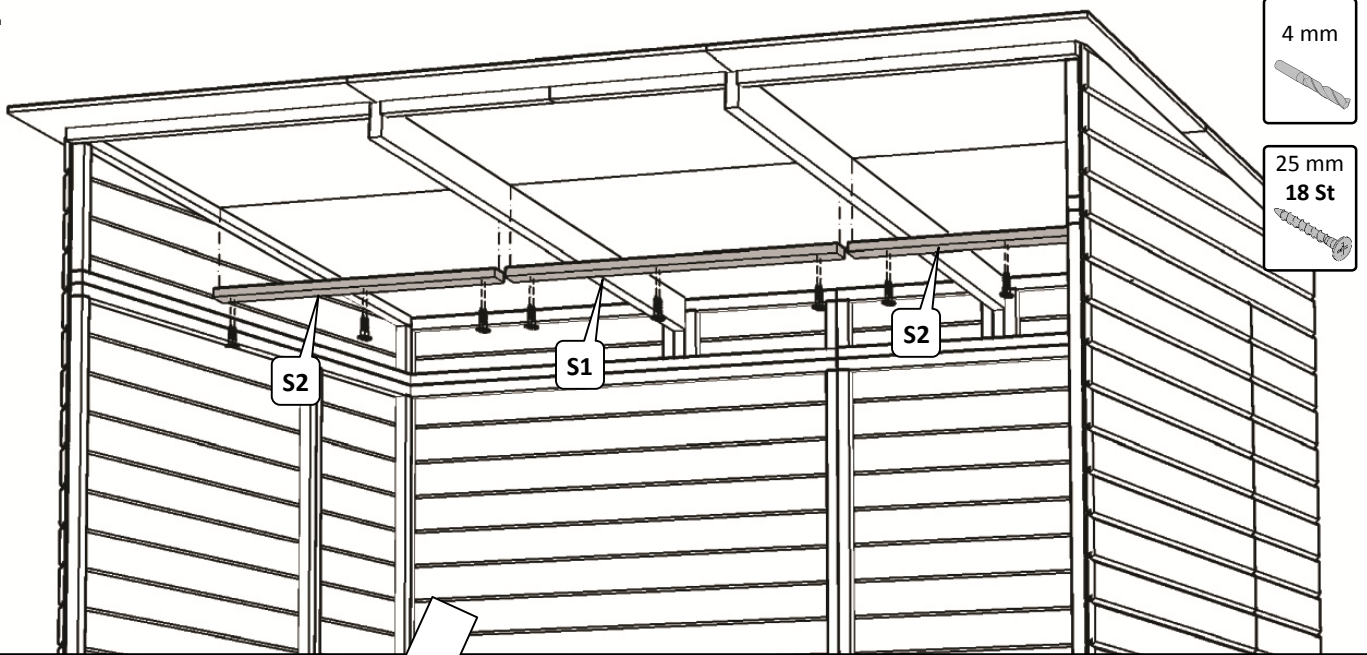

27.

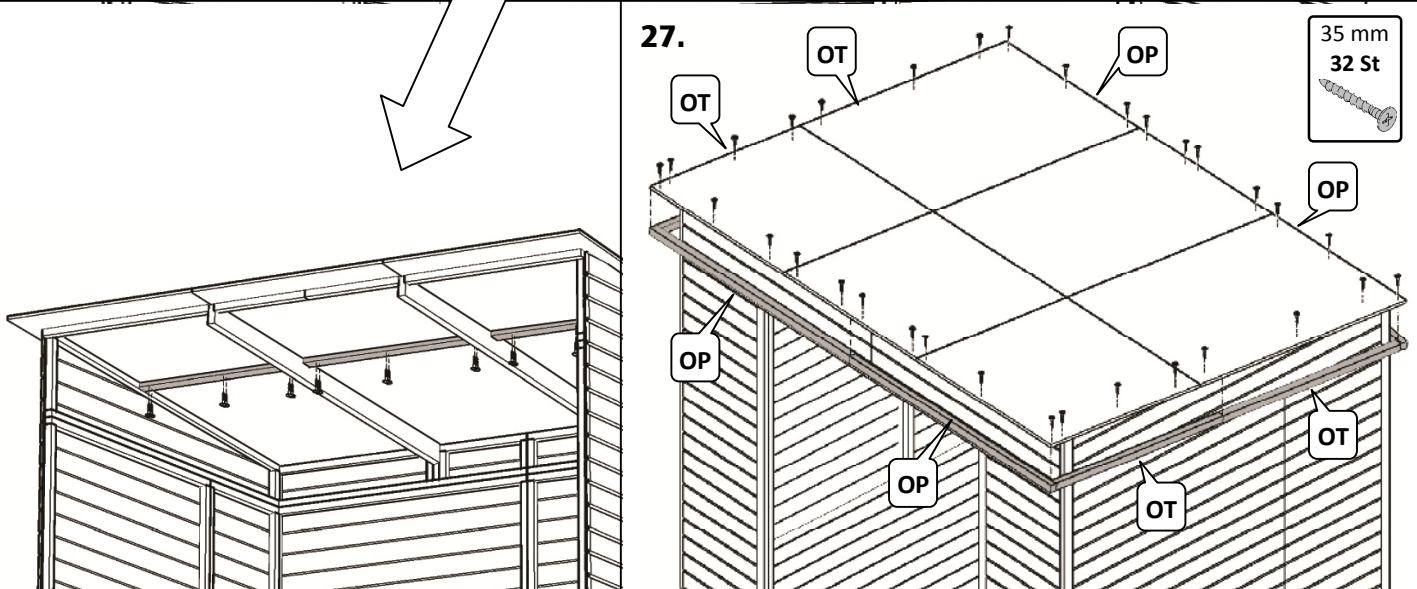



# Timmo 4

27.

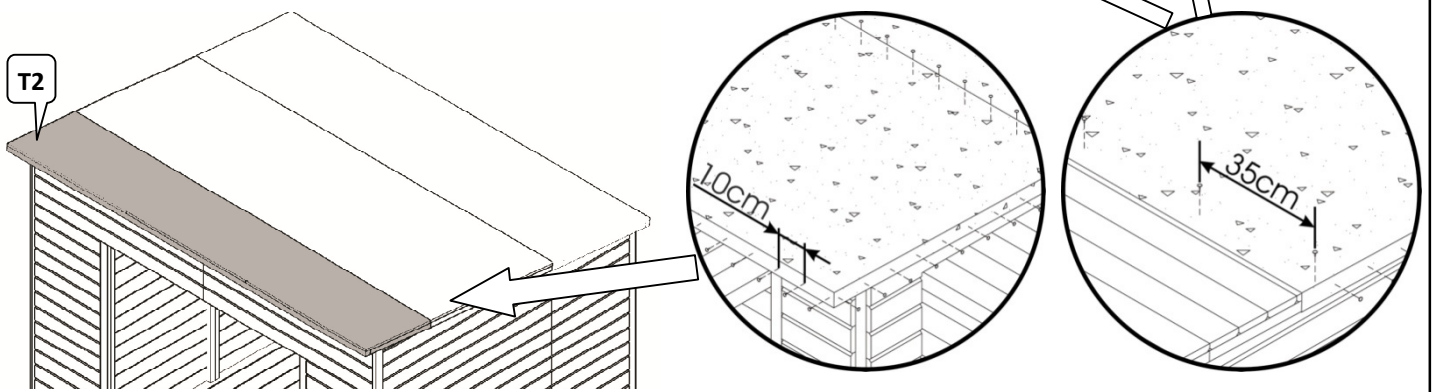
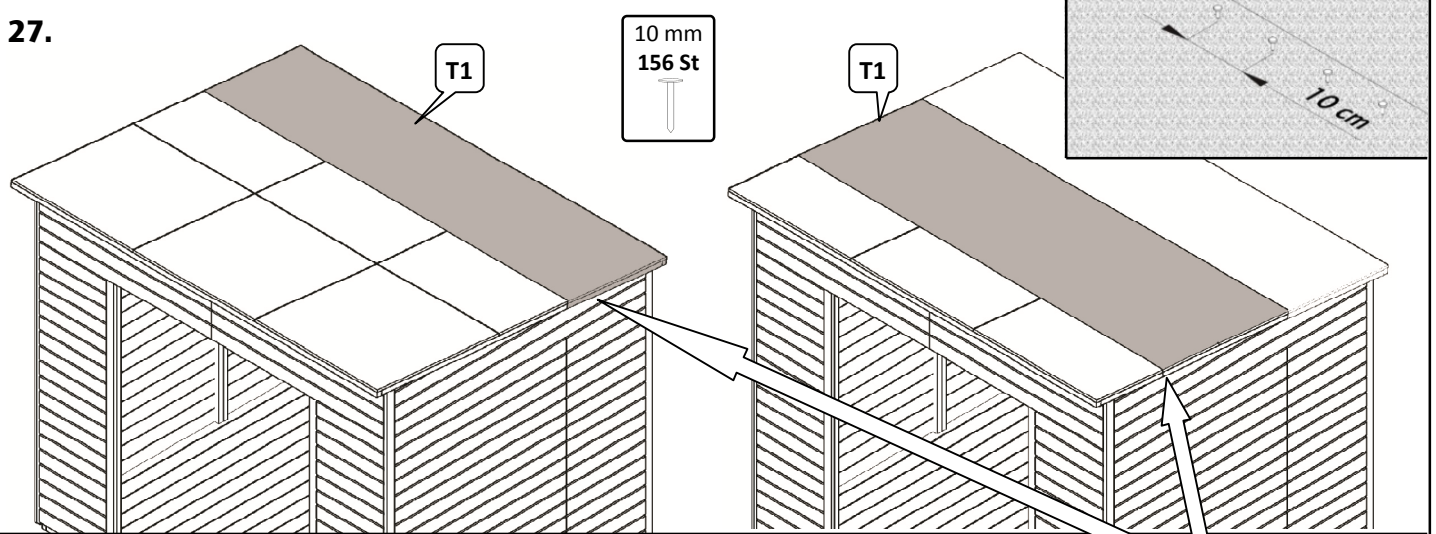

29.

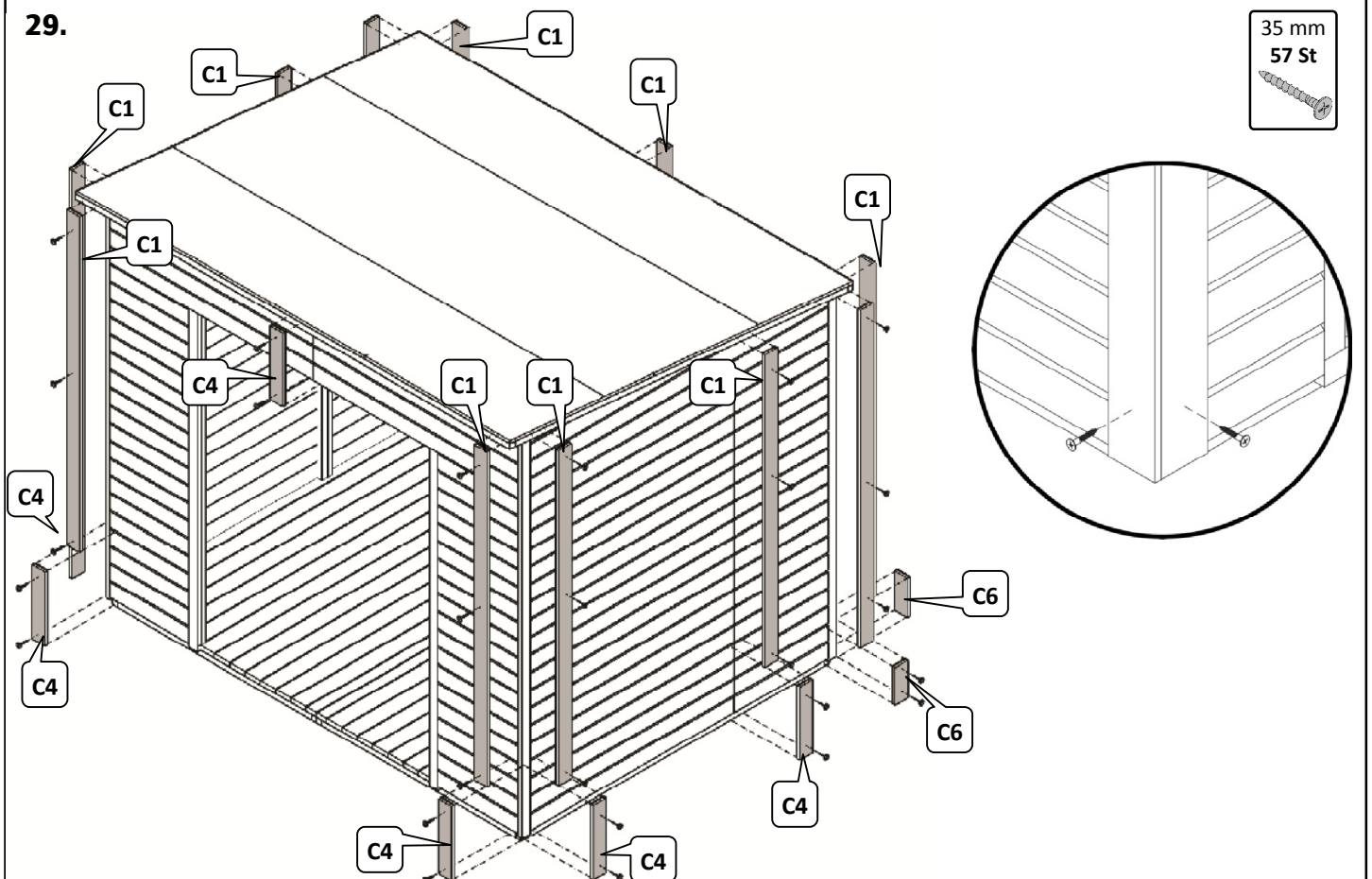

# Timmo 4

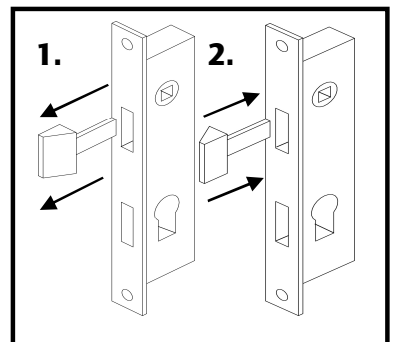
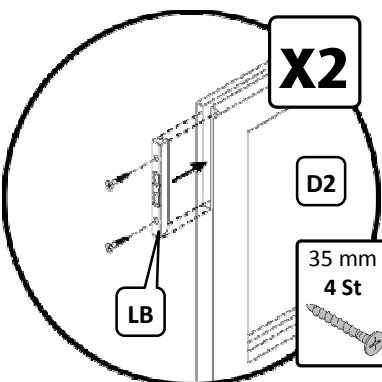
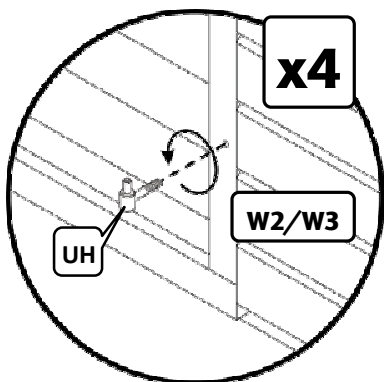
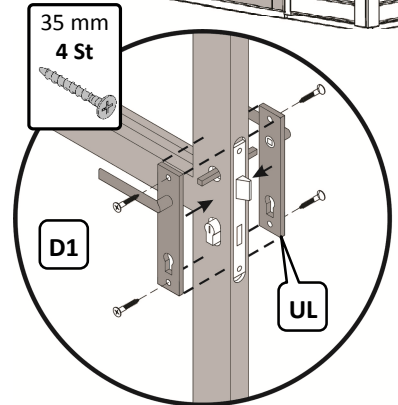
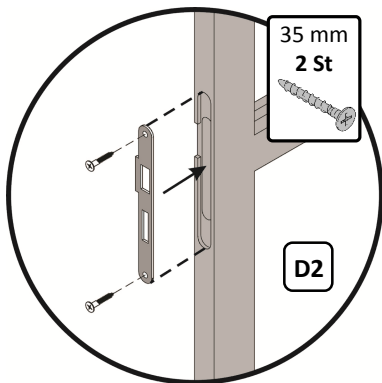
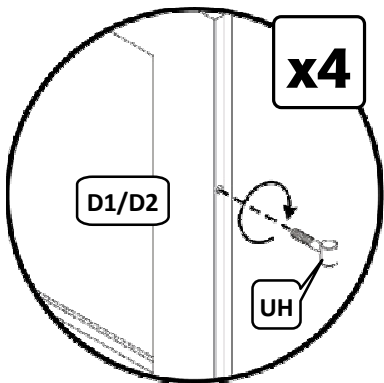
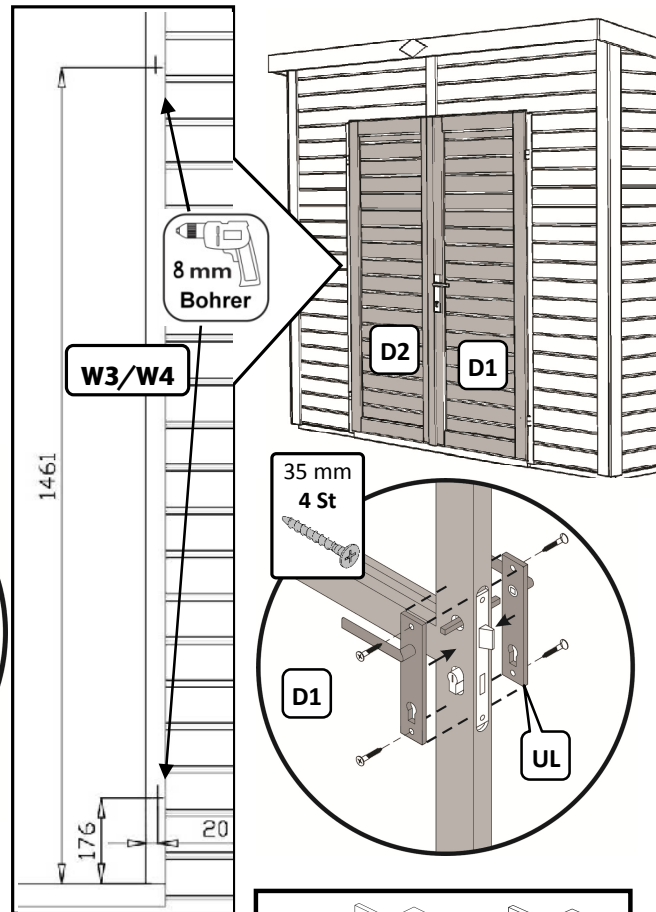
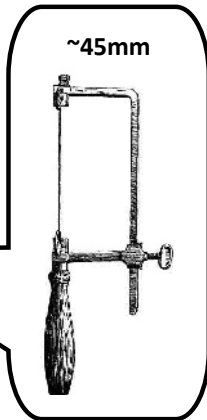
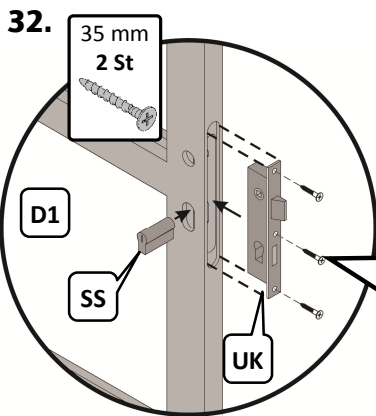
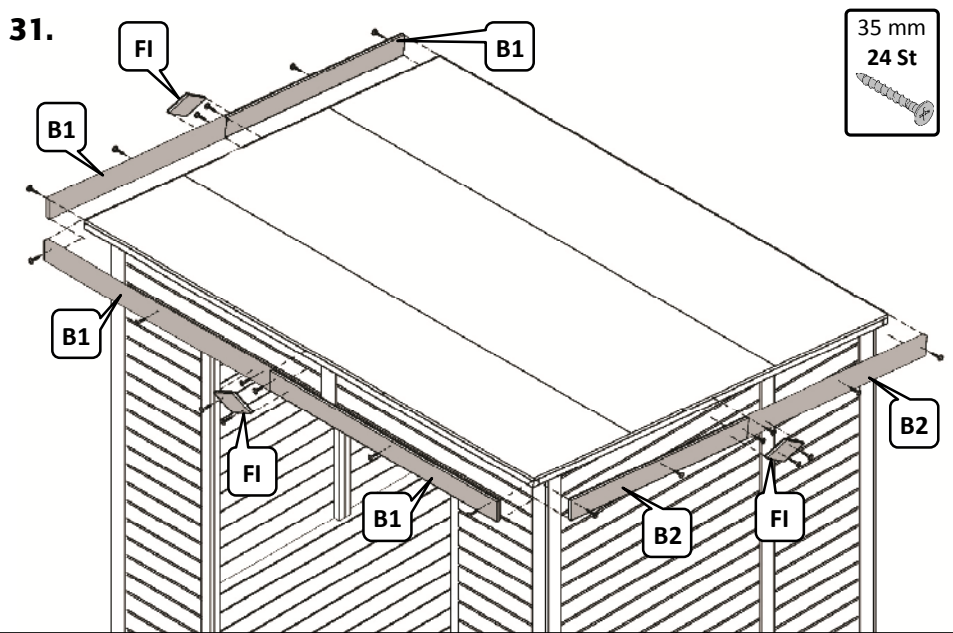
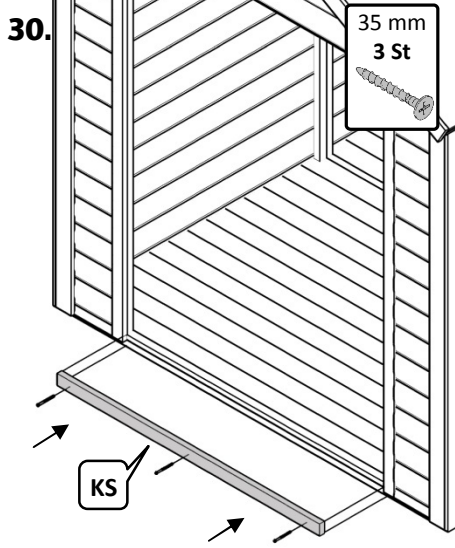



# Timmo 4

33.

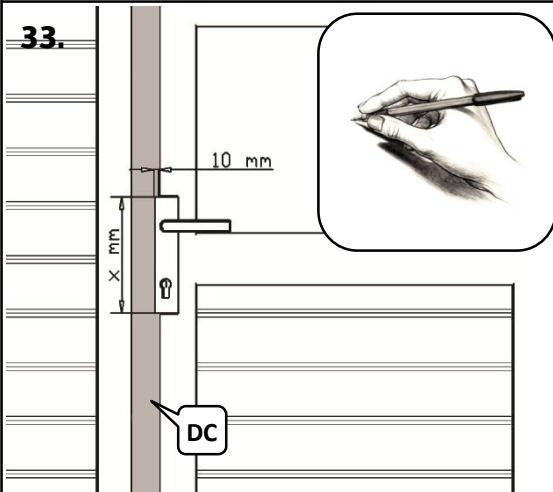

34. A

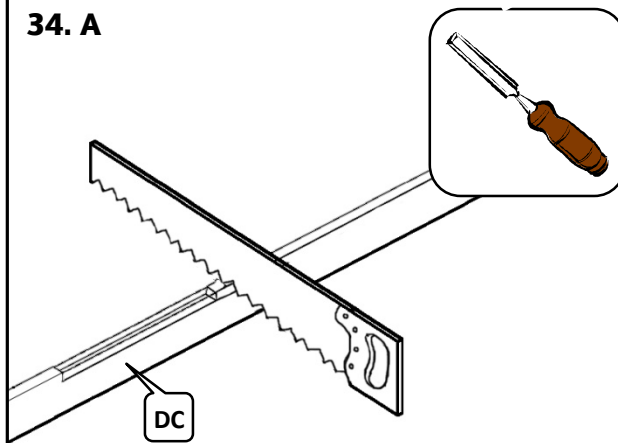

34. B

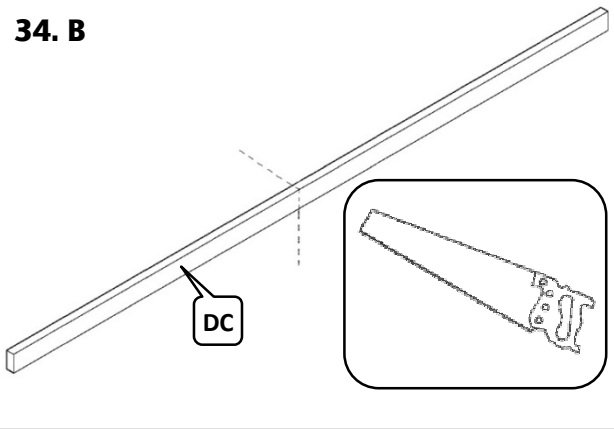

35. A

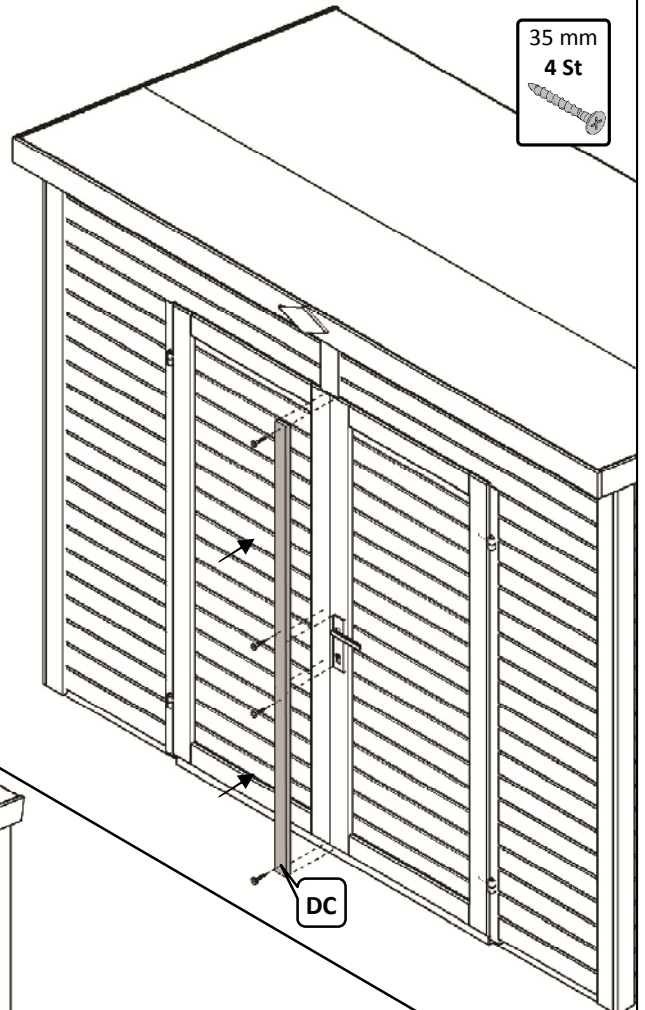

35. B

